

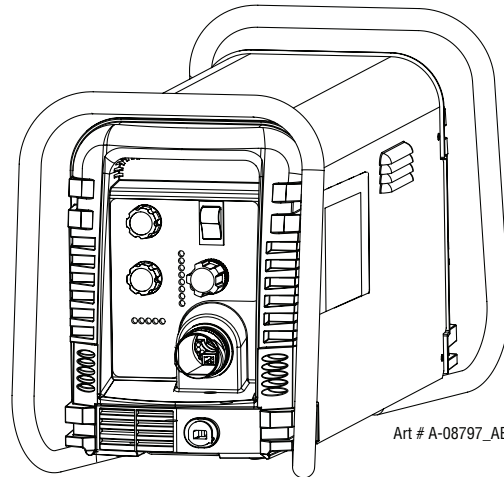

40mm

CUTMASTER™

PLASMA CUTTING SYSTEM



Art # A-08797_AB

Service Manual

Rev. AC

Date: May 29, 2009

Manual # 0-5085

Operating Features:



120
AMP

DC

3
PHASE

380V
400V
415V



WE APPRECIATE YOUR BUSINESS!

Congratulations on your new Thermal Dynamics product. We are proud to have you as our customer and will strive to provide you with the best service and reliability in the industry. This product is backed by our extensive warranty and world-wide service network. To locate your nearest distributor or service agency call 1-800-426-1888, or visit us on the web at www.thermal-dynamics.com.

This Operating Manual has been designed to instruct you on the correct use and operation of your Thermal Dynamics product. Your satisfaction with this product and its safe operation is our ultimate concern. Therefore please take the time to read the entire manual, especially the Safety Precautions. They will help you to avoid potential hazards that may exist when working with this product.

YOU ARE IN GOOD COMPANY!

The Brand of Choice for Contractors and Fabricators Worldwide.

Thermal Dynamics is a Global Brand of manual and automation Plasma Cutting Products for Thermadyne Industries Inc.

We distinguish ourselves from our competition through market-leading, dependable products that have stood the test of time. We pride ourselves on technical innovation, competitive prices, excellent delivery, superior customer service and technical support, together with excellence in sales and marketing expertise.

Above all, we are committed to developing technologically advanced products to achieve a safer working environment within the welding industry.



WARNINGS

Read and understand this entire Manual and your employer's safety practices before installing, operating, or servicing the equipment.

While the information contained in this Manual represents the Manufacturer's best judgement, the Manufacturer assumes no liability for its use.

Plasma Cutting Power Supply
CutMaster™ 40mm
SL100 1Torch™
Service Manual Number 0-5085

Published by:
Thermal Dynamics Corporation
82 Benning Street
West Lebanon, New Hampshire, USA 03784
(603) 298-5711

www.thermal-dynamics.com

Copyright 2008, 2009 by
Thermadyne Corporation

All rights reserved.

Reproduction of this work, in whole or in part, without written permission of the publisher is prohibited.

The publisher does not assume and hereby disclaims any liability to any party for any loss or damage caused by any error or omission in this Manual, whether such error results from negligence, accident, or any other cause.

Printed in the United States of America

Publication Date: December 9, 2008
Revision Date: May 29, 2009

Record the following information for Warranty purposes:

Where Purchased: _____

Purchase Date: _____

Power Supply Serial #: _____

Torch Serial #: _____

This Page Intentionally Blank

TABLE OF CONTENTS

| | |
|--|-------|
| SECTION 1:GENERAL INFORMATION..... | 1-1 |
| 1.01 Notes, Cautions and Warnings | 1-1 |
| 1.02 Important Safety Precautions | 1-1 |
| 1.03 Publications..... | 1-2 |
| 1.04 Note, Attention et Avertissement | 1-3 |
| 1.05 Precautions De Securite Importantes..... | 1-3 |
| 1.06 Documents De Reference..... | 1-5 |
| 1.07 Declaration of Conformity | 1-6 |
| 1.08 Statement of Warranty | 1-7 |
| SECTION 2 SYSTEM:INTRODUCTION | 2-1 |
| 2.01 How To Use This Manual | 2-1 |
| 2.02 Equipment Identification | 2-1 |
| 2.03 Receipt Of Equipment..... | 2-1 |
| 2.04 Power Supply Specifications..... | 2-2 |
| 2.05 Input Wiring Specifications..... | 2-3 |
| 2.06 Power Supply Features..... | 2-4 |
| SECTION 2 TORCH:INTRODUCTION | 2T-1 |
| 2T.01 Scope of Manual..... | 2T-1 |
| 2T.02 General Description | 2T-1 |
| 2T.03 Specifications | 2T-1 |
| 2T.04 Options And Accessories..... | 2T-2 |
| 2T.05 Introduction to Plasma..... | 2T-2 |
| SECTION 3 SYSTEM: INSTALLATION | 3-1 |
| 3.01 Unpacking..... | 3-1 |
| 3.02 Lifting Options..... | 3-1 |
| 3.03 Primary Input Power Connections | 3-2 |
| 3.04 Gas Connections | 3-4 |
| SECTION 3 TORCH: INSTALLATION | 3T-1 |
| 3T.01 Torch Connections | 3T-1 |
| 3T.02 Setting Up Mechanical Torch | 3T-1 |
| SECTION 4 SYSTEM: OPERATION | 4-1 |
| 4.01 Front Panel Controls / Features | 4-1 |
| 4.02 Preparations for Operation..... | 4-2 |
| SECTION 4 TORCH:OPERATION | 4T-1 |
| 4T.01 Torch Parts Selection..... | 4T-1 |
| 4T.02 Cut Quality..... | 4T-2 |
| 4T.03 General Cutting Information..... | 4T-2 |
| 4T.04 Hand Torch Operation..... | 4T-3 |
| 4T.05 Gouging | 4T-7 |
| 4T.06 Mechanized Torch Operation | 4T-8 |
| 4T.07 Parts Selection for SL100Torch Cutting..... | 4T-9 |
| 4T.08 Recommended Cutting Speeds for SL100 Torch With Exposed Tip..... | 4T-10 |
| 4T.09 Recommended Cutting Speeds for SL100Torch With Shielded Tip..... | 4T-15 |

TABLE OF CONTENTS

| | |
|---|-------|
| PATENT INFORMATION | 4T-20 |
| SECTION 5 SYSTEM:SERVICE | 5-1 |
| 5.01 General Maintenance | 5-1 |
| 5.02 Maintenance Schedule | 5-2 |
| 5.03 Common Faults..... | 5-2 |
| 5.04 Fault Indicator | 5-3 |
| 5.05 Basic Troubleshooting Guide | 5-6 |
| 5.06 Circuit Fault Isolation | 5-8 |
| 5.07 Main Input and Internal Power Problems..... | 5-12 |
| 5.08 Pilot Arc Problems | 5-16 |
| 5.09 Main Arc and Controls Problems | 5-19 |
| 5.10 CNC Interface Problems | 5-20 |
| 5.11 Test Procedures..... | 5-20 |
| 5.12 Main PCB Layout & Signals..... | 5-26 |
| 5.13 Capacitor PCB Layout & Signals | 5-30 |
| 5.14 Logic PCB Layout & Signals | 5-32 |
| 5.15 40AMP Logic PCB Layout & Signals | 5-34 |
| 5.16 Right Side Wiring Diagram..... | 5-36 |
| SECTION 5 TORCH:SERVICE | 5T-1 |
| 5T.01 General Maintenance | 5T-1 |
| 5T.02 Inspection and Replacement of Consumable Torch Parts | 5T-2 |
| SECTION 6:PARTS LISTS | 6-1 |
| 6.01 Introduction | 6-1 |
| 6.02 Ordering Information..... | 6-1 |
| 6.03 Power Supply Replacement..... | 6-1 |
| 6.04 Major External Replacement Parts | 6-2 |
| 6.05 Front Panel Replacement Parts | 6-3 |
| 6.06 Left Side Replacement Parts | 6-4 |
| 6.07 Right Side Replacement Parts | 6-5 |
| 6.08 Options and Accessories | 6-6 |
| 6.09 Replacement Parts for Hand Torch | 6-7 |
| 6.10 Replacement Parts - for Machine Torches with Unshielded Leads..... | 6-8 |
| 6.11 Torch Consumable Parts (SL100 SV)..... | 6-10 |
| SECTION 7: REPLACEMENT PROCEDURES | 7-1 |
| 7.01 Scope..... | 7-1 |
| 7.02 Anti-Static Handling Procedures | 7-1 |
| 7.03 Parts Replacement - General Information | 7-1 |
| 7.04 Major External Parts | 7-2 |
| 7.05 Front Panel Parts Replacement..... | 7-3 |
| 7.06 Left Side Internal Parts Replacement..... | 7-4 |
| 7.07 Rear Panel Parts Replacement | 7-6 |
| 7.08 Right Side Internal Parts Replacement..... | 7-8 |

TABLE OF CONTENTS

| | |
|--|-------------------|
| APPENDIX 1: SEQUENCE OF OPERATION(BLOCK DIAGRAM) | A-1 |
| APPENDIX 2: DATA TAG INFORMATION | A-2 |
| APPENDIX 3: TORCH PIN - OUT DIAGRAMS | A-3 |
| APPENDIX 4: TORCH CONNECTION DIAGRAMS..... | A-4 |
| APPENDIX 5: SYSTEM SCHEMATIC, 380-415V UNITS..... | A-6 |
| APPENDIX 6: Publication History..... | A-8 |
| GLOBAL CUSTOMER SERVICE CONTACT INFORMATION | Inside Rear Cover |

TABLE OF CONTENTS

SECTION 1: GENERAL INFORMATION

1.01 Notes, Cautions and Warnings

Throughout this manual, notes, cautions, and warnings are used to highlight important information. These highlights are categorized as follows:

NOTE

An operation, procedure, or background information which requires additional emphasis or is helpful in efficient operation of the system.



CAUTION

A procedure which, if not properly followed, may cause damage to the equipment.



WARNING

A procedure which, if not properly followed, may cause injury to the operator or others in the operating area.

1.02 Important Safety Precautions



WARNINGS

OPERATION AND MAINTENANCE OF PLASMA ARC EQUIPMENT CAN BE DANGEROUS AND HAZARDOUS TO YOUR HEALTH.

Plasma arc cutting produces intense electric and magnetic emissions that may interfere with the proper function of cardiac pacemakers, hearing aids, or other electronic health equipment. Persons who work near plasma arc cutting applications should consult their medical health professional and the manufacturer of the health equipment to determine whether a hazard exists.

To prevent possible injury, read, understand and follow all warnings, safety precautions and instructions before using the equipment. Call 1-603-298-5711 or your local distributor if you have any questions.



GASES AND FUMES

Gases and fumes produced during the plasma cutting process can be dangerous and hazardous to your health.

- Keep all fumes and gases from the breathing area. Keep your head out of the welding fume plume.
- Use an air-supplied respirator if ventilation is not adequate to remove all fumes and gases.

- The kinds of fumes and gases from the plasma arc depend on the kind of metal being used, coatings on the metal, and the differing processes. You must be very careful when cutting or welding any metals which may contain one or more of the following:

| | | |
|-----------|-----------|----------|
| Antimony | Chromium | Mercury |
| Arsenic | Cobalt | Nickel |
| Barium | Copper | Selenium |
| Beryllium | Lead | Silver |
| Cadmium | Manganese | Vanadium |

- Always read the Material Safety Data Sheets (MSDS) that should be supplied with the material you are using. These MSDSs will give you the information regarding the kind and amount of fumes and gases that may be dangerous to your health.
- For information on how to test for fumes and gases in your workplace, refer to item 1 in Subsection 1.03, Publications in this manual.
- Use special equipment, such as water or down draft cutting tables, to capture fumes and gases.
- Do not use the plasma torch in an area where combustible or explosive gases or materials are located.
- Phosgene, a toxic gas, is generated from the vapors of chlorinated solvents and cleansers. Remove all sources of these vapors.
- This product, when used for welding or cutting, produces fumes or gases which contain chemicals known to the State of California to cause birth defects and, in some cases, cancer. (California Health & Safety Code Sec. 25249.5 et seq.)



ELECTRIC SHOCK

Electric Shock can injure or kill. The plasma arc process uses and produces high voltage electrical energy. This electric energy can cause severe or fatal shock to the operator or others in the workplace.

- Never touch any parts that are electrically “live” or “hot.”
- Wear dry gloves and clothing. Insulate yourself from the work piece or other parts of the welding circuit.
- Repair or replace all worn or damaged parts.
- Extra care must be taken when the workplace is moist or damp.
- Install and maintain equipment according to NEC code, refer to item 9 in Subsection 1.03, Publications.
- Disconnect power source before performing any service or repairs.
- Read and follow all the instructions in the Operating Manual.



FIRE AND EXPLOSION

Fire and explosion can be caused by hot slag, sparks, or the plasma arc.

- Be sure there is no combustible or flammable material in the workplace. Any material that cannot be removed must be protected.
- Ventilate all flammable or explosive vapors from the workplace.

CUTMASTER 40mm

- Do not cut or weld on containers that may have held combustibles.
- Provide a fire watch when working in an area where fire hazards may exist.
- Hydrogen gas may be formed and trapped under aluminum workpieces when they are cut underwater or while using a water table. **DO NOT** cut aluminum alloys underwater or on a water table unless the hydrogen gas can be eliminated or dissipated. Trapped hydrogen gas that is ignited will cause an explosion.



NOISE

Noise can cause permanent hearing loss. Plasma arc processes can cause noise levels to exceed safe limits. You must protect your ears from loud noise to prevent permanent loss of hearing.

- To protect your hearing from loud noise, wear protective ear plugs and/or ear muffs. Protect others in the workplace.
- Noise levels should be measured to be sure the decibels (sound) do not exceed safe levels.
- For information on how to test for noise, see item 1 in Subsection 1.03, Publications, in this manual.



PLASMA ARC RAYS

Plasma Arc Rays can injure your eyes and burn your skin. The plasma arc process produces very bright ultra violet and infra red light. These arc rays will damage your eyes and burn your skin if you are not properly protected.

- To protect your eyes, always wear a welding helmet or shield. Also always wear safety glasses with side shields, goggles or other protective eye wear.
- Wear welding gloves and suitable clothing to protect your skin from the arc rays and sparks.
- Keep helmet and safety glasses in good condition. Replace lenses when cracked, chipped or dirty.
- Protect others in the work area from the arc rays. Use protective booths, screens or shields.
- Use the shade of lens as suggested in the following per ANSI/ASC Z49.1:

| Arc Current | Minimum Protective Shade No. | Suggested Shade No. |
|----------------|------------------------------|---------------------|
| Less Than 300* | 8 | 9 |
| 300 - 400* | 9 | 12 |
| 400 - 800* | 10 | 14 |

* These values apply where the actual arc is clearly seen. Experience has shown that lighter filters may be used when the arc is hidden by the workpiece.



LEAD WARNING

This product contains chemicals, including lead, or otherwise produces chemicals known to the State of California to cause cancer, birth defects and other reproductive harm. **Wash hands after handling.** (California Health & Safety Code § 25249.5 et seq.)

1.03 Publications

Refer to the following standards or their latest revisions for more information:

1. OSHA, SAFETY AND HEALTH STANDARDS, 29CFR 1910, obtainable from the Superintendent of Documents, U.S. Government Printing Office, Washington, D.C. 20402
2. ANSI Standard Z49.1, SAFETY IN WELDING AND CUTTING, obtainable from the American Welding Society, 550 N.W. LeJeune Rd, Miami, FL 33126
3. NIOSH, SAFETY AND HEALTH IN ARC WELDING AND GAS WELDING AND CUTTING, obtainable from the Superintendent of Documents, U.S. Government Printing Office, Washington, D.C. 20402
4. ANSI Standard Z87.1, SAFE PRACTICES FOR OCCUPATION AND EDUCATIONAL EYE AND FACE PROTECTION, obtainable from American National Standards Institute, 1430 Broadway, New York, NY 10018
5. ANSI Standard Z41.1, STANDARD FOR MEN'S SAFETY-TOE FOOTWEAR, obtainable from the American National Standards Institute, 1430 Broadway, New York, NY 10018
6. ANSI Standard Z49.2, FIRE PREVENTION IN THE USE OF CUTTING AND WELDING PROCESSES, obtainable from American National Standards Institute, 1430 Broadway, New York, NY 10018
7. AWS Standard A6.0, WELDING AND CUTTING CONTAINERS WHICH HAVE HELD COMBUSTIBLES, obtainable from American Welding Society, 550 N.W. LeJeune Rd, Miami, FL 33126
8. NFPA Standard 51, OXYGEN-FUEL GAS SYSTEMS FOR WELDING, CUTTING AND ALLIED PROCESSES, obtainable from the National Fire Protection Association, Batterymarch Park, Quincy, MA 02269
9. NFPA Standard 70, NATIONAL ELECTRICAL CODE, obtainable from the National Fire Protection Association, Batterymarch Park, Quincy, MA 02269
10. NFPA Standard 51B, CUTTING AND WELDING PROCESSES, obtainable from the National Fire Protection Association, Batterymarch Park, Quincy, MA 02269
11. CGA Pamphlet P-1, SAFE HANDLING OF COMPRESSED GASES IN CYLINDERS, obtainable from the Compressed Gas Association, 1235 Jefferson Davis Highway, Suite 501, Arlington, VA 22202
12. CSA Standard W117.2, CODE FOR SAFETY IN WELDING AND CUTTING, obtainable from the Canadian Standards Association, Standards Sales, 178 Rexdale Boulevard, Rexdale, Ontario, Canada M9W 1R3
13. NWSA booklet, WELDING SAFETY BIBLIOGRAPHY obtainable from the National Welding Supply Association, 1900 Arch Street, Philadelphia, PA 19103

14. American Welding Society Standard AWSF4.1, RECOMMENDED SAFE PRACTICES FOR THE PREPARATION FOR WELDING AND CUTTING OF CONTAINERS AND PIPING THAT HAVE HELD HAZARDOUS SUBSTANCES, obtainable from the American Welding Society, 550 N.W. LeJeune Rd, Miami, FL 33126

15. ANSI Standard Z88.2, PRACTICE FOR RESPIRATORY PROTECTION, obtainable from American National Standards Institute, 1430 Broadway, New York, NY 10018

1.04 Note, Attention et Avertissement

Dans ce manuel, les mots “note,” “attention,” et “avertissement” sont utilisés pour mettre en relief des informations à caractère important. Ces mises en relief sont classifiées comme suit :

NOTE

Toute opération, procédure ou renseignement général sur lequel il importe d’insister davantage ou qui contribue à l’efficacité de fonctionnement du système.



ATTENTION

Toute procédure pouvant résulter l’endommagement du matériel en cas de non-respect de la procédure en question.



AVERTISSEMENT

Toute procédure pouvant provoquer des blessures de l’opérateur ou des autres personnes se trouvant dans la zone de travail en cas de non-respect de la procédure en question.

1.05 Precautions De Securite Importantes



AVERTISSEMENTS

L’OPÉRATION ET LA MAINTENANCE DU MATÉRIEL DE SOUDAGE À L’ARC AU JET DE PLASMA PEUVENT PRÉSENTER DES RISQUES ET DES DANGERS DE SANTÉ.

Coupant à l’arc au jet de plasma produit de l’énergie électrique haute tension et des émissions magnétique qui peuvent interférer la fonction propre d’un “pacemaker” cardiaque, les appareils auditif, ou autre matériel de santé électronique. Ceux qui travail près d’une application à l’arc au jet de plasma devrait consulter leur membre professionnel de médication et le manufacturier de matériel de santé pour déterminer s’il existe des risques de santé.

Il faut communiquer aux opérateurs et au personnel TOUS les dangers possibles. Afin d’éviter les blessures possibles, lisez, comprenez et suivez tous les avertissements, toutes les précautions de sécurité et toutes les consignes avant d’utiliser le matériel. Composez le + 603-298-5711 ou votre distributeur local si vous avez des questions.



FUMÉE et GAZ

La fumée et les gaz produits par le procédé de jet de plasma peuvent présenter des risques et des dangers de santé.

- Eloignez toute fumée et gaz de votre zone de respiration. Gardez votre tête hors de la plume de fumée provenant du chalumeau.
- Utilisez un appareil respiratoire à alimentation en air si l’aération fournie ne permet pas d’éliminer la fumée et les gaz.
- Les sortes de gaz et de fumée provenant de l’arc de plasma dépendent du genre de métal utilisé, des revêtements se trouvant sur le métal et des différents procédés. Vous devez prendre soin lorsque vous coupez ou soudez tout métal pouvant contenir un ou plusieurs des éléments suivants:

| | | |
|-----------|-----------|----------|
| antimoine | cadmium | mercure |
| argent | chrome | nickel |
| arsenic | cobalt | plomb |
| baryum | cuivre | sélénium |
| béryllium | manganèse | vanadium |

- Lisez toujours les fiches de données sur la sécurité des matières (sigle américain “MSDS”); celles-ci devraient être fournies avec le matériel que vous utilisez. Les MSDS contiennent des renseignements quant à la quantité et la nature de la fumée et des gaz pouvant poser des dangers de santé.
- Pour des informations sur la manière de tester la fumée et les gaz de votre lieu de travail, consultez l’article 1 et les documents cités à la page 5.
- Utilisez un équipement spécial tel que des tables de coupe à débit d’eau ou à courant descendant pour capter la fumée et les gaz.
- N’utilisez pas le chalumeau au jet de plasma dans une zone où se trouvent des matières ou des gaz combustibles ou explosifs.
- Le phosgène, un gaz toxique, est généré par la fumée provenant des solvants et des produits de nettoyage chlorés. Éliminez toute source de telle fumée.
- Ce produit, dans le procédé de soudage et de coupe, produit de la fumée ou des gaz pouvant contenir des éléments reconnu dans L’état de la Californie, qui peuvent causer des défauts de naissance et le cancer. (La sécurité de santé en Californie et la code sécurité Sec. 25249.5 et seq.)



CHOC ELECTRIQUE

Les chocs électriques peuvent blesser ou même tuer. Le procédé au jet de plasma requiert et produit de l’énergie électrique haute tension. Cette énergie électrique peut produire des chocs graves, voire mortels, pour l’opérateur et les autres personnes sur le lieu de travail.

- Ne touchez jamais une pièce “sous tension” ou “vive”; portez des gants et des vêtements secs. Isolez-vous de la pièce de travail ou des autres parties du circuit de soudage.
- Réparez ou remplacez toute pièce usée ou endommagée.
- Prenez des soins particuliers lorsque la zone de travail est humide ou moite.

CUTMASTER 40mm

- Montez et maintenez le matériel conformément au Code électrique national des Etats-Unis. (Voir la page 5, article 9.)
- Débranchez l'alimentation électrique avant tout travail d'entretien ou de réparation.
- Lisez et respectez toutes les consignes du Manuel de consignes.



INCENDIE ET EXPLOSION

Les incendies et les explosions peuvent résulter des scories chaudes, des étincelles ou de l'arc de plasma. Le procédé à l'arc de plasma produit du métal, des étincelles, des scories chaudes pouvant mettre le feu aux matières combustibles ou provoquer l'explosion de fumées inflammables.

- Soyez certain qu'aucune matière combustible ou inflammable ne se trouve sur le lieu de travail. Protégez toute telle matière qu'il est impossible de retirer de la zone de travail.
- Procurez une bonne aération de toutes les fumées inflammables ou explosives.
- Ne coupez pas et ne soudez pas les conteneurs ayant pu renfermer des matières combustibles.
- Prévoyez une veille d'incendie lors de tout travail dans une zone présentant des dangers d'incendie.
- Le gas hydrogène peut se former ou s'accumuler sous les pièces de travail en aluminium lorsqu'elles sont coupées sous l'eau ou sur une table d'eau. NE PAS couper les alliages en aluminium sous l'eau ou sur une table d'eau à moins que le gas hydrogène peut s'échapper ou se dissiper. Le gas hydrogène accumulé explosera si enflammé.



RAYONS D'ARC DE PLASMA

Les rayons provenant de l'arc de plasma peuvent blesser vos yeux et brûler votre peau. Le procédé à l'arc de plasma produit une lumière infra-rouge et des rayons ultra-violets très forts. Ces rayons d'arc nuiront à vos yeux et brûleront votre peau si vous ne vous protégez pas correctement.

- Pour protéger vos yeux, portez toujours un casque ou un écran de soudeur. Portez toujours des lunettes de sécurité munies de parois latérales ou des lunettes de protection ou une autre sorte de protection oculaire.
- Portez des gants de soudeur et un vêtement protecteur approprié pour protéger votre peau contre les étincelles et les rayons de l'arc.
- Maintenez votre casque et vos lunettes de protection en bon état. Remplacez toute lentille sale ou comportant fissure ou rognure.
- Protégez les autres personnes se trouvant sur la zone de travail contre les rayons de l'arc en fournissant des cabines ou des écrans de protection.

- Utilisez la nuance de lentille qui est suggérée dans la recommandation qui suivent ANSI/ASC Z49.1:

| Courant Arc | Nuance Minimum Protective Numéro | Nuance Suggestée Numéro |
|---------------|----------------------------------|-------------------------|
| Moins de 300* | 8 | 9 |
| 300 - 400* | 9 | 12 |
| 400 - 800* | 10 | 14 |

* Ces valeurs s'appliquent ou l'arc actuel est observé clairement. L'expérience a démontré que les filtres moins foncés peuvent être utilisés quand l'arc est caché par moiceau de travail.



BRUIT

Le bruit peut provoquer une perte permanente de l'ouïe. Les procédés de soudage à l'arc de plasma peuvent provoquer des niveaux sonores supérieurs aux limites normalement acceptables. Vous devez vous protéger les oreilles contre les bruits forts afin d'éviter une perte permanente de l'ouïe.

- Pour protéger votre ouïe contre les bruits forts, portez des tampons protecteurs et/ou des protections auriculaires. Protégez également les autres personnes se trouvant sur le lieu de travail.
- Il faut mesurer les niveaux sonores afin d'assurer que les décibels (le bruit) ne dépassent pas les niveaux sûrs.
- Pour des renseignements sur la manière de tester le bruit, consultez l'article 1, page 5.



PLOMB AVERTISSEMENT

Ce produit contient des produits chimiques, comme le plomb, ou engendre des produits chimiques, reconnus par l'état de Californie comme pouvant être à l'origine de cancer, de malformations fœtales ou d'autres problèmes de reproduction. **Il faut se laver les mains après toute manipulation.** (Code de Californie de la sécurité et santé, paragraphe 25249.5 et suivants)

1.06 Documents De Reference

Consultez les normes suivantes ou les révisions les plus récentes ayant été faites à celles-ci pour de plus amples renseignements :

1. OSHA, NORMES DE SÉCURITÉ DU TRAVAIL ET DE PROTECTION DE LA SANTÉ, 29CFR 1910, disponible auprès du Superintendent of Documents, U.S. Government Printing Office, Washington, D.C. 20402
2. Norme ANSI Z49.1, LA SÉCURITÉ DES OPÉRATIONS DE COUPE ET DE SOUDAGE, disponible auprès de la Société Américaine de Soudage (American Welding Society), 550 N.W. LeJeune Rd., Miami, FL 33126
3. NIOSH, LA SÉCURITÉ ET LA SANTÉ LORS DES OPÉRATIONS DE COUPE ET DE SOUDAGE À L'ARC ET AU GAZ, disponible auprès du Superintendent of Documents, U.S. Government Printing Office, Washington, D.C. 20402
4. Norme ANSI Z87.1, PRATIQUES SURES POUR LA PROTECTION DES YEUX ET DU VISAGE AU TRAVAIL ET DANS LES ECOLES, disponible de l'Institut Américain des Normes Nationales (American National Standards Institute), 1430 Broadway, New York, NY 10018
5. Norme ANSI Z41.1, NORMES POUR LES CHAUSSURES PROTECTRICES, disponible auprès de l'American National Standards Institute, 1430 Broadway, New York, NY 10018
6. Norme ANSI Z49.2, PRÉVENTION DES INCENDIES LORS DE L'EMPLOI DE PROCÉDÉS DE COUPE ET DE SOUDAGE, disponible auprès de l'American National Standards Institute, 1430 Broadway, New York, NY 10018
7. Norme A6.0 de l'Association Américaine du Soudage (AWS), LE SOUDAGE ET LA COUPE DE CONTENEURS AYANT RENFERMÉ DES PRODUITS COMBUSTIBLES, disponible auprès de la American Welding Society, 550 N.W. LeJeune Rd., Miami, FL 33126
8. Norme 51 de l'Association Américaine pour la Protection contre les Incendies (NFPA), LES SYSTEMES À GAZ AVEC ALIMENTATION EN OXYGENE POUR LE SOUDAGE, LA COUPE ET LES PROCÉDÉS ASSOCIÉS, disponible auprès de la National Fire Protection Association, Batterymarch Park, Quincy, MA 02269
9. Norme 70 de la NFPA, CODE ELECTRIQUE NATIONAL, disponible auprès de la National Fire Protection Association, Batterymarch Park, Quincy, MA 02269
10. Norme 51B de la NFPA, LES PROCÉDÉS DE COUPE ET DE SOUDAGE, disponible auprès de la National Fire Protection Association, Batterymarch Park, Quincy, MA 02269
11. Brochure GCA P-1, LA MANIPULATION SANS RISQUE DES GAZ COMPRIMÉS EN CYLINDRES, disponible auprès de l'Association des Gaz Comprimés (Compressed Gas Association), 1235 Jefferson Davis Highway, Suite 501, Arlington, VA 22202
12. Norme CSA W117.2, CODE DE SÉCURITÉ POUR LE SOUDAGE ET LA COUPE, disponible auprès de l'Association des Normes Canadiennes, Standards Sales, 178 Rexdale Boulevard, Rexdale, Ontario, Canada, M9W 1R3
13. Livret NWSA, BIBLIOGRAPHIE SUR LA SÉCURITÉ DU SOUDAGE, disponible auprès de l'Association Nationale de Fournitures de Soudage (National Welding Supply Association), 1900 Arch Street, Philadelphia, PA 19103
14. Norme AWSF4.1 de l'Association Américaine de Soudage, RECOMMANDATIONS DE PRATIQUES SURES POUR LA PRÉPARATION À LA COUPE ET AU SOUDAGE DE CONTENEURS ET TUYAUX AYANT RENFERMÉ DES PRODUITS DANGEREUX , disponible auprès de la American Welding Society, 550 N.W. LeJeune Rd., Miami, FL 33126
15. Norme ANSI Z88.2, PRATIQUES DE PROTECTION RESPIRATOIRE, disponible auprès de l'American National Standards Institute, 1430 Broadway, New York, NY 10018

CUTMASTER 40mm

1.07 Declaration of Conformity

Manufacturer: Thermal Dynamics Corporation
Address: 82 Benning Street
West Lebanon, New Hampshire 03784
USA

The equipment described in this manual conforms to all applicable aspects and regulations of the 'Low Voltage Directive' (2006/95 EC) and to the National legislation for the enforcement of this Directive.

The equipment described in this manual conforms to all applicable aspects and regulations of the "EMC Directive" (European Council Directive 89/336/EEC) and to the National legislation for the enforcement of this Directive.

Serial numbers are unique with each individual piece of equipment and details description, parts used to manufacture a unit and date of manufacture.

National Standard and Technical Specifications

The product is designed and manufactured to a number of standards and technical requirements. Among them are:

- * CSA (Canadian Standards Association) standard C22.2 number 60 for Arc welding equipment.
- * UL (Underwriters Laboratory) rating 94VO flammability testing for all printed-circuit boards used.
- * CENELEC EN50199 EMC Product Standard for Arc Welding Equipment.
- * ISO/IEC 60974-1 (BS 638-PT10) (EN 60 974-1) (EN50192) (EN50078) applicable to plasma cutting equipment and associated accessories.
- * For environments with increased hazard of electrical shock, Power Supplies bearing the 'S' mark conform to EN50192 when used in conjunction with hand torches with exposed cutting tips, if equipped with properly installed standoff guides.
- * Extensive product design verification is conducted at the manufacturing facility as part of the routine design and manufacturing process. This is to ensure the product is safe, when used according to instructions in this manual and related industry standards, and performs as specified. Rigorous testing is incorporated into the manufacturing process to ensure the manufactured product meets or exceeds all design specifications.

Thermal Dynamics has been manufacturing products for more than 30 years, and will continue to achieve excellence in our area of manufacture.

Manufacturers responsible representative: Steve Ward
Operations Director
Thermadyne Europe
Europa Building
Chorley N Industrial Park
Chorley, Lancashire,
England PR6 7BX



1.08 Statement of Warranty

LIMITED WARRANTY: Subject to the terms and conditions established below, Thermal Dynamics® Corporation warrants to the original retail purchaser that new Thermal Dynamics CUTMASTER™ 1Series plasma cutting systems sold after the effective date of this warranty are free of defects in material and workmanship. Should any failure to conform to this warranty appear within the applicable period stated below, Thermal Dynamics Corporation shall, upon notification thereof and substantiation that the product has been stored operated and maintained in accordance with Thermal Dynamics' specifications, instructions, recommendations and recognized industry practice, correct such defects by suitable repair or replacement.

This warranty is exclusive and in lieu of any warranty of merchantability or fitness for a particular purpose.

Thermal Dynamics will repair or replace, at its discretion, any warranted parts or components that fail due to defects in material or workmanship within the time periods set out below. Thermal Dynamics Corporation must be notified within 30 days of any failure, at which time Thermal Dynamics Corporation will provide instructions on the warranty procedures to be implemented.

Thermal Dynamics Corporation will honor warranty claims submitted within the warranty periods listed below. All warranty periods begin on the date of sale of the product to the original retail customer or 1 year after sale to an authorized Thermal Dynamics Distributor.

LIMITED WARRANTY PERIOD

| Product | Power Supply Components (Parts and Labor) | Torch and Leads (Parts and Labor) |
|---------------|--|--------------------------------------|
| CUTMASTER™ 10 | 3 Years | 1 Year |
| CUTMASTER™ 12 | 3 Years | 1 Year |
| CUTMASTER™ 20 | 3 Years | 1 Year |
| CUTMASTER™ 25 | 3 Years | 1 Year |
| CUTMASTER™ 35 | 3 Years | 1 Year |
| CUTMASTER™ 40 | 3 Years | 1 Year |

This warranty does not apply to:

1. Consumable Parts, such as tips, electrodes, shield cups, o - rings, starter cartridges, gas distributors, fuses, filters.
2. Equipment that has been modified by an unauthorized party, improperly installed, improperly operated or misused based upon industry standards.

In the event of a claim under this warranty, the remedies shall be, at the discretion of Thermal Dynamics Corporation:

1. Repair of the defective product.
2. Replacement of the defective product.
3. Reimbursement of reasonable costs of repair when authorized in advance by Thermal Dynamics.
4. Payment of credit up to the purchase price less reasonable depreciation based on actual use.

These remedies may be authorized by Thermal Dynamics and are FOB West Lebanon, NH or an authorized Thermadyne service station. Product returned for service is at the owner's expense and no reimbursement of travel or transportation is authorized.

LIMITATION OF LIABILITY: Thermal Dynamics Corporation shall not under any circumstances be liable for special or consequential damages such as, but not limited to, damage or loss of purchased or replacement goods or claims of customer or distributors (hereinafter "Purchaser") for service interruption. The remedies of the Purchaser set forth herein are exclusive and the liability of Thermal Dynamics with respect to any contract, or anything done in connection therewith such as the performance or breach thereof, or from the manufacture, sale, delivery, resale, or use of the goods covered by or furnished by Thermal Dynamics whether arising out of contract, negligence, strict tort, or under any warranty, or otherwise, shall not, except as expressly provided herein, exceed the price of the goods upon which liability is based.

This warranty becomes invalid if replacement parts or accessories are used which may impair the safety or performance of any Thermal Dynamics product.

This warranty is invalid if the Thermal Dynamics product is sold by non - authorized persons.

Effective September 4, 2007

This Page Intentionally Blank

SECTION 2 SYSTEM: INTRODUCTION

2.01 How To Use This Manual

This Service Manual applies to just specification or part numbers listed on page i.

To ensure safe operation, read the entire manual, including the chapter on safety instructions and warnings.

Throughout this manual, the words **WARNING**, **CAUTION**, and **NOTE** may appear. Pay particular attention to the information provided under these headings. These special annotations are easily recognized as follows:



WARNING

A WARNING gives information regarding possible personal injury.



CAUTION

A CAUTION refers to possible equipment damage.

NOTE

A NOTE offers helpful information concerning certain operating procedures.

Additional copies of this manual may be purchased by contacting Thermadyne at the address and phone number in your area listed in the inside back cover of this manual. Include the Service Manual number and equipment identification numbers.

Electronic copies of this manual can also be downloaded at no charge in Acrobat PDF format by going to the

Thermal Dynamics web site listed below and clicking on Thermal Dynamics and then on the Literature link:

<http://www.thermal-dynamics.com>

2.02 Equipment Identification

The unit's identification number (specification or part number), model, and serial number usually appear on a data tag attached to the rear panel. Equipment which does not have a data tag such as torch and cable assemblies are identified only by the specification or part number printed on loosely attached card or the shipping container. Record these numbers on the bottom of page 1 for future reference.

2.03 Receipt Of Equipment

When you receive the equipment, check it against the invoice to make sure it is complete and inspect the equipment for possible damage due to shipping. If there is any damage, notify the carrier immediately to file a claim. Furnish complete information concerning damage claims or shipping errors to the location in your area listed in the inside back cover of this manual.

Include all equipment identification numbers as described above along with a full description of the parts in error.

Move the equipment to the installation site before un-crating the unit. Use care to avoid damaging the equipment when using bars, hammers, etc., to un-crate the unit.

CUTMASTER 40mm

2.04 Power Supply Specifications

| CutMaster 40mm Power Supply Specifications | | | | |
|--|---|-----|-------|------|
| Input Power | 380 VAC (360 - 440 VAC), Three Phase, 50/60 Hz | | | |
| | 400/415 VAC (360 - 440 VAC), Three Phase, 50 Hz | | | |
| Input Power Cable | Power Supply includes input cable. | | | |
| Output Current | 30 - 120 Amps, Continuously Adjustable | | | |
| Power Supply Gas Filtering Ability | Particulates to 5 Microns | | | |
| CutMaster 40mm Power Supply Duty Cycle * | | | | |
| Ambient Temperature | Duty Cycle Ratings @ 40° C (104° F) Operating Range 0° - 50° C | | | |
| All Units | Duty Cycle | N/A | 80%** | 100% |
| | Current | | 120 | 110 |
| | | IEC | IEC | IEC |
| | DC Voltage | | 128 | 124 |
| * NOTE: The duty cycle will be reduced if the primary input power (AC) is low or the output voltage (DC) is higher than shown in this chart. | | | | |

NOTE

IEC Rating is determined as specified by the International Electro-Technical Commission. These specifications include calculating an output voltage based upon power supply rated current. To facilitate comparison between power supplies, all manufacturers use this output voltage to determine duty cycle.

Power Supply Dimensions & Weight

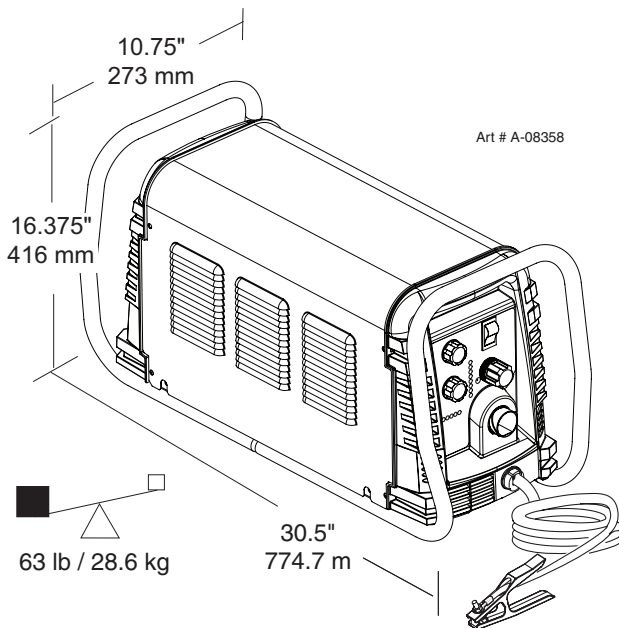

Ventilation Clearance Requirements

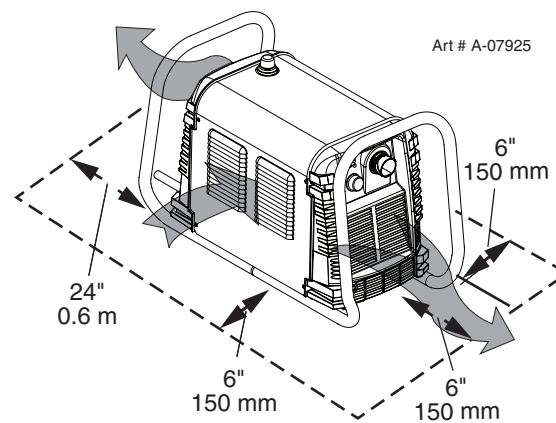

2.05 Input Wiring Specifications

| CutMaster 40mm Power Supply Input Cable Wiring Requirements | | | | | | | |
|--|---------------|------|-------------|-------|-------|-----------------|--------------------------|
| | Input voltage | Freq | Power Input | | | Suggested Sizes | |
| | Volts | Hz | kVA | I max | I eff | Fuse (amps) | Flexible Cord (Min. AWG) |
| 3 Phase | 380 | 50 | 23 | 35 | 32 | 40 | 8 |
| | 400/415 | 50 | 23.6 | 34 | 31 | 40 | 8 |
| Line Voltages with Suggested Circuit Protection and Wire Sizes Based on National Electric Code and Canadian Electric Code | | | | | | | |

NOTES

Refer to Local and National Codes or local authority having jurisdiction for proper wiring requirements.

The suggested sizes are based on flexible power cable with power plug installations. For hard-wired installations refer to local or national codes.

I_{1max} is taken at TDC rated minimum duty cycle.

I_{1eff} is taken at TDC 100% rated duty cycle.

2.06 Power Supply Features

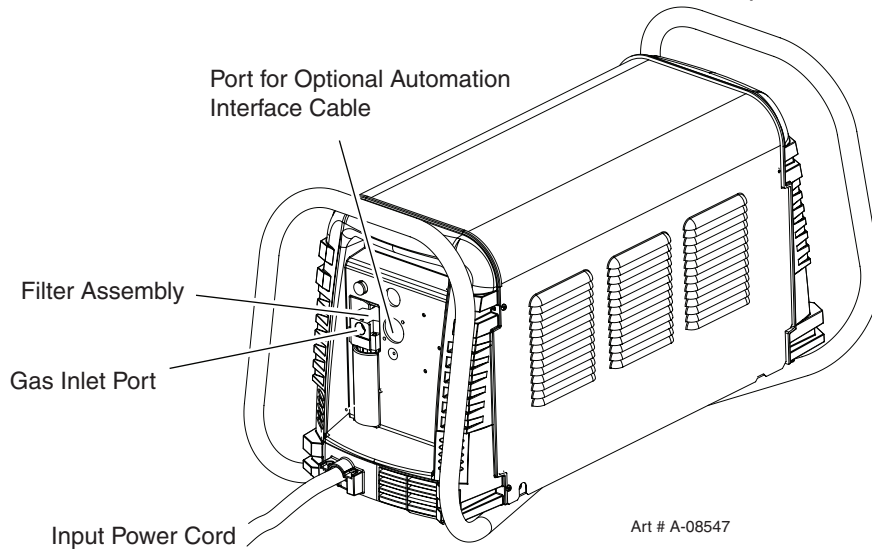
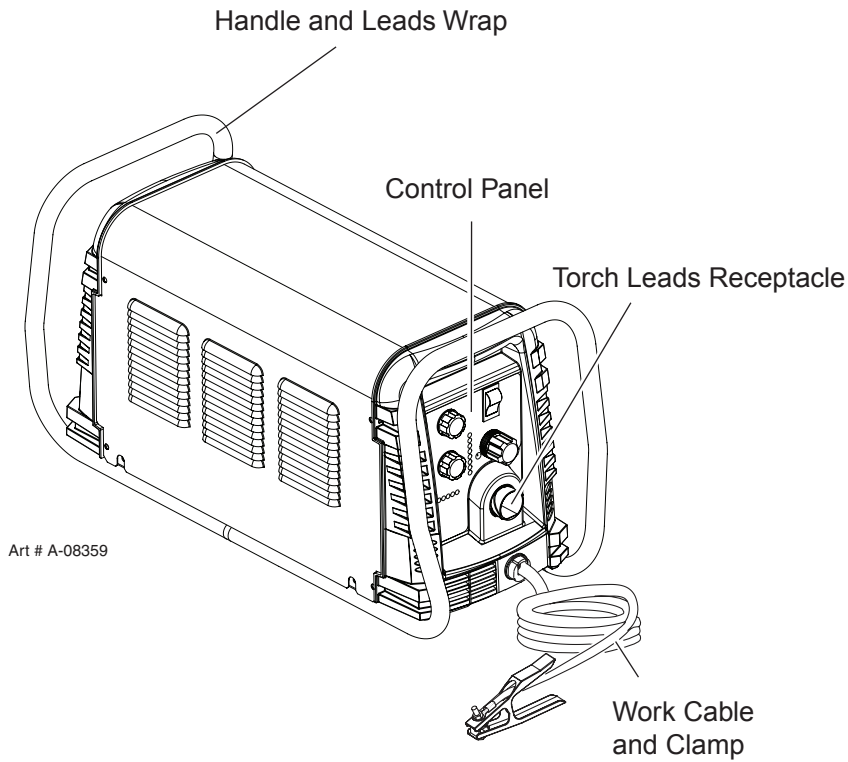

SECTION 2 TORCH: INTRODUCTION

2T.01 Scope of Manual

This manual contains descriptions, operating instructions and maintenance procedures for the 1 Torch Models SL100/Manual and SL100/Mechanized Plasma Cutting Torches. Service of this equipment is restricted to properly trained personnel; unqualified personnel are strictly cautioned against attempting repairs or adjustments not covered in this manual, at the risk of voiding the Warranty.

Read this manual thoroughly. A complete understanding of the characteristics and capabilities of this equipment will assure the dependable operation for which it was designed.

2T.02 General Description

Plasma torches are similar in design to the automotive spark plug. They consist of negative and positive sections separated by a center insulator. Inside the torch, the pilot arc starts in the gap between the negatively charged electrode and the positively charged tip. Once the pilot arc has ionized the plasma gas, the superheated column of gas flows through the small orifice in the torch tip, which is focused on the metal to be cut.

A single torch lead provides gas from a single source to be used as both the plasma and secondary gas. The air flow is divided inside the torch head. Single - gas operation provides a smaller sized torch and inexpensive operation.

NOTE

Refer to Section 2T.05, Introduction To Plasma, for a more detailed description of plasma torch operation.

Refer to the Appendix Pages for additional specifications as related to the Power Supply used.

2T.03 Specifications

A. Torch Configurations

1. Hand/Manual Torch, Models

The hand torch head is at 75° to the torch handle. The hand torches include a torch handle and torch trigger assembly.

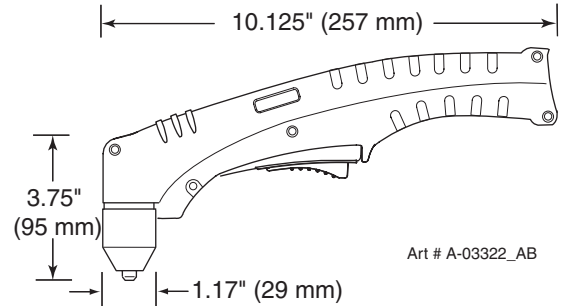

2. Mechanized Torch, Model

The standard machine torch has a positioning tube with rack & pinch block assembly.

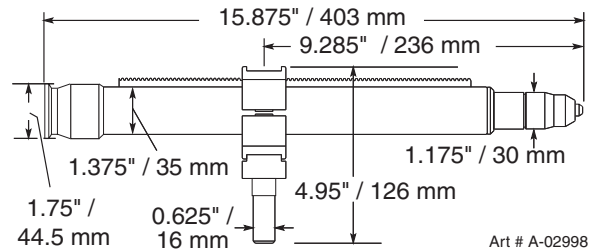

B. Torch Leads Lengths

Hand Torches are available as follows:

- 20 ft / 6.1 m, with ATC connectors
- 50 ft / 15.2 m, with ATC connectors

Machine Torches are available as follows:

- 5 foot / 1.5 m, with ATC connectors
- 10 foot / 3.05 m, with ATC connectors
- 25 foot / 7.6 m, with ATC connectors
- 50 foot / 15.2 m, with ATC connectors

C. Torch Parts

Starter Cartridge, Electrode, Tip, Shield Cup

D. Parts - In - Place (PIP)

Torch Head has built - in switch

12 vdc circuit rating

E. Type Cooling

Combination of ambient air and gas stream through torch.

CUTMASTER 40mm

F. Torch Ratings

| Manual Torch Ratings | |
|------------------------------|----------------------------|
| Ambient Temperature | 104° F 40° C |
| Duty Cycle | 100% @ 120 Amps @ 400 scfh |
| Maximum Current | 120 Amps |
| Voltage (V _{peak}) | 500V |
| Arc Striking Voltage | 7kV |

| Mechanized Torch Ratings | |
|------------------------------|----------------------------|
| Ambient Temperature | 104° F 40° C |
| Duty Cycle | 100% @ 120 Amps @ 400 scfh |
| Maximum Current | 120 Amps |
| Voltage (V _{peak}) | 500V |
| Arc Striking Voltage | 7kV |

G. Gas Requirements

| Manual and Mechanized Torch Gas Specifications | |
|--|---------------------------------|
| Gas (Plasma and Secondary) | Compressed Air |
| Operating Pressure <i>Refer to NOTE</i> | 60 - 95 psi 4.1 - 6.5 bar |
| Maximum Input Pressure | 125 psi / 8.6 bar |
| Gas Flow (Cutting and Gouging) | 300 - 500 scfh 142 - 235 lpm |



WARNING

This torch is not to be used with oxygen (O₂).

NOTE

Operating pressure varies with torch model, operating amperage, and torch leads length. Refer to gas pressure settings charts for each model.

H. Direct Contact Hazard

For standoff tip the recommended standoff is 3/16 inches / 4.7 mm.

2T.04 Options And Accessories

For options and accessories, see section 6.

2T.05 Introduction to Plasma

A. Plasma Gas Flow

Plasma is a gas which has been heated to an extremely high temperature and ionized so that it becomes electrically conductive. The plasma arc cutting and gouging processes use this plasma to transfer an electrical arc to the workpiece. The metal to be cut or removed is melted by the heat of the arc and then blown away.

While the goal of plasma arc cutting is separation of the material, plasma arc gouging is used to remove metals to a controlled depth and width.

In a Plasma Cutting Torch a cool gas enters Zone B, where a pilot arc between the electrode and the torch tip heats and ionizes the gas. The main cutting arc then transfers to the workpiece through the column of plasma gas in Zone C.

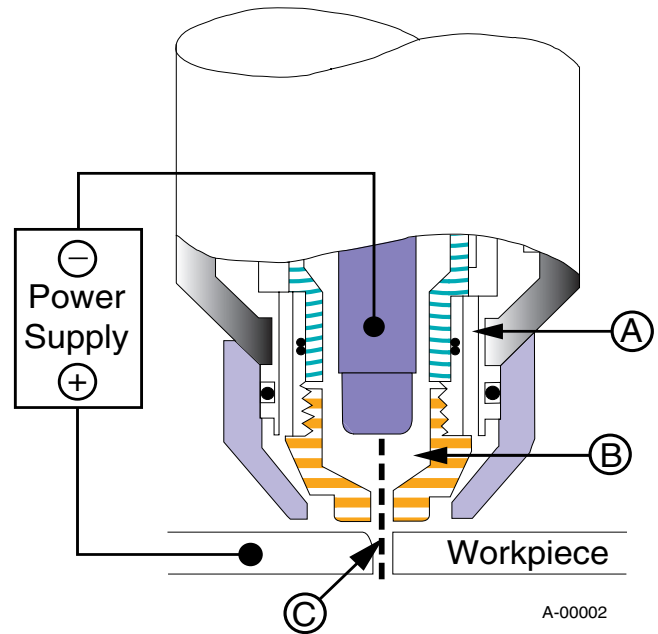

Typical Torch Head Detail

By forcing the plasma gas and electric arc through a small orifice, the torch delivers a high concentration of heat to a small area. The stiff, constricted plasma arc is shown in Zone C. Direct current (DC) straight polarity is used for plasma cutting, as shown in the illustration.

Zone A channels a secondary gas that cools the torch. This gas also assists the high velocity plasma gas in blowing the molten metal out of the cut allowing for a fast, slag - free cut.

B. Gas Distribution

The single gas used is internally split into plasma and secondary gases.

The plasma gas flows into the torch through the negative lead, through the starter cartridge, around the electrode, and out through the tip orifice.

The secondary gas flows down around the outside of the torch starter cartridge, and out between the tip and shield cup around the plasma arc.

C. Pilot Arc

When the torch is started a pilot arc is established between the electrode and cutting tip. This pilot arc creates a path for the main arc to transfer to the work.

D. Main Cutting Arc

DC power is also used for the main cutting arc. The negative output is connected to the torch electrode through the torch lead. The positive output is connected to the workpiece via the work cable and to the torch through a pilot wire.

E. Parts - In - Place (PIP)

The torch includes a 'Parts - In - Place' (PIP) circuit. When the shield cup is properly installed, it closes a switch. The torch will not operate if this switch is open.

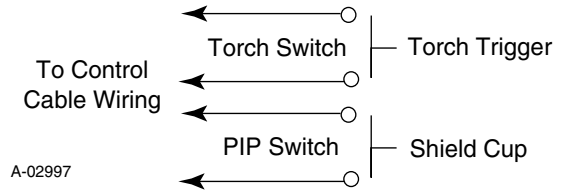

Parts - In - Place Circuit Diagram for Hand Torch

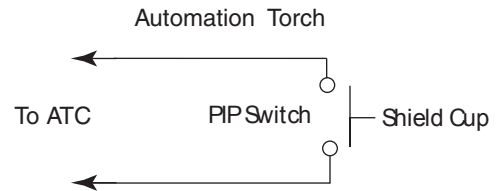
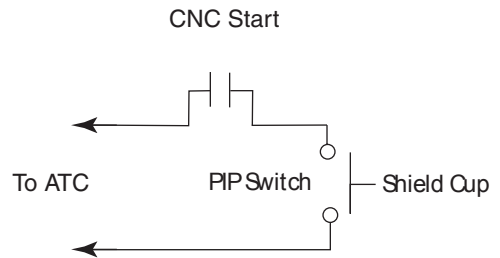
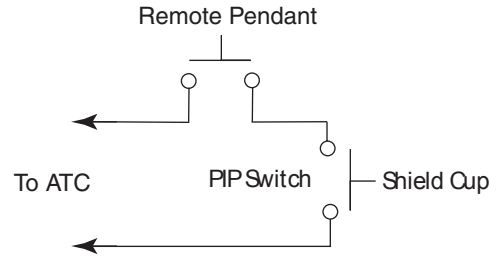

Parts - In - Place Circuit Diagram for Machine Torch

Art # A-08168

This Page Intentionally Blank

SECTION 3 SYSTEM: INSTALLATION

3.01 Unpacking

1. Use the packing lists to identify and account for each item.
2. Inspect each item for possible shipping damage. If damage is evident, contact your distributor and / or shipping company before proceeding with the installation.
3. Record Power Supply and Torch model and serial numbers, purchase date and vendor name, in the information block at the front of this manual.

3.02 Lifting Options

The Power Supply includes a handle for **hand lifting only**. Be sure unit is lifted and transported safely and securely.



Do not touch live electrical parts.

Disconnect input power cord before moving unit.

***FALLING EQUIPMENT** can cause serious personal injury and can damage equipment.*

***HANDLE** is not for mechanical lifting.*

- Only persons of adequate physical strength should lift the unit.
- Lift unit by the handles, using two hands. Do not use straps for lifting.
- Use optional cart or similar device of adequate capacity to move unit.
- Place unit on a proper skid and secure in place before transporting with a fork lift or other vehicle.

3.03 Primary Input Power Connections



CAUTION

Check your power source for correct voltage before plugging in or connecting the unit. The primary power source, fuse, and any extension cords used must conform to local electrical code and the recommended circuit protection and wiring requirements as specified in Section 2.

Connections for Three Phase Input Power



WIRING

Disconnect input power from the power supply and input cable before attempting this procedure.

These instructions are for installing the input power cable to the power supply and connecting to 380/400/415VAC three phase Primary Input Power.

1. Remove the Power Supply cover per instructions found in section 5.
2. Loosen the strain relief on the back panel of the power supply.
3. Using a customer supplied four conductor input power cable for rated voltage, strip back the insulation on the individual wires.
4. Pass the cable being used through the input cable opening / strain relief in the back panel of the power supply. Refer to Section 2 for power cable specifications.



CAUTION

The primary power source and power cable must conform to local electrical code and the recommended circuit protection and wiring requirements (refer to table in Section 2).

5. Connect the wires as follows.
For non CE units:

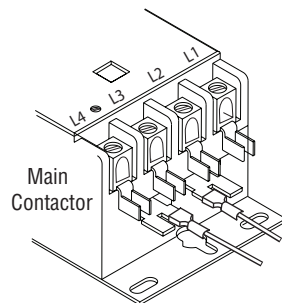

Ground Terminal

Art # A-08753

- Three phase wires to L1, L2 and L3 on the W1 contactor. It does not matter what order these wires are attached. See previous illustration and on label in the power supply.
- Green / Yellow wire to Ground Terminal.

For CE units:

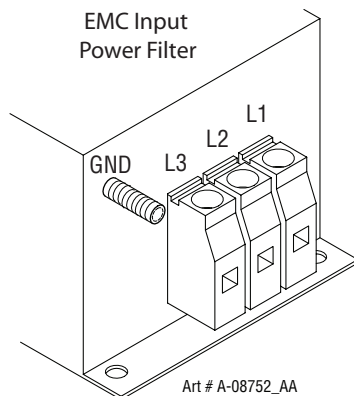

- Three phase wires to L1, L2 and L3 on the CE Input Power Filter. It does not matter what order these wires are attached. See previous illustration and on label in the power supply.
 - Green / Yellow wire to Ground.
6. With a little slack in the wires, tighten the strain relief to secure the power cable.
 7. Reinstall the Power Supply cover.
 8. Connect the opposite end of individual wires to a customer supplied plug and plug into an appropriate input power receptacle.(or connect directly to main disconnect)
 9. Close the main disconnect switch to supply power to the unit..

3.04 Gas Connections

Connecting Gas Supply to Unit

The connection is the same for compressed air or high pressure cylinders. Refer to the following two subsections if an optional air line filter is to be installed.

1. Connect the air line to the inlet port. The illustration shows typical fittings as an example.

NOTE

For a secure seal, apply thread sealant to the fitting threads, according to manufacturer's instructions. Do not use Teflon tape as a thread sealer, as small particles of the tape may break off and block the small air passages in the torch.

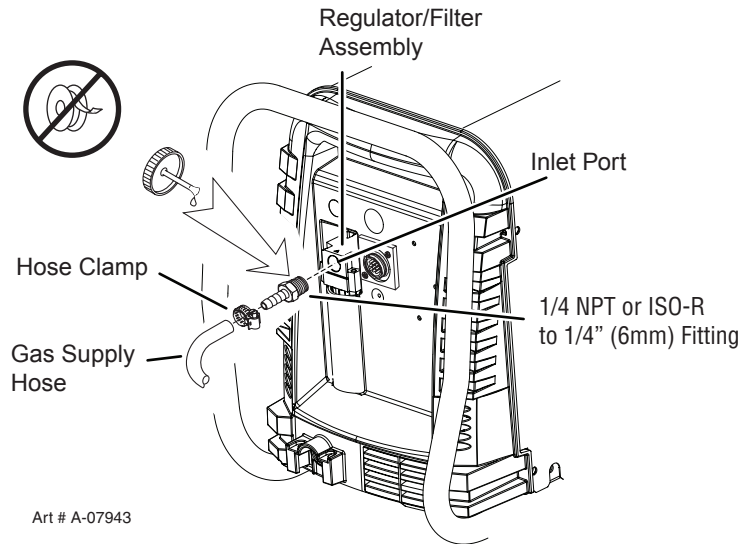

Air Connection to Inlet Port

Installing Optional Single - Stage Air Filter

An optional filter kit is recommended for improved filtering with compressed air, to keep moisture and debris out of the torch.

1. Attach the Single - Stage Filter Hose to the Inlet Port.
2. Attach the Filter Assembly to the filter hose.
3. Connect the air line to the Filter. The illustration shows typical fittings as an example.

NOTE

For a secure seal, apply thread sealant to the fitting threads, according to the maker's instructions. Do Not use Teflon tape as a thread sealer, as small particles of the tape may break off and block the small air passages in the torch. Connect as follows:

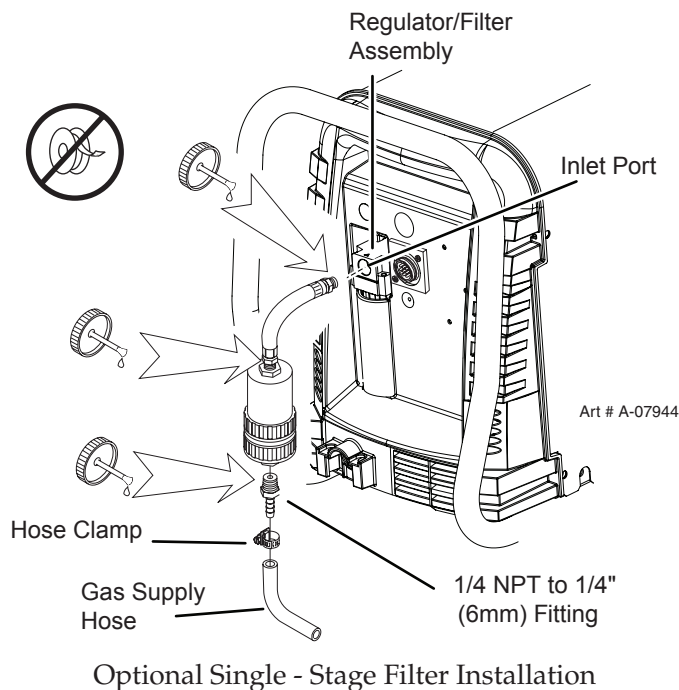

CUTMASTER 40mm

Installing Optional Two - Stage Air Filter Kit

This optional two - stage air line filter is also for use on compressed air shop systems. Filter removes moisture and contaminants to at least 5 microns.

Connect the air supply as follows:

1. Attach the Two Stage Filter bracket to the back of the power supply per instructions supplied with the filter assembly.

NOTE

For a secure seal, apply thread sealant to the fitting threads according to manufacturer's instructions. Do Not use Teflon tape as a thread sealer as small particles of the tape may break off and block the small air passages in the torch.

2. Connect the two stage filter outlet hose to the inlet port of the Regulator / Filter Assembly.
3. Use customer - supplied fittings to connect the air line to the Filter. A 1/4 NPT to 1/4" hose barbed fitting is shown as an example.

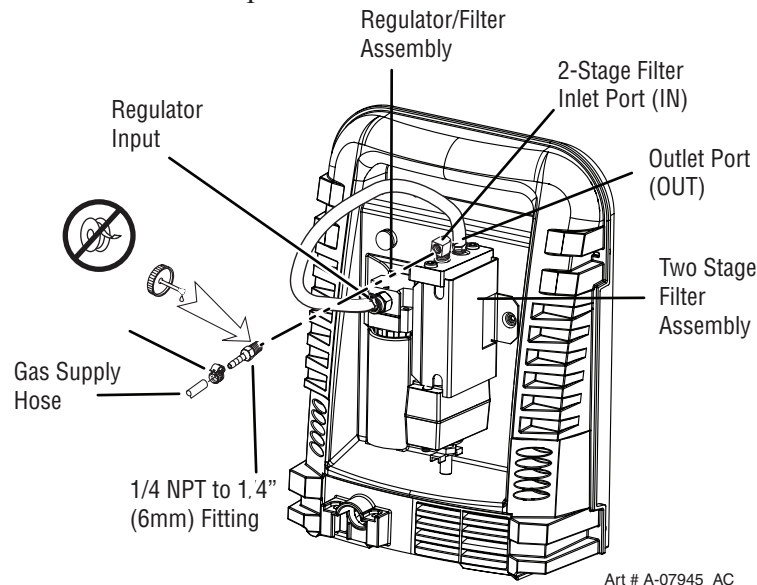

Optional Two - Stage Filter Installation

Using High Pressure Air Cylinders

When using high pressure air cylinders as the air supply:

1. Refer to the manufacturer's specifications for installation and maintenance procedures for high pressure regulators.
2. Examine the cylinder valves to be sure they are clean and free of oil, grease or any foreign material. Briefly open each cylinder valve to blow out any dust which may be present.
3. The cylinder must be equipped with an adjustable high - pressure regulator capable of outlet pressures up to 100 psi (6.9 bar) maximum and flows of at least 300 scfh (141.5 lpm).
4. Connect supply hose to the cylinder.

NOTE

Pressure should be set at 100 psi (6.9 bar) at the high pressure cylinder regulator.

Supply hose must be at least 1/4 inch (6 mm) I.D.

For a secure seal, apply thread sealant to the fitting threads, according to manufacturer's instructions. Do Not use Teflon tape as a thread sealer, as small particles of the tape may break off and block the small air passages in the torch

SECTION 3 TORCH: INSTALLATION

3T.01 Torch Connections

If necessary, connect the torch to the Power Supply. Connect only the Thermal Dynamics model SL100 / Manual or SL100 / Mechanical Torch to this power supply. Maximum torch leads length is 100 feet / 30.5 m, including extensions.



WARNING

Disconnect primary power at the source before connecting the torch.

1. Align the ATC male connector (on the torch lead) with the female receptacle. Push the male connector into the female receptacle. The connectors should push together with a small amount of pressure.
2. Secure the connection by turning the locking nut clockwise until it clicks. **DO NOT** use the locking nut to pull the connection together. Do not use tools to secure the connection.

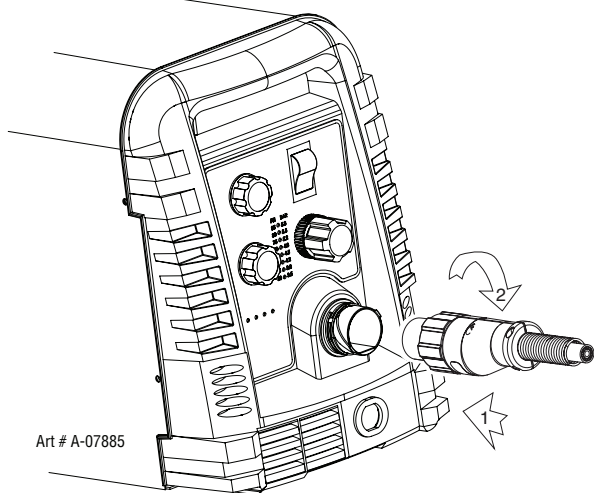

Connecting the Torch to the Power Supply

3. The system is ready for operation.

Check Air Quality

To test the quality of air:

1. Put the ON / OFF switch in the ON (up) position.
2. Put the Function Control switch in the SET position.
3. Place a welding filter lens in front of the torch and turn on the air. **Do not start an arc!**

Any oil or moisture in the air will be visible on the lens.

3T.02 Setting Up Mechanical Torch

NOTE

An adapter is required to be installed in the power supply if converting a hand torch system to operate a machine torch.



WARNING

Disconnect primary power at the source before disassembling the torch or torch leads.

The mechanical torch includes a positioning tube with rack and pinch block assembly.

1. Mount the torch assembly on the cutting table.
2. To obtain a clean vertical cut, use a square to align the torch perpendicular to the surface of the workpiece.

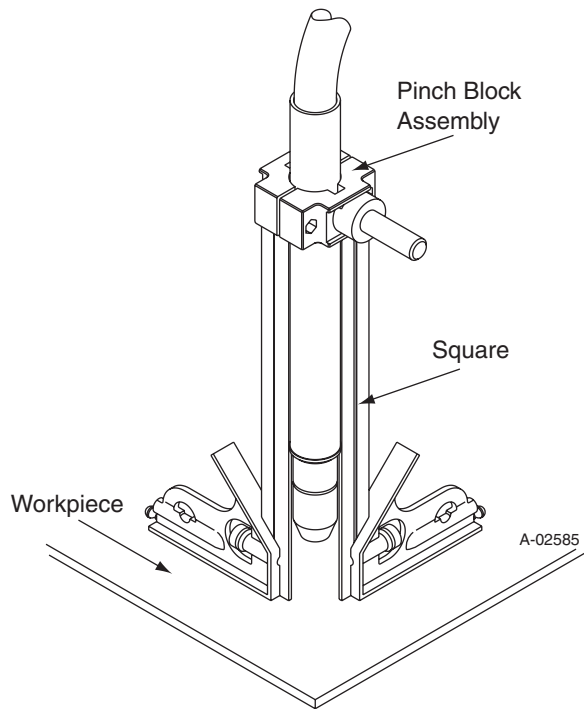

Mechanical Torch Set - Up

3. The proper torch parts (shield cup, tip, start cartridge, and electrode) must be installed for the type of operation. Refer to Section 4T.07, Torch Parts Selection for details.

SECTION 4 SYSTEM: OPERATION

4.01 Front Panel Controls / Features

See Illustration for numbering Identification

1. Output Current Control

Sets the desired output current. Output settings up to 60 Amps may be used for drag cutting (with the torch tip contacting the workpiece) or higher for standoff cutting.



2. Function Control

Function Control Knob, Used to select between the different operating modes.

SET  Used to purge the air through the unit and torch and leads and to adjust gas pressure.

RUN  Used for general cutting operations

RAPID AUTO RESTART  Allows for faster restarting of the Pilot Arc for uninterrupted cutting.

LATCH   Used for longer hand held cuts. Once a cutting arc is established, the torch switch can be released. The cutting arc will remain on until the torch is lifted away from the work piece, the torch leaves the edge of the work piece the torch switch is activated again or if one of the system interlocks is activated.

3. On Off Power Switch

ON  / **OFF**  Switch controls input power to the power supply. Up is ON, down is OFF.

4. Air/Gas Pressure Control

The Pressure  Control is used in the "SET" mode to adjust the air/gas pressure. Pull the knob out to adjust and push in to lock.

5. AC Indicator

Steady light indicates power supply is ready for operation. Blinking light indicates unit is in protective interlock mode. Shut unit off, shut off or disconnect input power, correct the fault, and restart the unit. Refer to Section 5 for details.

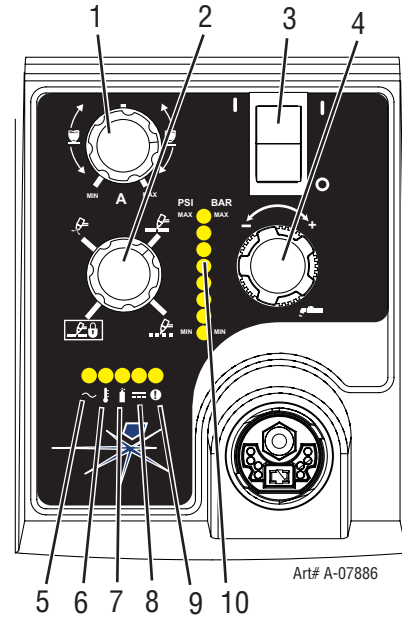

6. Temp Indicator

Indicator is normally OFF. Indicator is ON when internal temperature exceeds normal limits. Let the unit cool before continuing operation.

7. Gas Indicator

Indicator is ON when minimum input gas pressure for power supply operation is present. Minimum pressure for power supply operation is not sufficient for torch operation.

8. DC Indicator

Indicator is ON when DC output circuit is active.

9. Fault Error Indicator

Indicator is ON when Fault circuit is active. See section 5 for explanations of fault lights.

10. Pressure Indicators

| PSI | BAR |
|-----|-----|
| MAX | MAX |
| 90 | 6.3 |
| 85 | 5.9 |
| 80 | 5.5 |
| 75 | 5.2 |
| 70 | 4.8 |
| 65 | 4.5 |
| MIN | MIN |

Art # A-08170

The Indicators will illuminate according to the pressure set by the Pressure Control Knob (number 4).

4.02 Preparations for Operation

At the start of each operating session:



WARNING

Disconnect primary power at the source before assembling or disassembling power supply, torch parts, or torch and leads assemblies.

Torch Parts Selection

Check the torch for proper assembly and appropriate torch parts. The torch parts must correspond with the type of operation, and with the amperage output of this Power Supply (120 amps maximum). Refer to Section 4T.07 and following for torch parts selection.

Torch Connection

Check that the torch is properly connected. Only Thermal Dynamics model SL100 / Manual or SL100 / Mechanical Torches may be connected to this Power Supply. See Section 3T of this manual.

Check Primary Input Power Source

1. Check the power source for proper input voltage. Make sure the input power source meets the power requirements for the unit per Section 2, Specifications.
2. Connect the input power cable (or close the main disconnect switch) to supply power to the system.

Air Source

Ensure source meets requirements (refer to Section 2). Check connections and turn air supply on.

Connect Work Cable

Clamp the work cable to the workpiece or cutting table. The area must be free from oil, paint and rust. Connect only to the main part of the workpiece; do not connect to the part to be cut off.

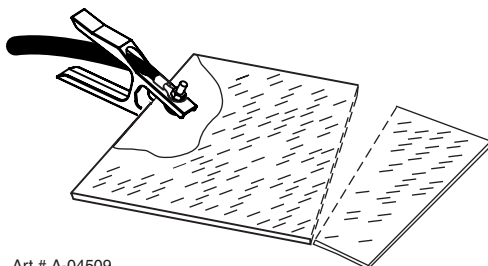

Art # A-04509

Power On

Place the Power Supply ON / OFF switch to the ON (up) position. AC indicator  turns on. Gas

indicator  turns on if there is sufficient gas pressure for power supply operation and the cooling fans turn on.

NOTE

Minimum pressure for power supply operation is lower than minimum for torch operation.

The cooling fans will turn on as soon as the unit is turned on. After the unit is idle for ten (10) minutes the fans will turn off. The fans will come back on as soon as the torch switch (Start Signal) is activated or if the unit is turned off, then turned on again. If an over temperature condition occurs, the fans will continue to run while the condition exists and for a ten (10) minute period once the condition is cleared.

Set Operating Pressure

1. Place the Power Supply Function Control knob to the SET  position. Gas will flow.
2. For Standoff cutting, adjust gas pressure from 70 - 85 psi / 4.8 - 5.9 bar (LED's in center of control panel). Refer to the Standoff chart for pressure setting details.

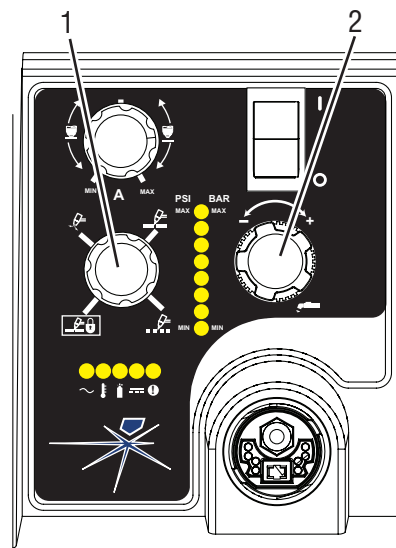

Art# A-07946

| STANDOFF | | |
|--------------------------------------|----------------------|--|
| CutMaster 40mm Gas Pressure Settings | | |
| Leads Length | SL100 (Hand Torch) | SL100 (Mechanized Torch) SL 100 SV (Automation Torch) |
| Up to 50' (7.6 m) | 75 psi 5.2 bar | 75 psi 5.2 bar |
| Each additional 25' (7.6 m) | Add 5 psi 0.4 bar | Add 5 psi 0.4 bar |

- For Drag cutting, adjust gas pressure from 75 - 95 psi / 5.2 - 6.5 bar (LED's in center of control panel). Refer to the Drag Cutting chart for pressure setting details.

| DRAG (60 amps or less) | |
|--------------------------------------|----------------------|
| CutMaster 40mm Gas Pressure Settings | |
| Leads Length | SL100 (Hand Torch) |
| Up to 25' (7.6 m) | 80 psi 5.5 bar |
| Each additional 25' (7.6 m) | Add 5 psi 0.4 bar |

Select Current Output Level

- Place the Function Control Knob in one of the three operating positions available:

RUN 

RAPID AUTO RESTART 

or LATCH   . Gas flow stops.

- Set the output current to desired amperage with the Output Current Control Knob.

Cutting Operation

When the torch leaves the workpiece during cutting operations with the Function Control Knob in the RUN position, there is a brief delay in restarting the pilot arc. With the knob in the **RAPID AUTO RESTART** position, when the torch leaves the workpiece the pilot arc restarts instantly, and the cutting arc restarts instantly when the pilot arc contacts the workpiece. (Use the 'Rapid Auto Restart' position when cutting expanded metal or gratings, or in gouging or trimming operations when an uninterrupted restart is desired). And with the knob in the

LATCH position the main cutting arc will be maintained after the torch switch is released.

Typical Cutting Speeds



Cutting speeds vary according to torch output amperage, the type of material being cut, and operator skill. Refer to Section 4T.08 and following for greater details.

Output current setting or cutting speeds may be reduced to allow slower cutting when following a line, or using a template or cutting guide while still producing cuts of excellent quality.

Postflow

Release the trigger to stop the cutting arc. Gas continues to flow for approximately 20 seconds. During post - flow, if the user moves the trigger release to the rear and presses the trigger, the pilot arc starts. The main arc transfers to the workpiece if the torch tip is within transfer distance to the workpiece.

Shutdown

Turn the ON  / OFF  switch to OFF  (down). All Power Supply indicators shut off. Unplug the input power cord or disconnect input power. Power is removed from the system.

This Page Intentionally Blank

SECTION 4 TORCH: OPERATION

4T.01 Torch Parts Selection

Depending on the type of operation to be done determines the torch parts to be used.

Type of operation:

Drag cutting, standoff cutting or gouging

Torch parts:

Shield Cup, Cutting Tip, Electrode and Starter Cartridge

NOTE

Refer to Section 4T.07 and following for additional information on torch parts.

Change the torch parts for a different operation as follows:



WARNING

Disconnect primary power at the source before assembling or disassembling torch parts, or torch and leads assemblies.

NOTE

The shield cup holds the tip and starter cartridge in place. Position the torch with the shield cup facing upward to keep these parts from falling out when the cup is removed.

1. Unscrew and remove the shield cup assembly from the torch head.

2. Remove the Electrode by pulling it straight out of the Torch Head.

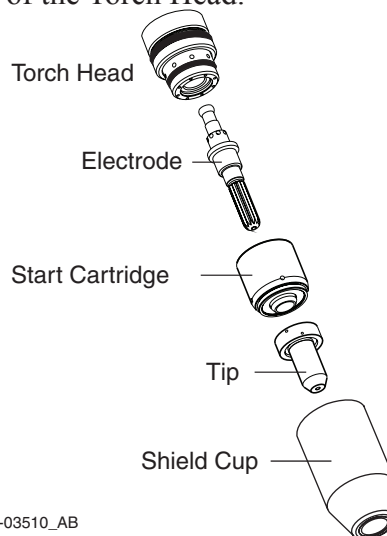

A-03510_AB

Torch Parts (Drag Shield Cap & Shield Cup Body Shown)

3. Install the replacement Electrode by pushing it straight into the torch head until it clicks.
4. Install the starter cartridge and desired tip for the operation into the torch head.
5. Hand tighten the shield cup assembly until it is seated on the torch head. If resistance is felt when installing the cup, check the threads before proceeding.

4T.02 Cut Quality

NOTES

Cut quality depends heavily on setup and parameters such as torch standoff, alignment with the workpiece, cutting speed, gas pressures, and operator ability.

Cut quality requirements differ depending on application. For instance, nitride build - up and bevel angle may be major factors when the surface will be welded after cutting. Dross - free cutting is important when finish cut quality is desired to avoid a secondary cleaning operation. The following cut quality characteristics are illustrated in the following figure:

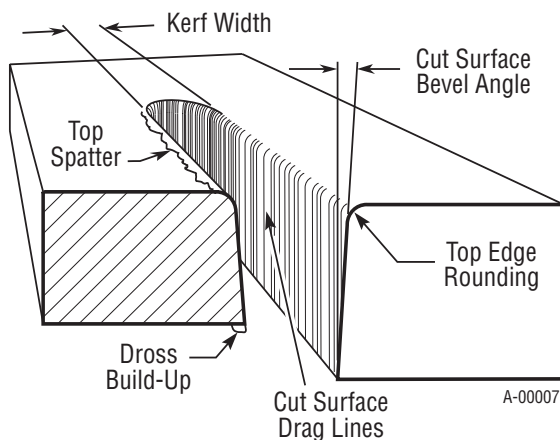

Cut Quality Characteristics

Cut Surface

The desired or specified condition (smooth or rough) of the face of the cut.

Nitride Build - Up

Nitride deposits can be left on the surface of the cut when nitrogen is present in the plasma gas stream. These buildups may create difficulties if the material is to be welded after the cutting process.

Bevel Angle

The angle between the surface of the cut edge and a plane perpendicular to the surface of the plate. A perfectly perpendicular cut would result in a 0° bevel angle.

Top - Edge Rounding

Rounding on the top edge of a cut due to wearing from the initial contact of the plasma arc on the workpiece.

Bottom Dross Buildup

Molten material which is not blown out of the cut area and resolidifies on the plate. Excessive dross may require secondary cleanup operations after cutting.

Kerf Width

The width of the cut (or the width of material removed during the cut).

Top Spatter (Dross)

Top spatter or dross on the top of the cut caused by slow travel speed, excess cutting height, or cutting tip whose orifice has become elongated.

4T.03 General Cutting Information



WARNINGS

Disconnect primary power at the source before disassembling the power supply, torch, or torch leads.

Frequently review the Important Safety Precautions at the front of this manual. Be sure the operator is equipped with proper gloves, clothing, eye and ear protection. Make sure no part of the operator's body comes into contact with the workpiece while the torch is activated.



CAUTION

Sparks from the cutting process can cause damage to coated, painted, and other surfaces such as glass, plastic and metal.

NOTE

Handle torch leads with care and protect them from damage.

Piloting

Piloting is harder on parts life than actual cutting because the pilot arc is directed from the electrode to the tip rather than to a workpiece. Whenever possible, avoid excessive pilot arc time to improve parts life.

Torch Standoff

Improper standoff (the distance between the torch tip and workpiece) can adversely affect tip life as well as shield cup life. Standoff may also significantly affect the bevel angle. Reducing standoff will generally result in a more square cut.

Edge Starting

For edge starts, hold the torch perpendicular to the workpiece with the front of the tip near (not touching) the edge of the workpiece at the point where the cut is to start. When starting at the edge of the plate, do not pause at the edge and force the arc to "reach" for the edge of the metal. Establish the cutting arc as quickly as possible.

Direction of Cut

In the torches, the plasma gas stream swirls as it leaves the torch to maintain a smooth column of gas. This swirl effect results in one side of a cut being more square than the other. Viewed along the direction of travel, the right side of the cut is more square than the left.

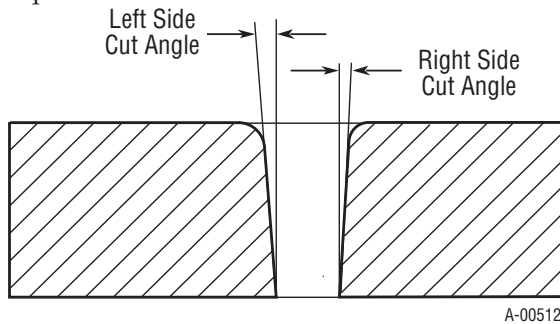

Side Characteristics Of Cut

To make a square - edged cut along an inside diameter of a circle, the torch should move counterclockwise around the circle. To keep the square edge along an outside diameter cut, the torch should travel in a clockwise direction.

Dross

When dross is present on carbon steel, it is commonly referred to as either "high speed, slow speed, or top dross". Dross present on top of the plate is normally caused by too great a torch to plate distance. "Top dross" is normally very easy to remove and can often be wiped off with a welding glove. "Slow speed dross" is normally present on the bottom edge of the plate. It can vary from a light to heavy bead, but does not adhere tightly to the cut edge, and can be easily scraped off. "High speed dross" usually forms a narrow bead along the bottom of the cut edge and is very difficult to remove. When cutting a troublesome steel, it is sometimes useful to reduce the cutting speed to produce "slow speed dross". Any resultant cleanup can be accomplished by scraping, not grinding.

4T.04 Hand Torch Operation

Standoff Cutting With Hand Torch

NOTE

For best performance and parts life, always use the correct parts for the type of operation.

1. The torch can be comfortably held in one hand or steadied with two hands. Position the hand to press the Trigger on the torch handle. With the hand torch, the hand may be positioned close to the torch head for maximum control or near the back end for maximum heat protection. Choose the holding technique that feels most comfortable and allows good control and movement.

NOTE

The tip should never come in contact with the workpiece except during drag cutting operations.

CUTMASTER 40mm

2. Depending on the cutting operation, do one of the following:
 - a. For **edge starts**, hold the torch perpendicular to the workpiece with the front of the tip on the edge of the workpiece at the point where the cut is to start.
 - b. For **standoff cutting**, hold the torch $1/8 - 3/8$ in (3-9 mm) from the workpiece as shown below.

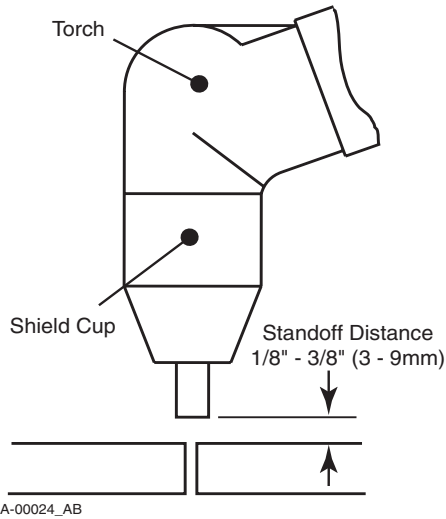

Standoff Distance

3. Hold the torch away from your body.
4. Slide the trigger release toward the back of the torch handle while simultaneously squeezing the trigger. The pilot arc will start.

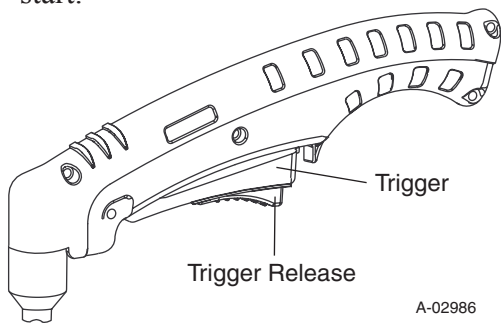

5. Bring the torch within transfer distance to the work. The main arc will transfer to the work, and the pilot arc will shut off.

NOTE

The gas preflow and postflow are a characteristic of the power supply and not a function of the torch.

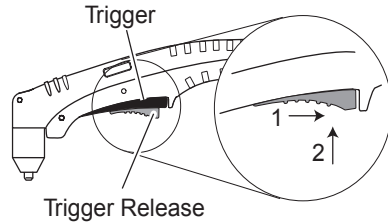

Trigger Release

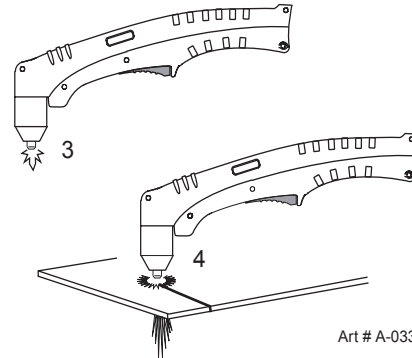

6. Cut as usual. Simply release the trigger assembly to stop cutting.
7. Follow normal recommended cutting practices as provided in the power supply operator's manual.

NOTE

When the shield cup is properly installed, there is a slight gap between the shield cup and the torch handle. Gas vents through this gap as part of normal operation. Do not attempt to force the shield cup to close this gap. Forcing the shield cup against the torch head or torch handle can damage components.

8. For a consistent standoff height from the workpiece, install the standoff guide by sliding it onto the torch shield cup. Install the guide with the legs at the sides of the shield cup body to maintain good visibility of the cutting arc. During operation, position the legs of the standoff guide against the workpiece.

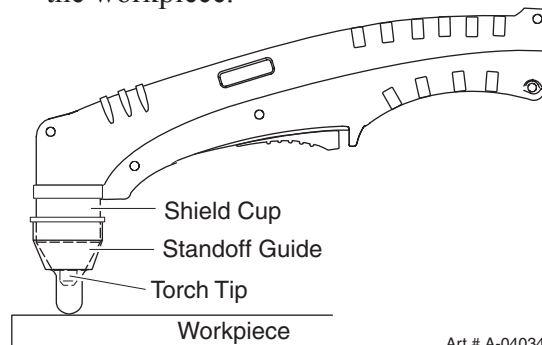

Shield Cup With Straight Edge

The drag shield cup can be used with a non conductive straight edge to make straight cuts by hand.



WARNING

The straight edge *must be non - conductive.*

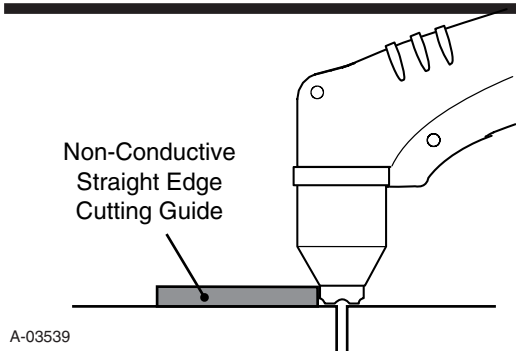

Using Drag Shield Cup With Straight Edge

The crown shield cup functions best when cutting 3/16 inch (4.7 mm) solid metal with relatively smooth surface.

Drag Cutting With a Hand Torch

Drag cutting works best on metal 1/4" (6 mm) thick or less.

NOTE

Drag cutting can only be performed at 60 amps or less.

For best parts performance and life, always use the correct parts for the type of operation.

1. Install the drag cutting tip and set the output current.
2. The torch can be comfortably held in one hand or steadied with two hands. Position the hand to press the Trigger on the torch handle. With the hand torch, the hand may be positioned close to the torch head for maximum control or near the back end for maximum heat protection. Choose the holding technique that feels most comfortable and allows good control and movement.
4. Keep the torch in contact with the work-

piece during the cutting cycle.

5. Hold the torch away from your body.
6. Slide the trigger release toward the back of the torch handle while simultaneously squeezing the trigger. The pilot arc will start.

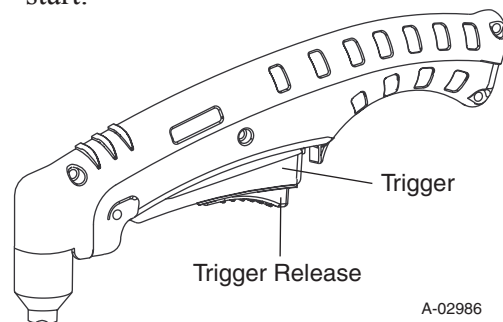

7. Bring the torch within transfer distance to the work. The main arc will transfer to the work, and the pilot arc will shut off.

NOTE

The gas preflow and postflow are a characteristic of the power supply and not a function of the torch.

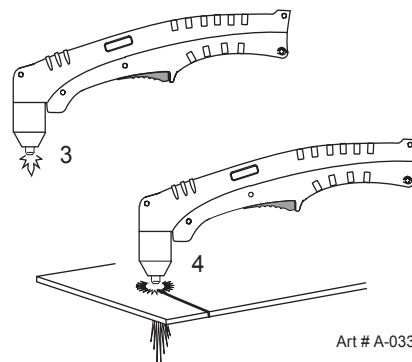
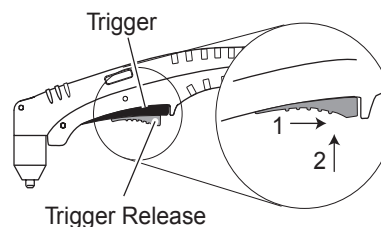

8. Cut as usual. Simply release the trigger assembly to stop cutting.
9. Follow normal recommended cutting practices as provided in the power supply operator's manual.

NOTE

When the shield cup is properly installed, there is a slight gap between the shield cup and the torch handle. Gas vents through this gap as part of normal operation. Do not attempt to force the shield cup to close this gap. Forcing the shield cup against the torch head or torch handle can damage components.

CUTMASTER 40mm

Piercing With Hand Torch

1. The torch can be comfortably held in one hand or steadied with two hands. Position the hand to press the Trigger on the torch handle. With the hand torch, the hand may be positioned close to the torch head for maximum control or near the back end for maximum heat protection. Choose the technique that feels most comfortable and allows good control and movement.

NOTE

The tip should never come in contact with the workpiece except during drag cutting operations.

2. Angle the torch slightly to direct blowback particles away from the torch tip (and operator) rather than directly back into it until the pierce is complete.
3. In a portion of the unwanted metal start the pierce off the cutting line and then continue the cut onto the line. Hold the torch perpendicular to the workpiece after the pierce is complete.
4. Hold the torch away from your body.
5. Slide the trigger release toward the back of the torch handle while simultaneously squeezing the trigger. The pilot arc will start.

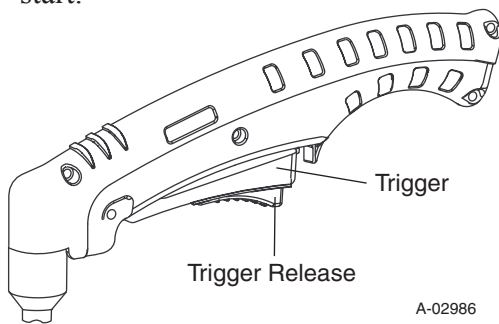

6. Bring the torch within transfer distance to the work. The main arc will transfer to the work, and the pilot arc will shut off.

NOTES

The gas preflow and postflow are a characteristic of the power supply and not a function of the torch.

When the shield cup is properly installed, there is a slight gap between the shield cup and the torch handle. Gas vents through this gap as part of normal operation. Do not attempt to force the shield cup to close this gap. Forcing the shield cup against the torch head or torch handle can damage components.

7. Clean spatter and scale from the shield cup and the tip as soon as possible. Spraying the shield cup in anti - spatter compound will minimize the amount of scale which adheres to it.

Cutting speed depends on material, thickness, and the operator's ability to accurately follow the desired cut line. The following factors may have an impact on system performance:

- Torch parts wear
- Air quality
- Line voltage fluctuations
- Torch standoff height
- Proper work cable connection

4T.05 Gouging



WARNINGS

Be sure the operator is equipped with proper gloves, clothing, eye and ear protection and that all safety precautions at the front of this manual have been followed. Make sure no part of the operator's body comes in contact with the workpiece when the torch is activated.

Disconnect primary power to the system before disassembling the torch, leads, or power supply.



CAUTION

Sparks from plasma gouging can cause damage to coated, painted or other surfaces such as glass, plastic, and metal.

Check torch parts. The torch parts must correspond with the type of operation. Refer to Section 4T.07, Torch Parts Selection.

Gouging Parameters

Gouging performance depends on parameters such as torch travel speed, current level, lead angle (the angle between the torch and workpiece), and the distance between the torch tip and workpiece (standoff).



CAUTION

Touching the torch tip or shield cup to the work surface will cause excessive parts wear.

Torch Travel Speed

NOTE

Refer to Appendix Pages for additional information as related to the Power Supply used.

Optimum torch travel speed is dependent on current setting, lead angle, and mode of operation (hand or machine torch).

Current Setting

Current settings depend on torch travel speed, mode of operation (hand or machine torch), and the amount of material to be removed.

Pressure Setting

Even though the setting is within the specified range, if the torch does not pilot well the pressure may need to be reduced.

Lead Angle

The angle between the torch and workpiece depends on the output current setting and torch travel speed. The recommended lead angle is 35°. At a lead angle greater than 45° the molten metal will not be blown out of the gouge and may be blown back onto the torch. If the lead angle is too small (less than 35°), less material may be removed, requiring more passes. In some applications, such as removing welds or working with light metal, this may be desirable.

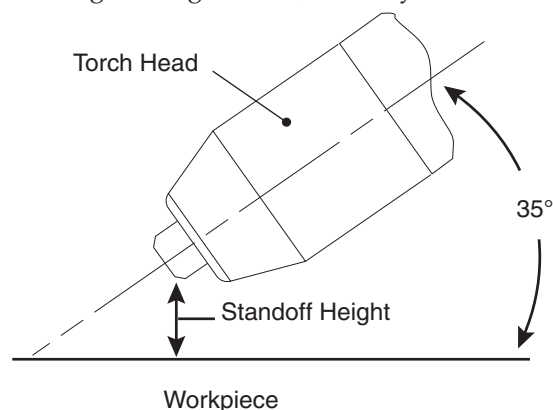

A-00941_AB

Gouging Angle and Standoff Distance

Standoff Distance

The tip to work distance affects gouge quality and depth. Standoff distance of 1/8 - 1/4 inch (3 - 6 mm) allows for smooth, consistent metal removal. Smaller standoff distances may result in a severance cut rather than a gouge. Standoff distances greater than 1/4 inch (6 mm) may result in minimal metal removal or loss of transferred main arc.

Slag Buildup

Slag generated by gouging on materials such as carbon and stainless steels, nickels, and alloyed steels, can be removed easily in most cases. Slag does not obstruct the gouging process if it accumulates to the side of the gouge path. However, slag build-up can cause inconsistencies and irregular metal removal if large amounts of material build up in front of the arc. The build-up is most often a result of improper travel speed, lead angle, or standoff height.

4T.06 Mechanized Torch Operation

Cutting With Mechanized Torch

The mechanized torch can be activated by remote control pendant or by a remote interface device such as CNC.

1. To start a cut at the plate edge, position the center of the torch along the edge of the plate.

Travel Speed

Proper travel speed is indicated by the trail of the arc which is seen below the plate. The arc can be one of the following:

1. Straight Arc

A straight arc is perpendicular to the workpiece surface. This arc is generally recommended for the best cut using air plasma on stainless or aluminum.

2. Leading Arc

The leading arc is directed in the same direction as torch travel. A five degree leading arc is generally recommended for air plasma on mild steel.

3. Trailing Arc

The trailing arc is directed in the opposite direction as torch travel.

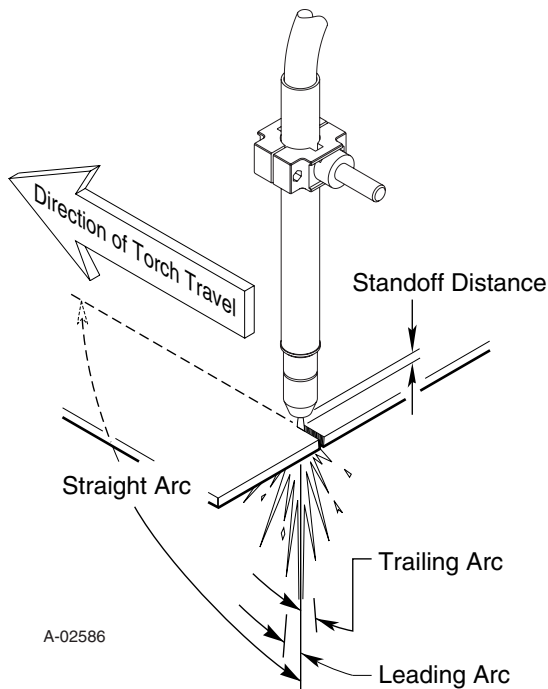

Mechanized Torch Operation

For optimum smooth surface quality, the travel speed should be adjusted so that only the leading edge of the arc column produces the cut. If the travel speed is too slow, a rough cut will be produced as the arc moves from side to side in search of metal for transfer.

Travel speed also affects the bevel angle of a cut. When cutting in a circle or around a corner, slowing down the travel speed will result in a squarer cut. The power source output should be reduced also. Refer to the appropriate Control Module Operating Manual for any Corner Slowdown adjustments that may be required.

Piercing With Machine Torch

To pierce with a machine torch, the arc should be started with the torch positioned as high as possible above the plate while allowing the arc to transfer and pierce. This standoff helps avoid having molten metal blow back onto the front end of the torch.

When operating with a cutting machine, a pierce or dwell time is required. Torch travel should not be enabled until the arc penetrates the bottom of the plate. As motion begins, torch standoff should be reduced to the recommended 1/8 - 1/4 inch (3-6 mm) distance for optimum speed and cut quality. Clean spatter and scale from the shield cup and the tip as soon as possible. Spraying or dipping the shield cup in anti-spatter compound will minimize the amount of scale which adheres to it.

4T.07 Parts Selection for SL100Torch Cutting

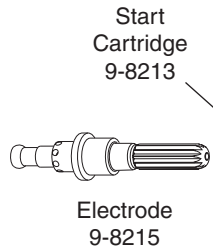
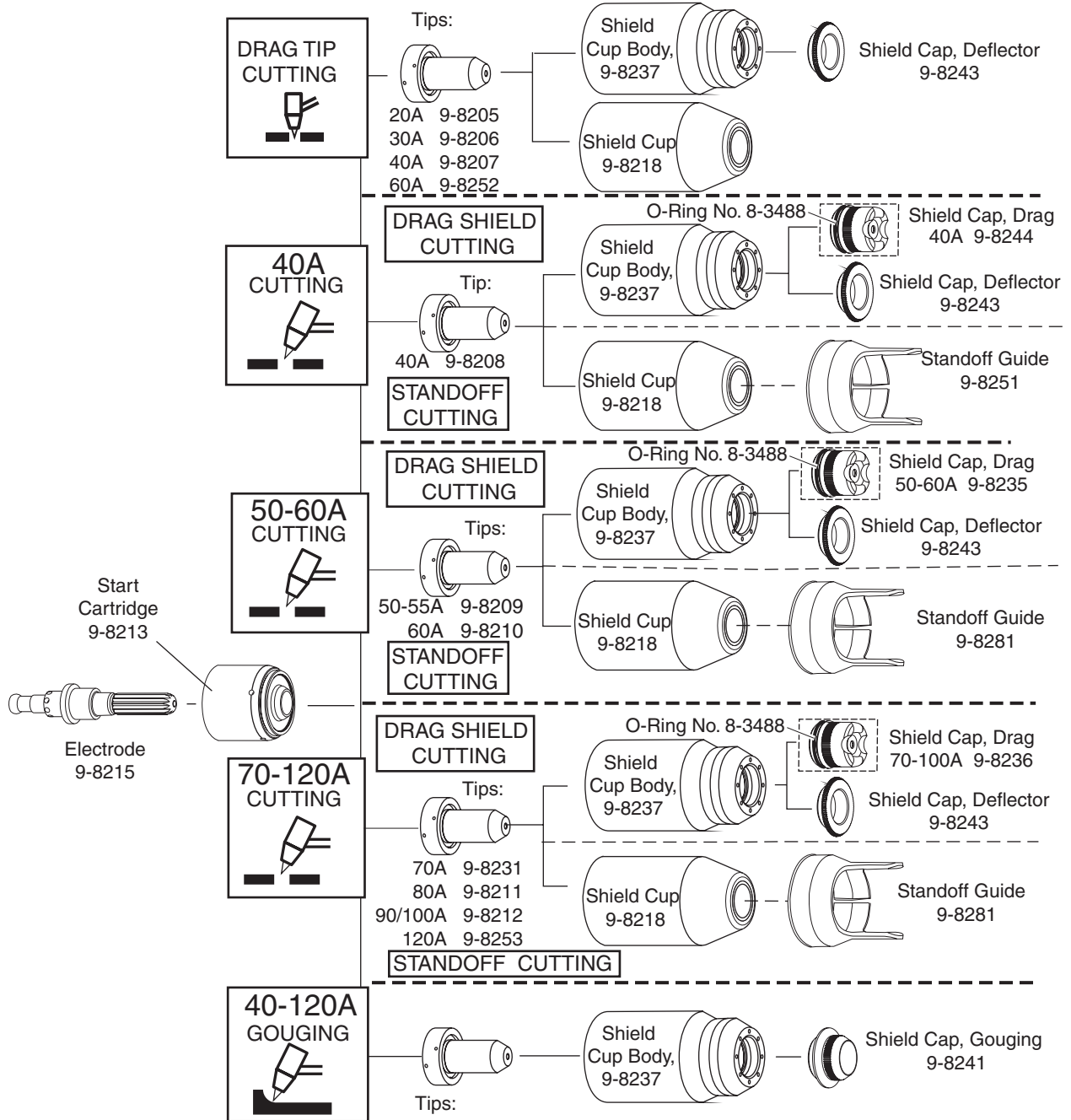

Art # A-08065_AC

NOTE
 CutMaster 52 uses 60A and less
 CutMaster 82 uses 80A and less
 CutMaster 102 uses 100A and less
 CutMaster 152 uses 120A and less

CUTMASTER 40mm

4T.08 Recommended Cutting Speeds for SL100 Torch With Exposed Tip

| Type Torch: SL100 With Exposed Tip | | | | | | | Type Material: Mild Steel | | | | | | | | |
|------------------------------------|------|------------|------------|----------|--------------------|--------|--------------------------------------|-----|------------------|-----|------------|---------|-------------|---------------|-----|
| Type Plasma Gas: Air | | | | | | | Type Secondary Gas: Single Gas Torch | | | | | | | | |
| Thickness | | Tip | Output | Amperage | Speed (Per Minute) | | Standoff | | Plasma Gas Press | | Flow (CFH) | | Pierce | Pierce Height | |
| Inches | mm | (Cat. No.) | Volts(VDC) | (Amps) | Inches | Meters | Inches | mm | psi* | bar | Plasma | Total** | Delay (Sec) | Inches | mm |
| 0.036 | 0.9 | 9-8208 | 104 | 40 | 340 | 8.64 | 0.19 | 4.8 | 65 | 4.5 | 55 | 170 | 0.00 | 0.2 | 5.1 |
| 0.06 | 1.5 | 9-8208 | 108 | 40 | 250 | 6.35 | 0.19 | 4.8 | 65 | 4.5 | 55 | 170 | 0.10 | 0.2 | 5.1 |
| 0.075 | 1.9 | 9-8208 | 108 | 40 | 190 | 4.83 | 0.19 | 4.8 | 65 | 4.5 | 55 | 170 | 0.30 | 0.2 | 5.1 |
| 0.135 | 3.4 | 9-8208 | 110 | 40 | 105 | 2.67 | 0.19 | 4.8 | 65 | 4.5 | 55 | 170 | 0.40 | 0.2 | 5.1 |
| 0.188 | 4.8 | 9-8208 | 113 | 40 | 60 | 1.52 | 0.19 | 4.8 | 65 | 4.5 | 55 | 170 | 0.60 | 0.2 | 5.1 |
| 0.25 | 6.4 | 9-8208 | 111 | 40 | 40 | 1.02 | 0.19 | 4.8 | 65 | 4.5 | 55 | 170 | 1.00 | 0.2 | 5.1 |
| 0.375 | 9.5 | 9-8208 | 124 | 40 | 21 | 0.53 | 0.19 | 4.8 | 65 | 4.5 | 55 | 170 | NR | NR | NR |
| 0.500 | 12.7 | 9-8208 | 123 | 40 | 11 | 0.28 | 0.19 | 4.8 | 65 | 4.5 | 55 | 170 | NR | NR | NR |
| 0.625 | 15.9 | 9-8208 | 137 | 40 | 7 | 0.18 | 0.19 | 4.8 | 65 | 4.5 | 55 | 170 | NR | NR | NR |

| Type Torch: SL100 With Exposed Tip | | | | | | | Type Material: Stainless Steel | | | | | | | | |
|------------------------------------|-----|------------|------------|----------|--------------------|--------|--------------------------------------|-----|------------------|-----|------------|---------|-------------|---------------|-----|
| Type Plasma Gas: Air | | | | | | | Type Secondary Gas: Single Gas Torch | | | | | | | | |
| Thickness | | Tip | Output | Amperage | Speed (Per Minute) | | Standoff | | Plasma Gas Press | | Flow (CFH) | | Pierce | Pierce Height | |
| Inches | mm | (Cat. No.) | Volts(VDC) | (Amps) | Inches | Meters | Inches | mm | psi* | bar | Plasma | Total** | Delay (Sec) | Inches | mm |
| 0.036 | 0.9 | 9-8208 | 103 | 40 | 355 | 9.02 | 0.125 | 3.2 | 65 | 4.5 | 55 | 170 | 0.00 | 0.2 | 5.1 |
| 0.05 | 1.3 | 9-8208 | 98 | 40 | 310 | 7.87 | 0.125 | 3.2 | 65 | 4.5 | 55 | 170 | 0.00 | 0.2 | 5.1 |
| 0.06 | 1.5 | 9-8208 | 98 | 40 | 240 | 6.10 | 0.125 | 3.2 | 65 | 4.5 | 55 | 170 | 0.10 | 0.2 | 5.1 |
| 0.078 | 2.0 | 9-8208 | 100 | 40 | 125 | 3.18 | 0.125 | 3.2 | 65 | 4.5 | 55 | 170 | 0.30 | 0.2 | 5.1 |
| 0.135 | 3.4 | 9-8208 | 120 | 40 | 30 | 0.76 | 0.187 | 4.8 | 65 | 4.5 | 55 | 170 | 0.40 | 0.2 | 5.1 |
| 0.188 | 4.8 | 9-8208 | 124 | 40 | 20 | 0.51 | 0.187 | 4.8 | 65 | 4.5 | 55 | 170 | 0.60 | 0.2 | 5.1 |
| 0.25 | 6.4 | 9-8208 | 122 | 40 | 15 | 0.38 | 0.187 | 4.8 | 65 | 4.5 | 55 | 170 | 1.00 | 0.2 | 5.1 |
| 0.375 | 9.5 | 9-8208 | 126 | 40 | 10 | 0.25 | 0.187 | 4.8 | 65 | 4.5 | 55 | 170 | NR | NR | NR |

| Type Torch: SL100 With Exposed Tip | | | | | | | Type Material: Aluminum | | | | | | | | |
|------------------------------------|-----|------------|------------|----------|--------------------|--------|--------------------------------------|-----|------------------|-----|------------|---------|-------------|---------------|-----|
| Type Plasma Gas: Air | | | | | | | Type Secondary Gas: Single Gas Torch | | | | | | | | |
| Thickness | | Tip | Output | Amperage | Speed (Per Minute) | | Standoff | | Plasma Gas Press | | Flow (CFH) | | Pierce | Pierce Height | |
| Inches | mm | (Cat. No.) | Volts(VDC) | (Amps) | Inches | Meters | Inches | mm | psi* | bar | Plasma | Total** | Delay (Sec) | Inches | mm |
| 0.032 | 0.8 | 9-8208 | 110 | 40 | 440 | 11.18 | 0.187 | 4.8 | 65 | 4.5 | 55 | 170 | 0.00 | 0.2 | 5.1 |
| 0.051 | 1.3 | 9-8208 | 109 | 40 | 350 | 8.89 | 0.187 | 4.8 | 65 | 4.5 | 55 | 170 | 0.10 | 0.2 | 5.1 |
| 0.064 | 1.6 | 9-8208 | 112 | 40 | 250 | 6.35 | 0.187 | 4.8 | 65 | 4.5 | 55 | 170 | 0.10 | 0.2 | 5.1 |
| 0.079 | 2.0 | 9-8208 | 112 | 40 | 200 | 5.08 | 0.19 | 4.8 | 65 | 4.5 | 55 | 170 | 0.30 | 0.2 | 5.1 |
| 0.125 | 3.2 | 9-8208 | 118 | 40 | 100 | 2.54 | 0.19 | 4.8 | 65 | 4.5 | 55 | 170 | 0.40 | 0.2 | 5.1 |
| 0.188 | 4.8 | 9-8208 | 120 | 40 | 98 | 2.49 | 0.187 | 4.8 | 65 | 4.5 | 55 | 170 | 0.60 | 0.2 | 5.1 |
| 0.250 | 6.4 | 9-8208 | 123 | 40 | 50 | 1.27 | 0.187 | 4.8 | 65 | 4.5 | 55 | 170 | 1.00 | 0.2 | 5.1 |
| 0.375 | 9.5 | 9-8208 | 134 | 40 | 16 | 0.41 | 0.187 | 4.8 | 65 | 4.5 | 55 | 170 | NR | NR | NR |

| Type Torch: SL100 With Exposed Tip | | | | | | | Type Material: Mild Steel | | | | | | | | |
|------------------------------------|------|------------|------------|----------|--------------------|--------|--------------------------------------|-----|------------------|-----|------------|---------|-------------|---------------|-----|
| Type Plasma Gas: Air | | | | | | | Type Secondary Gas: Single Gas Torch | | | | | | | | |
| Thickness | | Tip | Output | Amperage | Speed (Per Minute) | | Standoff | | Plasma Gas Press | | Flow (CFH) | | Pierce | Pierce Height | |
| Inches | mm | (Cat. No.) | Volts(VDC) | (Amps) | Inches | Meters | Inches | mm | psi* | bar | Plasma | Total** | Delay (Sec) | Inches | mm |
| 0.060 | 1.5 | 9-8210 | 110 | 60 | 290 | 7.37 | 0.19 | 4.8 | 70 | 4.8 | 90 | 245 | 0.00 | 0.19 | 4.8 |
| 0.075 | 1.9 | 9-8210 | 120 | 60 | 285 | 7.24 | 0.19 | 4.8 | 70 | 4.8 | 90 | 245 | 0.10 | 0.19 | 4.8 |
| 0.120 | 3.0 | 9-8210 | 120 | 60 | 180 | 4.57 | 0.19 | 4.8 | 70 | 4.8 | 90 | 245 | 0.10 | 0.19 | 4.8 |
| 0.135 | 3.4 | 9-8210 | 119 | 60 | 170 | 4.32 | 0.19 | 4.8 | 70 | 4.8 | 90 | 245 | 0.10 | 0.19 | 4.8 |
| 0.188 | 4.8 | 9-8210 | 121 | 60 | 100 | 2.54 | 0.19 | 4.8 | 70 | 4.8 | 90 | 245 | 0.20 | 0.19 | 4.8 |
| 0.250 | 6.4 | 9-8210 | 119 | 60 | 80 | 2.03 | 0.19 | 4.8 | 70 | 4.8 | 90 | 245 | 0.30 | 0.19 | 4.8 |
| 0.375 | 9.5 | 9-8210 | 124 | 60 | 50 | 1.27 | 0.19 | 4.8 | 70 | 4.8 | 90 | 245 | 0.50 | 0.19 | 4.8 |
| 0.500 | 12.7 | 9-8210 | 126 | 60 | 26 | 0.66 | 0.19 | 4.8 | 70 | 4.8 | 90 | 245 | 0.75 | 0.19 | 4.8 |
| 0.625 | 15.9 | 9-8210 | 127 | 60 | 19 | 0.48 | 0.19 | 4.8 | 70 | 4.8 | 90 | 245 | NR | NR | NR |
| 0.750 | 19.1 | 9-8210 | 134 | 60 | 14 | 0.36 | 0.19 | 4.8 | 70 | 4.8 | 90 | 245 | NR | NR | NR |
| 1.000 | 25.4 | 9-8210 | 140 | 60 | 6 | 0.15 | 0.19 | 4.8 | 70 | 4.8 | 90 | 245 | NR | NR | NR |

| Type Torch: SL100 With Exposed Tip | | | | | | | Type Material: Stainless Steel | | | | | | | | |
|------------------------------------|------|------------|------------|----------|--------------------|--------|--------------------------------------|-----|------------------|-----|------------|---------|-------------|---------------|-----|
| Type Plasma Gas: Air | | | | | | | Type Secondary Gas: Single Gas Torch | | | | | | | | |
| Thickness | | Tip | Output | Amperage | Speed (Per Minute) | | Standoff | | Plasma Gas Press | | Flow (CFH) | | Pierce | Pierce Height | |
| Inches | mm | (Cat. No.) | Volts(VDC) | (Amps) | Inches | Meters | Inches | mm | psi* | bar | Plasma | Total** | Delay (Sec) | Inches | mm |
| 0.06 | 1.5 | 9-8210 | 119 | 60 | 350 | 8.91 | 0.19 | 4.8 | 70 | 4.8 | 90 | 245 | 0.00 | 0.20 | 5.1 |
| 0.075 | 1.9 | 9-8210 | 116 | 60 | 300 | 7.64 | 0.19 | 4.8 | 70 | 4.8 | 90 | 245 | 0.10 | 0.20 | 5.1 |
| 0.120 | 3.0 | 9-8210 | 123 | 60 | 150 | 3.82 | 0.19 | 4.8 | 70 | 4.8 | 90 | 245 | 0.10 | 0.20 | 5.1 |
| 0.135 | 3.4 | 9-8210 | 118 | 60 | 125 | 3.18 | 0.19 | 4.8 | 70 | 4.8 | 90 | 245 | 0.10 | 0.20 | 5.1 |
| 0.188 | 4.8 | 9-8210 | 122 | 60 | 90 | 2.29 | 0.19 | 4.8 | 70 | 4.8 | 90 | 245 | 0.20 | 0.20 | 5.1 |
| 0.250 | 6.4 | 9-8210 | 120 | 60 | 65 | 1.65 | 0.19 | 4.8 | 70 | 4.8 | 90 | 245 | 0.30 | 0.20 | 5.1 |
| 0.375 | 9.5 | 9-8210 | 130 | 60 | 30 | 0.76 | 0.19 | 4.8 | 70 | 4.8 | 90 | 245 | 0.50 | 0.20 | 5.1 |
| 0.500 | 12.7 | 9-8210 | 132 | 60 | 21 | 0.53 | 0.19 | 4.8 | 70 | 4.8 | 90 | 245 | 0.75 | 0.20 | 5.1 |
| 0.625 | 15.9 | 9-8210 | 130 | 60 | 15 | 0.38 | 0.19 | 4.8 | 70 | 4.8 | 90 | 245 | NR | NR | NR |
| 0.750 | 19.1 | 9-8210 | 142 | 60 | 12 | 0.31 | 0.25 | 6.4 | 70 | 4.8 | 90 | 245 | NR | NR | NR |

| Type Torch: SL100 With Exposed Tip | | | | | | | Type Material: Aluminum | | | | | | | | |
|------------------------------------|------|------------|------------|----------|--------------------|--------|--------------------------------------|-----|------------------|-----|------------|---------|-------------|---------------|-----|
| Type Plasma Gas: Air | | | | | | | Type Secondary Gas: Single Gas Torch | | | | | | | | |
| Thickness | | Tip | Output | Amperage | Speed (Per Minute) | | Standoff | | Plasma Gas Press | | Flow (CFH) | | Pierce | Pierce Height | |
| Inches | mm | (Cat. No.) | Volts(VDC) | (Amps) | Inches | Meters | Inches | mm | psi* | bar | Plasma | Total** | Delay (Sec) | Inches | mm |
| 0.060 | 1.5 | 9-8210 | 110 | 60 | 440 | 11.18 | 0.25 | 6.4 | 70 | 4.8 | 90 | 245 | 0.00 | 0.25 | 6.4 |
| 0.075 | 1.9 | 9-8210 | 110 | 60 | 440 | 11.18 | 0.25 | 6.4 | 70 | 4.8 | 90 | 245 | 0.10 | 0.25 | 6.4 |
| 0.120 | 3.0 | 9-8210 | 116 | 60 | 250 | 6.35 | 0.25 | 6.4 | 70 | 4.8 | 90 | 245 | 0.10 | 0.25 | 6.4 |
| 0.188 | 3.4 | 9-8210 | 116 | 60 | 170 | 4.32 | 0.25 | 6.4 | 70 | 4.8 | 90 | 245 | 0.20 | 0.25 | 6.4 |
| 0.250 | 6.4 | 9-8210 | 132 | 60 | 85 | 2.16 | 0.25 | 6.4 | 70 | 4.8 | 90 | 245 | 0.30 | 0.25 | 6.4 |
| 0.375 | 9.5 | 9-8210 | 140 | 60 | 45 | 1.14 | 0.25 | 6.4 | 70 | 4.8 | 90 | 245 | 0.50 | 0.25 | 6.4 |
| 0.500 | 12.7 | 9-8210 | 143 | 60 | 30 | 0.76 | 0.25 | 6.4 | 70 | 4.8 | 90 | 245 | 0.80 | 0.25 | 6.4 |
| 0.625 | 15.9 | 9-8210 | 145 | 60 | 20 | 0.51 | 0.25 | 6.4 | 70 | 4.8 | 90 | 245 | NR | NR | NR |
| 0.750 | 19.1 | 9-8210 | 145 | 60 | 18 | 0.46 | 0.25 | 6.4 | 70 | 4.8 | 90 | 245 | NR | NR | NR |

CUTMASTER 40mm

| Type Torch: SL100 With Exposed Tip | | | | | | | Type Material: Mild Steel | | | | | | | | |
|------------------------------------|------|------------|------------|----------|--------------------|--------|--------------------------------------|-----|------------------|-----|------------|---------|-------------|---------------|-----|
| Type Plasma Gas: Air | | | | | | | Type Secondary Gas: Single Gas Torch | | | | | | | | |
| Thickness | | Tip | Output | Amperage | Speed (Per Minute) | | Standoff | | Plasma Gas Press | | Flow (CFH) | | Pierce | Pierce Height | |
| Inches | mm | (Cat. No.) | Volts(VDC) | (Amps) | Inches | Meters | Inches | mm | psi* | bar | Plasma | Total** | Delay (Sec) | Inches | mm |
| 0.060 | 1.5 | 9-8211 | 113 | 80 | 320 | 8.13 | 0.19 | 4.8 | 65 | 4.5 | 115 | 340 | 0.00 | 0.19 | 4.8 |
| 0.120 | 3.0 | 9-8211 | 113 | 80 | 230 | 5.84 | 0.19 | 4.8 | 65 | 4.5 | 115 | 340 | 0.10 | 0.19 | 4.8 |
| 0.135 | 3.4 | 9-8211 | 115 | 80 | 180 | 4.57 | 0.19 | 4.8 | 65 | 4.5 | 115 | 340 | 0.10 | 0.19 | 4.8 |
| 0.188 | 4.8 | 9-8211 | 114 | 80 | 140 | 3.56 | 0.19 | 4.8 | 65 | 4.5 | 115 | 340 | 0.20 | 0.19 | 4.8 |
| 0.250 | 6.4 | 9-8211 | 114 | 80 | 100 | 2.54 | 0.19 | 4.8 | 65 | 4.5 | 115 | 340 | 0.30 | 0.19 | 4.8 |
| 0.375 | 9.5 | 9-8211 | 117 | 80 | 42 | 1.07 | 0.19 | 4.8 | 65 | 4.5 | 115 | 340 | 0.40 | 0.19 | 4.8 |
| 0.500 | 12.7 | 9-8211 | 120 | 80 | 33 | 0.84 | 0.19 | 4.8 | 65 | 4.5 | 115 | 340 | 0.60 | 0.19 | 4.8 |
| 0.625 | 15.9 | 9-8211 | 133 | 80 | 22 | 0.56 | 0.19 | 4.8 | 65 | 4.5 | 115 | 340 | 0.75 | 0.19 | 4.8 |
| 0.750 | 19.1 | 9-8211 | 128 | 80 | 18 | 0.46 | 0.19 | 4.8 | 65 | 4.5 | 115 | 340 | NR | NR | NR |
| 0.875 | 22.2 | 9-8211 | 133 | 80 | 10 | 0.25 | 0.19 | 4.8 | 65 | 4.5 | 115 | 340 | NR | NR | NR |
| 1.000 | 25.4 | 9-8211 | 132 | 80 | 9 | 0.23 | 0.19 | 4.8 | 65 | 4.5 | 115 | 340 | NR | NR | NR |

| Type Torch: SL100 With Exposed Tip | | | | | | | Type Material: Stainless Steel | | | | | | | | |
|------------------------------------|------|------------|------------|----------|--------------------|--------|--------------------------------------|-----|------------------|-----|------------|---------|-------------|---------------|-----|
| Type Plasma Gas: Air | | | | | | | Type Secondary Gas: Single Gas Torch | | | | | | | | |
| Thickness | | Tip | Output | Amperage | Speed (Per Minute) | | Standoff | | Plasma Gas Press | | Flow (CFH) | | Pierce | Pierce Height | |
| Inches | mm | (Cat. No.) | Volts(VDC) | (Amps) | Inches | Meters | Inches | mm | psi* | bar | Plasma | Total** | Delay (Sec) | Inches | mm |
| 0.060 | 1.5 | 9-8211 | 120 | 80 | 340 | 8.64 | 0.25 | 6.4 | 65 | 4.5 | 115 | 340 | 0.00 | 0.25 | 6.4 |
| 0.120 | 3.0 | 9-8211 | 120 | 80 | 300 | 7.62 | 0.25 | 6.4 | 65 | 4.5 | 115 | 340 | 0.10 | 0.25 | 6.4 |
| 0.135 | 3.4 | 9-8211 | 120 | 80 | 280 | 7.11 | 0.25 | 6.4 | 65 | 4.5 | 115 | 340 | 0.10 | 0.25 | 6.4 |
| 0.188 | 4.8 | 9-8211 | 120 | 80 | 140 | 3.56 | 0.25 | 6.4 | 65 | 4.5 | 115 | 340 | 0.20 | 0.25 | 6.4 |
| 0.250 | 6.4 | 9-8211 | 120 | 80 | 100 | 2.54 | 0.25 | 6.4 | 65 | 4.5 | 115 | 340 | 0.30 | 0.25 | 6.4 |
| 0.375 | 9.5 | 9-8211 | 126 | 80 | 50 | 1.27 | 0.25 | 6.4 | 65 | 4.5 | 115 | 340 | 0.40 | 0.25 | 6.4 |
| 0.500 | 12.7 | 9-8211 | 129 | 80 | 28 | 0.71 | 0.25 | 6.4 | 65 | 4.5 | 115 | 340 | 0.80 | 0.25 | 6.4 |
| 0.625 | 15.9 | 9-8211 | 135 | 80 | 20 | 0.51 | 0.25 | 6.4 | 65 | 4.5 | 115 | 340 | 1.00 | 0.25 | 6.4 |
| 0.750 | 19.1 | 9-8211 | 143 | 80 | 10 | 0.25 | 0.25 | 6.4 | 65 | 4.5 | 115 | 340 | NR | NR | NR |
| 0.875 | 22.2 | 9-8211 | 143 | 80 | 9 | 0.23 | 0.25 | 6.4 | 65 | 4.5 | 115 | 340 | NR | NR | NR |
| 1.000 | 25.4 | 9-8211 | 146 | 80 | 8 | 0.20 | 0.25 | 6.4 | 65 | 4.5 | 115 | 340 | NR | NR | NR |

| Type Torch: SL100 with Exposed Tip | | | | | | | Type Material: Aluminum | | | | | | | | |
|------------------------------------|------|------------|------------|----------|--------------------|--------|--------------------------------------|-----|------------------|-----|------------|---------|-------------|---------------|-----|
| Type Plasma Gas: Air | | | | | | | Type Secondary Gas: Single Gas Torch | | | | | | | | |
| Thickness | | Tip | Output | Amperage | Speed (Per Minute) | | Standoff | | Plasma Gas Press | | Flow (CFH) | | Pierce | Pierce Height | |
| Inches | mm | (Cat. No.) | Volts(VDC) | (Amps) | Inches | Meters | Inches | mm | psi* | bar | Plasma | Total** | Delay (Sec) | Inches | mm |
| 0.06 | 1.5 | 9-8211 | 120 | 80 | 350 | 8.89 | 0.25 | 6.4 | 65 | 4.5 | 115 | 340 | 0.00 | 0.25 | 6.4 |
| 0.12 | 3.0 | 9-8211 | 124 | 80 | 300 | 7.62 | 0.25 | 6.4 | 65 | 4.5 | 115 | 340 | 0.10 | 0.25 | 6.4 |
| 0.188 | 4.8 | 9-8211 | 124 | 80 | 180 | 4.57 | 0.25 | 6.4 | 65 | 4.5 | 115 | 340 | 0.20 | 0.25 | 6.4 |
| 0.250 | 6.4 | 9-8211 | 128 | 80 | 110 | 2.79 | 0.25 | 6.4 | 65 | 4.5 | 115 | 340 | 0.30 | 0.25 | 6.4 |
| 0.375 | 9.5 | 9-8211 | 136 | 80 | 55 | 1.40 | 0.25 | 6.4 | 65 | 4.5 | 115 | 340 | 0.40 | 0.25 | 6.4 |
| 0.500 | 12.7 | 9-8211 | 139 | 80 | 38 | 0.97 | 0.25 | 6.4 | 65 | 4.5 | 115 | 340 | 0.60 | 0.25 | 6.4 |
| 0.625 | 15.9 | 9-8211 | 142 | 80 | 26 | 0.66 | 0.25 | 6.4 | 65 | 4.5 | 115 | 340 | 0.75 | 0.25 | 6.4 |
| 0.750 | 19.1 | 9-8211 | 145 | 80 | 24 | 0.61 | 0.25 | 6.4 | 65 | 4.5 | 115 | 340 | NR | NR | NR |
| 0.875 | 22.2 | 9-8211 | 153 | 80 | 10 | 0.25 | 0.25 | 6.4 | 65 | 4.5 | 115 | 340 | NR | NR | NR |
| 1.000 | 25.4 | 9-8211 | 162 | 80 | 6 | 0.15 | 0.25 | 6.4 | 65 | 4.5 | 115 | 340 | NR | NR | NR |

| Type Torch: SL100 With Exposed Tip | | | | | | | Type Material: Mild Steel | | | | | | | | |
|------------------------------------|------|------------|------------|----------|--------------------|--------|--------------------------------------|-----|------------------|-----|------------|---------|-------------|---------------|-----|
| Type Plasma Gas: Air | | | | | | | Type Secondary Gas: Single Gas Torch | | | | | | | | |
| Thickness | | Tip | Output | Amperage | Speed (Per Minute) | | Standoff | | Plasma Gas Press | | Flow (CFH) | | Pierce | Pierce Height | |
| Inches | mm | (Cat. No.) | Volts(VDC) | (Amps) | Inches | Meters | Inches | mm | psi* | bar | Plasma | Total** | Delay (Sec) | Inches | mm |
| 0.250 | 6.4 | 9-8212 | 110 | 100 | 105 | 2.65 | 0.190 | 4.8 | 75 | 5.2 | 130 | 390 | 0.4 | 0.200 | 5.1 |
| 0.375 | 9.5 | 9-8212 | 117 | 100 | 70 | 1.75 | 0.190 | 4.8 | 75 | 5.2 | 130 | 390 | 0.5 | 0.200 | 5.1 |
| 0.500 | 12.7 | 9-8212 | 120 | 100 | 50 | 1.25 | 0.190 | 4.8 | 75 | 5.2 | 130 | 390 | 0.6 | 0.200 | 5.1 |
| 0.625 | 15.9 | 9-8212 | 125 | 100 | 35 | 0.90 | 0.190 | 4.8 | 75 | 5.2 | 130 | 390 | 1.0 | 0.200 | 5.1 |
| 0.750 | 19.0 | 9-8212 | 131 | 100 | 18 | 0.45 | 0.190 | 4.8 | 75 | 5.2 | 130 | 390 | 2.0 | 0.250 | 6.4 |
| 1.000 | 25.4 | 9-8212 | 135 | 100 | 10 | 0.25 | 0.190 | 4.8 | 75 | 5.2 | 130 | 390 | NR | NR | NR |

| Type Torch: SL100 With Exposed Tip | | | | | | | Type Material: Stainless Steel | | | | | | | | |
|------------------------------------|------|------------|------------|----------|--------------------|--------|--------------------------------------|-----|------------------|-----|------------|---------|-------------|---------------|-----|
| Type Plasma Gas: Air | | | | | | | Type Secondary Gas: Single Gas Torch | | | | | | | | |
| Thickness | | Tip | Output | Amperage | Speed (Per Minute) | | Standoff | | Plasma Gas Press | | Flow (CFH) | | Pierce | Pierce Height | |
| Inches | mm | (Cat. No.) | Volts(VDC) | (Amps) | Inches | Meters | Inches | mm | psi* | bar | Plasma | Total** | Delay (Sec) | Inches | mm |
| 0.250 | 6.4 | 9-8212 | 118 | 100 | 90 | 2.30 | 0.190 | 4.8 | 75 | 5.2 | 130 | 390 | 0.5 | 0.250 | 6.4 |
| 0.375 | 9.5 | 9-8212 | 122 | 100 | 55 | 1.40 | 0.190 | 4.8 | 75 | 5.2 | 130 | 390 | 0.8 | 0.250 | 6.4 |
| 0.500 | 12.7 | 9-8212 | 126 | 100 | 30 | 0.75 | 0.190 | 4.8 | 75 | 5.2 | 130 | 390 | 1.0 | 0.250 | 6.4 |
| 0.625 | 15.9 | 9-8212 | 133 | 100 | 20 | 0.50 | 0.190 | 4.8 | 75 | 5.2 | 130 | 390 | 1.5 | 0.250 | 6.4 |
| 0.750 | 19.0 | 9-8212 | 138 | 100 | 15 | 0.40 | 0.190 | 4.8 | 75 | 5.2 | 130 | 390 | NR | NR | NR |
| 1.000 | 25.4 | 9-8212 | 139 | 100 | 10 | 0.25 | 0.190 | 4.8 | 75 | 5.2 | 130 | 390 | NR | NR | NR |

| Type Torch: SL100 with Exposed Tip | | | | | | | Type Material: Aluminum | | | | | | | | |
|------------------------------------|------|------------|------------|----------|--------------------|--------|--------------------------------------|-----|------------------|-----|------------|---------|-------------|---------------|-----|
| Type Plasma Gas: Air | | | | | | | Type Secondary Gas: Single Gas Torch | | | | | | | | |
| Thickness | | Tip | Output | Amperage | Speed (Per Minute) | | Standoff | | Plasma Gas Press | | Flow (CFH) | | Pierce | Pierce Height | |
| Inches | mm | (Cat. No.) | Volts(VDC) | (Amps) | Inches | Meters | Inches | mm | psi* | bar | Plasma | Total** | Delay (Sec) | Inches | mm |
| 0.250 | 6.4 | 9-8212 | 108 | 100 | 120 | 3.05 | 0.190 | 4.8 | 65 | 4.5 | 120 | 360 | 0.2 | 0.225 | 5.7 |
| 0.375 | 9.5 | 9-8212 | 117 | 100 | 65 | 1.65 | 0.190 | 4.8 | 65 | 4.5 | 120 | 360 | 0.4 | 0.225 | 5.7 |
| 0.500 | 12.7 | 9-8212 | 120 | 100 | 45 | 1.15 | 0.190 | 4.8 | 65 | 4.5 | 120 | 360 | 0.5 | 0.225 | 5.7 |
| 0.625 | 15.9 | 9-8212 | 125 | 100 | 30 | 0.75 | 0.190 | 4.8 | 65 | 4.5 | 120 | 360 | 0.8 | 0.225 | 5.7 |
| 0.750 | 19.0 | 9-8212 | 131 | 100 | 25 | 0.65 | 0.190 | 4.8 | 65 | 4.5 | 120 | 360 | 1.0 | 0.225 | 5.7 |
| 1.000 | 25.4 | 9-8212 | 140 | 100 | 10 | 0.25 | 0.190 | 4.8 | 65 | 4.5 | 120 | 360 | NR | NR | NR |

CUTMASTER 40mm

| Type Torch: SL100 With Exposed Tip | | | | | | | Type Material: Mild Steel | | | | | | | | |
|------------------------------------|------|------------|------------|----------|--------------------|--------|--------------------------------------|-----|------------------|-----|------------|---------|-------------|---------------|-----|
| Type Plasma Gas: Air | | | | | | | Type Secondary Gas: Single Gas Torch | | | | | | | | |
| Thickness | | Tip | Output | Amperage | Speed (Per Minute) | | Standoff | | Plasma Gas Press | | Flow (CFH) | | Pierce | Pierce Height | |
| Inches | mm | (Cat. No.) | Volts(VDC) | (Amps) | Inches | Meters | Inches | mm | psi* | bar | Plasma | Total** | Delay (Sec) | Inches | mm |
| 0.250 | 6.4 | 9-8253 | 138 | 120 | 150 | 3.81 | 0.19 | 4.8 | 75 | 5.2 | 180 | 360 | 0.10 | 0.25 | 6.4 |
| 0.375 | 9.5 | 9-8253 | 140 | 120 | 85 | 2.16 | 0.19 | 4.8 | 75 | 5.2 | 180 | 360 | 0.30 | 0.25 | 6.4 |
| 0.500 | 12.7 | 9-8253 | 144 | 120 | 70 | 1.78 | 0.19 | 4.8 | 75 | 5.2 | 180 | 360 | 0.50 | 0.25 | 6.4 |
| 0.625 | 15.9 | 9-8253 | 152 | 120 | 45 | 1.14 | 0.19 | 4.8 | 75 | 5.2 | 180 | 360 | 0.70 | 0.25 | 6.4 |
| 0.750 | 19.0 | 9-8253 | 155 | 120 | 30 | 0.76 | 0.19 | 4.8 | 75 | 5.2 | 180 | 360 | 0.90 | 0.25 | 6.4 |
| 0.875 | 22.2 | 9-8253 | 160 | 120 | 25 | 0.64 | 0.25 | 6.4 | 75 | 5.2 | 180 | 360 | NR | NR | NR |
| 1.000 | 25.4 | 9-8253 | 164 | 120 | 20 | 0.51 | 0.25 | 6.4 | 75 | 5.2 | 180 | 360 | NR | NR | NR |
| 1.250 | 31.8 | 9-8253 | 170 | 120 | 12 | 0.30 | 0.25 | 6.4 | 75 | 5.2 | 180 | 360 | NR | NR | NR |
| 1.500 | 38.1 | 9-8253 | 180 | 120 | 8 | 0.20 | 0.25 | 6.4 | 75 | 5.2 | 180 | 360 | NR | NR | NR |

| Type Torch: SL100 With Exposed Tip | | | | | | | Type Material: Stainless Steel | | | | | | | | |
|------------------------------------|------|------------|------------|----------|--------------------|--------|--------------------------------------|-----|------------------|-----|------------|---------|-------------|---------------|-----|
| Type Plasma Gas: Air | | | | | | | Type Secondary Gas: Single Gas Torch | | | | | | | | |
| Thickness | | Tip | Output | Amperage | Speed (Per Minute) | | Standoff | | Plasma Gas Press | | Flow (CFH) | | Pierce | Pierce Height | |
| Inches | mm | (Cat. No.) | Volts(VDC) | (Amps) | Inches | Meters | Inches | mm | psi* | bar | Plasma | Total** | Delay (Sec) | Inches | mm |
| 0.250 | 6.4 | 9-8253 | 135 | 120 | 180 | 4.57 | 0.19 | 4.8 | 75 | 5.2 | 180 | 360 | 0.20 | 0.25 | 6.4 |
| 0.375 | 9.5 | 9-8253 | 144 | 120 | 100 | 2.54 | 0.19 | 4.8 | 75 | 5.2 | 180 | 360 | 0.40 | 0.25 | 6.4 |
| 0.500 | 12.7 | 9-8253 | 146 | 120 | 60 | 1.52 | 0.19 | 4.8 | 75 | 5.2 | 180 | 360 | 0.80 | 0.25 | 6.4 |
| 0.625 | 15.9 | 9-8253 | 155 | 120 | 40 | 1.02 | 0.25 | 6.4 | 75 | 5.2 | 180 | 360 | 1.20 | 0.28 | 7.0 |
| 0.750 | 19.0 | 9-8253 | 164 | 120 | 26 | 0.66 | 0.25 | 6.4 | 75 | 5.2 | 180 | 360 | NR | NR | NR |
| 1.000 | 25.4 | 9-8253 | 164 | 120 | 18 | 0.46 | 0.25 | 6.4 | 75 | 5.2 | 180 | 360 | NR | NR | NR |
| 1.250 | 31.8 | 9-8253 | 170 | 120 | 9 | 0.23 | 0.25 | 6.4 | 75 | 5.2 | 180 | 360 | NR | NR | NR |

| Type Torch: SL100 with Exposed Tip | | | | | | | Type Material: Aluminum | | | | | | | | |
|------------------------------------|------|------------|------------|----------|--------------------|--------|--------------------------------------|-----|------------------|-----|------------|---------|-------------|---------------|-----|
| Type Plasma Gas: Air | | | | | | | Type Secondary Gas: Single Gas Torch | | | | | | | | |
| Thickness | | Tip | Output | Amperage | Speed (Per Minute) | | Standoff | | Plasma Gas Press | | Flow (CFH) | | Pierce | Pierce Height | |
| Inches | mm | (Cat. No.) | Volts(VDC) | (Amps) | Inches | Meters | Inches | mm | psi* | bar | Plasma | Total** | Delay (Sec) | Inches | mm |
| 0.250 | 6.4 | 9-8253 | 142 | 120 | 190 | 4.83 | 0.19 | 4.8 | 75 | 5.2 | 180 | 360 | 0.30 | 0.25 | 6.4 |
| 0.375 | 9.5 | 9-8253 | 145 | 120 | 120 | 3.05 | 0.19 | 4.8 | 75 | 5.2 | 180 | 360 | 0.50 | 0.25 | 6.4 |
| 0.500 | 12.7 | 9-8253 | 151 | 120 | 70 | 1.78 | 0.19 | 4.8 | 75 | 5.2 | 180 | 360 | 0.80 | 0.25 | 6.4 |
| 0.625 | 15.9 | 9-8253 | 162 | 120 | 50 | 1.27 | 0.25 | 6.4 | 75 | 5.2 | 180 | 360 | 1.00 | 0.28 | 7.0 |
| 0.750 | 19.0 | 9-8253 | 164 | 120 | 34 | 0.86 | 0.25 | 6.4 | 75 | 5.2 | 180 | 360 | NR | NR | NR |
| 1.000 | 25.4 | 9-8253 | 170 | 120 | 20 | 0.51 | 0.25 | 6.4 | 75 | 5.2 | 180 | 360 | NR | NR | NR |

NOTES

* Gas pressure shown is for torches with leads up to 25' / 7.6 m long. For 50' / 15.2 m leads, refer to section 4.02 "Operating Pressure".

** Total flow rate includes plasma and secondary gas flow.

4T.09 Recommended Cutting Speeds for SL100 Torch With Shielded Tip

| Type Torch: SL100 With Shielded Tip | | | | | | | Type Material: Mild Steel | | | | | | | | |
|-------------------------------------|------|------------|-------------|----------|--------------------|--------|--------------------------------------|-----|------------------|-----|------------|---------|-------------|---------------|-----|
| Type Plasma Gas: Air | | | | | | | Type Secondary Gas: Single Gas Torch | | | | | | | | |
| Thickness | | Tip | Output | Amperage | Speed (Per Minute) | | Standoff | | Plasma Gas Press | | Flow (CFH) | | Pierce | Pierce Height | |
| Inches | mm | (Cat. No.) | Volts (VDC) | (Amps) | Inches | Meters | Inches | mm | psi* | bar | Plasma | Total** | Delay (Sec) | Inches | mm |
| 0.036 | 0.9 | 9-8208 | 114 | 40 | 170 | 4.32 | 0.19 | 4.8 | 65 | 4.5 | 55 | 170 | 0.00 | 0.2 | 5.1 |
| 0.06 | 1.5 | 9-8208 | 120 | 40 | 90 | 2.29 | 0.19 | 4.8 | 65 | 4.5 | 55 | 170 | 0.10 | 0.2 | 5.1 |
| 0.075 | 1.9 | 9-8208 | 121 | 40 | 80 | 2.03 | 0.19 | 4.8 | 65 | 4.5 | 55 | 170 | 0.30 | 0.2 | 5.1 |
| 0.135 | 3.4 | 9-8208 | 122 | 40 | 75 | 1.91 | 0.19 | 4.8 | 65 | 4.5 | 55 | 170 | 0.40 | 0.2 | 5.1 |
| 0.188 | 4.8 | 9-8208 | 123 | 40 | 30 | 0.76 | 0.19 | 4.8 | 65 | 4.5 | 55 | 170 | 0.60 | 0.2 | 5.1 |
| 0.25 | 6.4 | 9-8208 | 125 | 40 | 25 | 0.64 | 0.19 | 4.8 | 65 | 4.5 | 55 | 170 | 1.00 | 0.2 | 5.1 |
| 0.375 | 9.5 | 9-8208 | 138 | 40 | 11 | 0.28 | 0.19 | 4.8 | 65 | 4.5 | 55 | 170 | NR | NR | NR |
| 0.500 | 12.7 | 9-8208 | 142 | 40 | 7 | 0.18 | 0.19 | 4.8 | 65 | 4.5 | 55 | 170 | NR | NR | NR |
| 0.625 | 15.9 | 9-8208 | 152 | 40 | 3 | 0.08 | 0.19 | 4.8 | 65 | 4.5 | 55 | 170 | NR | NR | NR |

| Type Torch: SL100 With Shielded Tip | | | | | | | Type Material: Stainless Steel | | | | | | | | |
|-------------------------------------|-----|------------|------------|----------|--------------------|--------|--------------------------------------|-----|------------------|-----|------------|---------|-------------|---------------|-----|
| Type Plasma Gas: Air | | | | | | | Type Secondary Gas: Single Gas Torch | | | | | | | | |
| Thickness | | Tip | Output | Amperage | Speed (Per Minute) | | Standoff | | Plasma Gas Press | | Flow (CFH) | | Pierce | Pierce Height | |
| Inches | mm | (Cat. No.) | Volts(VDC) | (Amps) | Inches | Meters | Inches | mm | psi* | bar | Plasma | Total** | Delay (Sec) | Inches | mm |
| 0.036 | 0.9 | 9-8208 | 109 | 40 | 180 | 4.57 | 0.125 | 3.2 | 65 | 4.5 | 55 | 170 | 0.00 | 0.2 | 5.1 |
| 0.05 | 1.3 | 9-8208 | 105 | 40 | 165 | 4.19 | 0.125 | 3.2 | 65 | 4.5 | 55 | 170 | 0.00 | 0.2 | 5.1 |
| 0.06 | 1.5 | 9-8208 | 115 | 40 | 120 | 3.05 | 0.125 | 3.2 | 65 | 4.5 | 55 | 170 | 0.10 | 0.2 | 5.1 |
| 0.078 | 2.0 | 9-8208 | 120 | 40 | 65 | 1.65 | 0.187 | 4.8 | 65 | 4.5 | 55 | 170 | 0.30 | 0.2 | 5.1 |
| 0.135 | 3.4 | 9-8208 | 125 | 40 | 25 | 0.64 | 0.187 | 4.8 | 65 | 4.5 | 55 | 170 | 0.40 | 0.2 | 5.1 |
| 0.188 | 4.8 | 9-8208 | 132 | 40 | 20 | 0.51 | 0.187 | 4.8 | 65 | 4.5 | 55 | 170 | 0.60 | 0.2 | 5.1 |
| 0.25 | 6.4 | 9-8208 | 130 | 40 | 15 | 0.38 | 0.187 | 4.8 | 65 | 4.5 | 55 | 170 | 1.00 | 0.2 | 5.1 |
| 0.375 | 9.5 | 9-8208 | 130 | 40 | 10 | 0.25 | 0.187 | 4.8 | 65 | 4.5 | 55 | 170 | NR | NR | NR |

| Type Torch: SL100 With Shielded Tip | | | | | | | Type Material: Aluminum | | | | | | | | |
|-------------------------------------|-----|------------|------------|----------|--------------------|--------|--------------------------------------|-----|------------------|-----|------------|---------|-------------|---------------|-----|
| Type Plasma Gas: Air | | | | | | | Type Secondary Gas: Single Gas Torch | | | | | | | | |
| Thickness | | Tip | Output | Amperage | Speed (Per Minute) | | Standoff | | Plasma Gas Press | | Flow (CFH) | | Pierce | Pierce Height | |
| Inches | mm | (Cat. No.) | Volts(VDC) | (Amps) | Inches | Meters | Inches | mm | psi* | bar | Plasma | Total** | Delay (Sec) | Inches | mm |
| 0.032 | 0.8 | 9-8208 | 116 | 40 | 220 | 5.59 | 0.187 | 4.8 | 65 | 4.5 | 55 | 170 | 0.00 | 0.2 | 5.1 |
| 0.051 | 1.3 | 9-8208 | 116 | 40 | 210 | 5.33 | 0.187 | 4.8 | 65 | 4.5 | 55 | 170 | 0.00 | 0.2 | 5.1 |
| 0.064 | 1.6 | 9-8208 | 118 | 40 | 180 | 4.57 | 0.187 | 4.8 | 65 | 4.5 | 55 | 170 | 0.10 | 0.2 | 5.1 |
| 0.079 | 2.0 | 9-8208 | 116 | 40 | 150 | 3.81 | 0.19 | 4.8 | 65 | 4.5 | 55 | 170 | 0.30 | 0.2 | 5.1 |
| 0.125 | 3.2 | 9-8208 | 130 | 40 | 75 | 1.91 | 0.19 | 4.8 | 65 | 4.5 | 55 | 170 | 0.40 | 0.2 | 5.1 |
| 0.188 | 4.8 | 9-8208 | 132 | 40 | 60 | 1.52 | 0.187 | 4.8 | 65 | 4.5 | 55 | 170 | 0.60 | 0.2 | 5.1 |
| 0.250 | 6.4 | 9-8208 | 134 | 40 | 28 | 0.71 | 0.187 | 4.8 | 65 | 4.5 | 55 | 170 | 1.00 | 0.2 | 5.1 |
| 0.375 | 9.5 | 9-8208 | 143 | 40 | 11 | 0.28 | 0.187 | 4.8 | 65 | 4.5 | 55 | 170 | NR | NR | NR |

CUTMASTER 40mm

| Type Torch: SL100 With Shielded Tip | | | | | | | Type Material: Mild Steel | | | | | | | | |
|-------------------------------------|------|------------|------------|----------|--------------------|--------|--------------------------------------|-----|------------------|-----|------------|---------|-------------|---------------|-----|
| Type Plasma Gas: Air | | | | | | | Type Secondary Gas: Single Gas Torch | | | | | | | | |
| Thickness | | Tip | Output | Amperage | Speed (Per Minute) | | Standoff | | Plasma Gas Press | | Flow (CFH) | | Pierce | Pierce Height | |
| Inches | mm | (Cat. No.) | Volts(VDC) | (Amps) | Inches | Meters | Inches | mm | psi* | bar | Plasma | Total** | Delay (Sec) | Inches | mm |
| 0.060 | 1.5 | 9-8210 | 124 | 60 | 250 | 6.35 | 0.19 | 4.8 | 70 | 4.8 | 90 | 245 | 0.00 | 0.2 | 5.1 |
| 0.075 | 1.9 | 9-8210 | 126 | 60 | 237 | 6.02 | 0.19 | 4.8 | 70 | 4.8 | 90 | 245 | 0.10 | 0.2 | 5.1 |
| 0.120 | 3.0 | 9-8210 | 126 | 60 | 230 | 5.84 | 0.19 | 4.8 | 70 | 4.8 | 90 | 245 | 0.10 | 0.2 | 5.1 |
| 0.135 | 3.4 | 9-8210 | 128 | 60 | 142 | 3.61 | 0.19 | 4.8 | 70 | 4.8 | 90 | 245 | 0.10 | 0.2 | 5.1 |
| 0.188 | 4.8 | 9-8210 | 128 | 60 | 125 | 3.18 | 0.19 | 4.8 | 70 | 4.8 | 90 | 245 | 0.20 | 0.2 | 5.1 |
| 0.250 | 6.4 | 9-8210 | 123 | 60 | 80 | 2.03 | 0.19 | 4.8 | 70 | 4.8 | 90 | 245 | 0.30 | 0.2 | 5.1 |
| 0.375 | 9.5 | 9-8210 | 132 | 60 | 34 | 0.86 | 0.19 | 4.8 | 70 | 4.8 | 90 | 245 | 0.50 | 0.2 | 5.1 |
| 0.500 | 12.7 | 9-8210 | 137 | 60 | 23 | 0.58 | 0.19 | 4.8 | 70 | 4.8 | 90 | 245 | 0.75 | 0.2 | 5.1 |
| 0.625 | 15.9 | 9-8210 | 139 | 60 | 14 | 0.36 | 0.19 | 4.8 | 70 | 4.8 | 90 | 245 | NR | NR | NR |
| 0.750 | 19.1 | 9-8210 | 145 | 60 | 14 | 0.36 | 0.19 | 4.8 | 70 | 4.8 | 90 | 245 | NR | NR | NR |
| 1.000 | 25.4 | 9-8210 | 156 | 60 | 4 | 0.10 | 0.19 | 4.8 | 70 | 4.8 | 90 | 245 | NR | NR | NR |

| Type Torch: SL100 With Shielded Tip | | | | | | | Type Material: Stainless Steel | | | | | | | | |
|-------------------------------------|------|------------|------------|----------|--------------------|--------|--------------------------------------|-----|------------------|-----|------------|---------|-------------|---------------|-----|
| Type Plasma Gas: Air | | | | | | | Type Secondary Gas: Single Gas Torch | | | | | | | | |
| Thickness | | Tip | Output | Amperage | Speed (Per Minute) | | Standoff | | Plasma Gas Press | | Flow (CFH) | | Pierce | Pierce Height | |
| Inches | mm | (Cat. No.) | Volts(VDC) | (Amps) | Inches | Meters | Inches | mm | psi* | bar | Plasma | Total** | Delay (Sec) | Inches | mm |
| 0.06 | 1.5 | 9-8210 | 110 | 60 | 165 | 4.19 | 0.13 | 3.2 | 70 | 4.8 | 90 | 245 | 0.00 | 0.20 | 5.1 |
| 0.075 | 1.9 | 9-8210 | 116 | 60 | 155 | 3.94 | 0.13 | 3.2 | 70 | 4.8 | 90 | 245 | 0.10 | 0.20 | 5.1 |
| 0.120 | 3.0 | 9-8210 | 115 | 60 | 125 | 3.18 | 0.13 | 3.2 | 70 | 4.8 | 90 | 245 | 0.10 | 0.20 | 5.1 |
| 0.135 | 3.4 | 9-8210 | 118 | 60 | 80 | 2.03 | 0.13 | 3.2 | 70 | 4.8 | 90 | 245 | 0.10 | 0.20 | 5.1 |
| 0.188 | 4.8 | 9-8210 | 120 | 60 | 75 | 1.91 | 0.13 | 3.2 | 70 | 4.8 | 90 | 245 | 0.20 | 0.20 | 5.1 |
| 0.250 | 6.4 | 9-8210 | 121 | 60 | 60 | 1.52 | 0.13 | 3.2 | 70 | 4.8 | 90 | 245 | 0.30 | 0.20 | 5.1 |
| 0.375 | 9.5 | 9-8210 | 129 | 60 | 28 | 0.71 | 0.13 | 3.2 | 70 | 4.8 | 90 | 245 | 0.50 | 0.20 | 5.1 |
| 0.500 | 12.7 | 9-8210 | 135 | 60 | 17 | 0.43 | 0.19 | 4.8 | 70 | 4.8 | 90 | 245 | 0.75 | 0.20 | 5.1 |
| 0.625 | 15.9 | 9-8210 | 135 | 60 | 14 | 0.36 | 0.19 | 4.8 | 70 | 4.8 | 90 | 245 | NR | NR | NR |
| 0.750 | 19.1 | 9-8210 | 142 | 60 | 10 | 0.25 | 0.19 | 4.8 | 70 | 4.8 | 90 | 245 | NR | NR | NR |

| Type Torch: SL100 With Shielded Tip | | | | | | | Type Material: Aluminum | | | | | | | | |
|-------------------------------------|------|------------|------------|----------|--------------------|--------|--------------------------------------|-----|------------------|-----|------------|---------|-------------|---------------|-----|
| Type Plasma Gas: Air | | | | | | | Type Secondary Gas: Single Gas Torch | | | | | | | | |
| Thickness | | Tip | Output | Amperage | Speed (Per Minute) | | Standoff | | Plasma Gas Press | | Flow (CFH) | | Pierce | Pierce Height | |
| Inches | mm | (Cat. No.) | Volts(VDC) | (Amps) | Inches | Meters | Inches | mm | psi* | bar | Plasma | Total** | Delay (Sec) | Inches | mm |
| 0.060 | 1.5 | 9-8210 | 105 | 60 | 350 | 8.89 | 0.13 | 3.2 | 70 | 4.8 | 90 | 245 | 0.00 | 0.20 | 5.1 |
| 0.075 | 1.9 | 9-8210 | 110 | 60 | 350 | 8.89 | 0.13 | 3.2 | 70 | 4.8 | 90 | 245 | 0.10 | 0.20 | 5.1 |
| 0.120 | 3.0 | 9-8210 | 110 | 60 | 275 | 6.99 | 0.13 | 3.2 | 70 | 4.8 | 90 | 245 | 0.10 | 0.20 | 5.1 |
| 0.188 | 3.4 | 9-8210 | 122 | 60 | 140 | 3.56 | 0.13 | 3.2 | 70 | 4.8 | 90 | 245 | 0.20 | 0.20 | 5.1 |
| 0.250 | 6.4 | 9-8210 | 134 | 60 | 80 | 2.03 | 0.19 | 4.8 | 70 | 4.8 | 90 | 245 | 0.30 | 0.20 | 5.1 |
| 0.375 | 9.5 | 9-8210 | 140 | 60 | 45 | 1.14 | 0.19 | 4.8 | 70 | 4.8 | 90 | 245 | 0.50 | 0.20 | 5.1 |
| 0.500 | 12.7 | 9-8210 | 144 | 60 | 26 | 0.66 | 0.19 | 4.8 | 70 | 4.8 | 90 | 245 | 0.80 | 0.20 | 5.1 |
| 0.625 | 15.9 | 9-8210 | 145 | 60 | 19 | 0.48 | 0.19 | 4.8 | 70 | 4.8 | 90 | 245 | NR | NR | NR |
| 0.750 | 19.1 | 9-8210 | 150 | 60 | 15 | 0.38 | 0.19 | 4.8 | 70 | 4.8 | 90 | 245 | NR | NR | NR |

| Type Torch: SL100 With Shielded Tip | | | | | | | Type Material: Mild Steel | | | | | | | | |
|-------------------------------------|------|------------|------------|----------|--------------------|--------|--------------------------------------|-----|------------------|-----|------------|---------|-------------|---------------|-----|
| Type Plasma Gas: Air | | | | | | | Type Secondary Gas: Single Gas Torch | | | | | | | | |
| Thickness | | Tip | Output | Amperage | Speed (Per Minute) | | Standoff | | Plasma Gas Press | | Flow (CFH) | | Pierce | Pierce Height | |
| Inches | mm | (Cat. No.) | Volts(VDC) | (Amps) | Inches | Meters | Inches | mm | psi* | bar | Plasma | Total** | Delay (Sec) | Inches | mm |
| 0.060 | 1.5 | 9-8211 | 128 | 80 | 280 | 7.11 | 0.19 | 4.8 | 65 | 4.5 | 115 | 340 | 0.00 | 0.2 | 5.1 |
| 0.120 | 3.0 | 9-8211 | 126 | 80 | 203 | 5.16 | 0.19 | 4.8 | 65 | 4.5 | 115 | 340 | 0.10 | 0.2 | 5.1 |
| 0.135 | 3.4 | 9-8211 | 128 | 80 | 182 | 4.62 | 0.19 | 4.8 | 65 | 4.5 | 115 | 340 | 0.10 | 0.2 | 5.1 |
| 0.188 | 4.8 | 9-8211 | 128 | 80 | 137 | 3.48 | 0.19 | 4.8 | 65 | 4.5 | 115 | 340 | 0.20 | 0.2 | 5.1 |
| 0.250 | 6.4 | 9-8211 | 131 | 80 | 100 | 2.54 | 0.19 | 4.8 | 65 | 4.5 | 115 | 340 | 0.30 | 0.2 | 5.1 |
| 0.375 | 9.5 | 9-8211 | 134 | 80 | 40 | 1.02 | 0.19 | 4.8 | 65 | 4.5 | 115 | 340 | 0.50 | 0.2 | 5.1 |
| 0.500 | 12.7 | 9-8211 | 136 | 80 | 36 | 0.91 | 0.19 | 4.8 | 65 | 4.5 | 115 | 340 | 0.60 | 0.2 | 5.1 |
| 0.625 | 15.9 | 9-8211 | 145 | 80 | 21 | 0.53 | 0.19 | 4.8 | 65 | 4.5 | 115 | 340 | 0.75 | 0.2 | 5.1 |
| 0.750 | 19.1 | 9-8211 | 144 | 80 | 14 | 0.36 | 0.19 | 4.8 | 65 | 4.5 | 115 | 340 | NR | NR | NR |
| 0.875 | 22.2 | 9-8211 | 149 | 80 | 11 | 0.28 | 0.19 | 4.8 | 65 | 4.5 | 115 | 340 | NR | NR | NR |
| 1.000 | 25.4 | 9-8211 | 162 | 80 | 8 | 0.20 | 0.19 | 4.8 | 65 | 4.5 | 115 | 340 | NR | NR | NR |

| Type Torch: SL100 With Shielded Tip | | | | | | | Type Material: Stainless Steel | | | | | | | | |
|-------------------------------------|------|------------|------------|----------|--------------------|--------|--------------------------------------|-----|------------------|-----|------------|---------|-------------|---------------|-----|
| Type Plasma Gas: Air | | | | | | | Type Secondary Gas: Single Gas Torch | | | | | | | | |
| Thickness | | Tip | Output | Amperage | Speed (Per Minute) | | Standoff | | Plasma Gas Press | | Flow (CFH) | | Pierce | Pierce Height | |
| Inches | mm | (Cat. No.) | Volts(VDC) | (Amps) | Inches | Meters | Inches | mm | psi* | bar | Plasma | Total** | Delay (Sec) | Inches | mm |
| 0.060 | 1.5 | 9-8211 | 110 | 80 | 340 | 8.50 | 0.125 | 3.2 | 65 | 4.5 | 115 | 340 | 0.00 | 0.2 | 5.1 |
| 0.120 | 3.0 | 9-8211 | 115 | 80 | 260 | 6.50 | 0.125 | 3.2 | 65 | 4.5 | 115 | 340 | 0.10 | 0.2 | 5.1 |
| 0.135 | 3.4 | 9-8211 | 113 | 80 | 250 | 6.25 | 0.125 | 3.2 | 65 | 4.5 | 115 | 340 | 0.10 | 0.2 | 5.1 |
| 0.188 | 4.8 | 9-8211 | 114 | 80 | 170 | 4.25 | 0.125 | 3.2 | 65 | 4.5 | 115 | 340 | 0.20 | 0.2 | 5.1 |
| 0.250 | 6.4 | 9-8211 | 116 | 80 | 85 | 2.13 | 0.125 | 3.2 | 65 | 4.5 | 115 | 340 | 0.30 | 0.2 | 5.1 |
| 0.375 | 9.5 | 9-8211 | 123 | 80 | 45 | 1.13 | 0.125 | 3.2 | 65 | 4.5 | 115 | 340 | 0.40 | 0.25 | 6.4 |
| 0.500 | 12.7 | 9-8211 | 133 | 80 | 18 | 0.45 | 0.125 | 3.2 | 65 | 4.5 | 115 | 340 | 0.75 | 0.25 | 6.4 |
| 0.625 | 15.9 | 9-8211 | 135 | 80 | 16 | 0.40 | 0.125 | 3.2 | 65 | 4.5 | 115 | 340 | 1.00 | 0.25 | 6.4 |
| 0.750 | 19.1 | 9-8211 | 144 | 80 | 8 | 0.20 | 0.125 | 3.2 | 65 | 4.5 | 115 | 340 | NR | NR | NR |
| 0.875 | 22.2 | 9-8211 | 137 | 80 | 8 | 0.20 | 0.125 | 3.2 | 65 | 4.5 | 115 | 340 | NR | NR | NR |
| 1.000 | 25.4 | 9-8211 | 140 | 80 | 8 | 0.20 | 0.125 | 3.2 | 65 | 4.5 | 115 | 340 | NR | NR | NR |

| Type Torch: SL100 With Shielded Tip | | | | | | | Type Material: Aluminum | | | | | | | | |
|-------------------------------------|------|------------|------------|----------|--------------------|--------|--------------------------------------|-----|------------------|-----|------------|---------|-------------|---------------|-----|
| Type Plasma Gas: Air | | | | | | | Type Secondary Gas: Single Gas Torch | | | | | | | | |
| Thickness | | Tip | Output | Amperage | Speed (Per Minute) | | Standoff | | Plasma Gas Press | | Flow (CFH) | | Pierce | Pierce Height | |
| Inches | mm | (Cat. No.) | Volts(VDC) | (Amps) | Inches | Meters | Inches | mm | psi* | bar | Plasma | Total** | Delay (Sec) | Inches | mm |
| 0.06 | 1.5 | 9-8211 | 115 | 80 | 320 | 8.13 | 0.13 | 3.2 | 65 | 4.5 | 115 | 340 | 0.00 | 0.25 | 6.4 |
| 0.12 | 3.0 | 9-8211 | 120 | 80 | 240 | 6.10 | 0.13 | 3.2 | 65 | 4.5 | 115 | 340 | 0.10 | 0.25 | 6.4 |
| 0.188 | 4.8 | 9-8211 | 120 | 80 | 165 | 4.19 | 0.13 | 3.2 | 65 | 4.5 | 115 | 340 | 0.20 | 0.25 | 6.4 |
| 0.250 | 6.4 | 9-8211 | 124 | 80 | 100 | 2.54 | 0.13 | 3.2 | 65 | 4.5 | 115 | 340 | 0.30 | 0.25 | 6.4 |
| 0.375 | 9.5 | 9-8211 | 138 | 80 | 60 | 1.52 | 0.19 | 4.8 | 65 | 4.5 | 115 | 340 | 0.40 | 0.25 | 6.4 |
| 0.500 | 12.7 | 9-8211 | 141 | 80 | 36 | 0.91 | 0.19 | 4.8 | 65 | 4.5 | 115 | 340 | 0.60 | 0.25 | 6.4 |
| 0.625 | 15.9 | 9-8211 | 142 | 80 | 26 | 0.66 | 0.19 | 4.8 | 65 | 4.5 | 115 | 340 | 0.75 | 0.25 | 6.4 |
| 0.750 | 19.1 | 9-8211 | 150 | 80 | 18 | 0.46 | 0.19 | 4.8 | 65 | 4.5 | 115 | 340 | NR | NR | NR |
| 0.875 | 22.2 | 9-8211 | 156 | 80 | 8 | 0.20 | 0.19 | 4.8 | 65 | 4.5 | 115 | 340 | NR | NR | NR |
| 1.000 | 25.4 | 9-8211 | 164 | 80 | 6 | 0.15 | 0.19 | 4.8 | 65 | 4.5 | 115 | 340 | NR | NR | NR |

CUTMASTER 40mm

| Type Torch: SL100 With Shielded Tip | | | | | | | Type Material: Mild Steel | | | | | | | | |
|-------------------------------------|------|------------|------------|----------|--------------------|--------|--------------------------------------|-----|------------------|-----|------------|---------|-------------|---------------|-----|
| Type Plasma Gas: Air | | | | | | | Type Secondary Gas: Single Gas Torch | | | | | | | | |
| Thickness | | Tip | Output | Amperage | Speed (Per Minute) | | Standoff | | Plasma Gas Press | | Flow (CFH) | | Pierce | Pierce Height | |
| Inches | mm | (Cat. No.) | Volts(VDC) | (Amps) | Inches | Meters | Inches | mm | psi* | bar | Plasma | Total** | Delay (Sec) | Inches | mm |
| 0.250 | 6.4 | 9-8212 | 124 | 100 | 110 | 2.80 | 0.180 | 4.6 | 75 | 5.2 | 130 | 390 | 0.4 | 0.200 | 5.1 |
| 0.375 | 9.5 | 9-8212 | 127 | 100 | 75 | 1.90 | 0.180 | 4.6 | 75 | 5.2 | 130 | 390 | 0.5 | 0.200 | 5.1 |
| 0.500 | 12.7 | 9-8212 | 132 | 100 | 50 | 1.30 | 0.180 | 4.6 | 75 | 5.2 | 130 | 390 | 0.6 | 0.200 | 5.1 |
| 0.625 | 15.9 | 9-8212 | 136 | 100 | 30 | 0.75 | 0.180 | 4.6 | 75 | 5.2 | 130 | 390 | 0.8 | 0.200 | 5.1 |
| 0.750 | 19.0 | 9-8212 | 140 | 100 | 18 | 0.45 | 0.190 | 4.8 | 75 | 5.2 | 130 | 390 | 2.0 | 0.225 | 5.7 |
| 1.000 | 25.4 | 9-8212 | 147 | 100 | 10 | 0.25 | 0.190 | 4.8 | 75 | 5.2 | 130 | 390 | NR | NR | NR |

| Type Torch: SL100 With Shielded Tip | | | | | | | Type Material: Stainless Steel | | | | | | | | |
|-------------------------------------|------|------------|------------|----------|--------------------|--------|--------------------------------------|-----|------------------|-----|------------|---------|-------------|---------------|-----|
| Type Plasma Gas: Air | | | | | | | Type Secondary Gas: Single Gas Torch | | | | | | | | |
| Thickness | | Tip | Output | Amperage | Speed (Per Minute) | | Standoff | | Plasma Gas Press | | Flow (CFH) | | Pierce | Pierce Height | |
| Inches | mm | (Cat. No.) | Volts(VDC) | (Amps) | Inches | Meters | Inches | mm | psi* | bar | Plasma | Total** | Delay (Sec) | Inches | mm |
| 0.250 | 6.4 | 9-8212 | 121 | 100 | 110 | 2.80 | 0.125 | 3.2 | 75 | 5.2 | 130 | 390 | 0.5 | 0.200 | 5.1 |
| 0.375 | 9.5 | 9-8212 | 125 | 100 | 60 | 1.50 | 0.150 | 3.8 | 75 | 5.2 | 130 | 390 | 0.8 | 0.200 | 5.1 |
| 0.500 | 12.7 | 9-8212 | 132 | 100 | 35 | 0.90 | 0.150 | 3.8 | 75 | 5.2 | 130 | 390 | 1.0 | 0.200 | 5.1 |
| 0.625 | 15.9 | 9-8212 | 137 | 100 | 20 | 0.50 | 0.150 | 3.8 | 75 | 5.2 | 130 | 390 | 2.0 | 0.225 | 5.7 |
| 0.750 | 19.0 | 9-8212 | 144 | 100 | 15 | 0.40 | 0.190 | 4.8 | 75 | 5.2 | 130 | 390 | NR | NR | NR |
| 1.000 | 25.4 | 9-8212 | 154 | 100 | 8 | 0.20 | 0.190 | 4.8 | 75 | 5.2 | 130 | 390 | NR | NR | NR |

| Type Torch: SL100 With Shielded Tip | | | | | | | Type Material: Aluminum | | | | | | | | |
|-------------------------------------|------|------------|------------|----------|--------------------|--------|--------------------------------------|----|------------------|-----|------------|---------|-------------|---------------|-----|
| Type Plasma Gas: Air | | | | | | | Type Secondary Gas: Single Gas Torch | | | | | | | | |
| Thickness | | Tip | Output | Amperage | Speed (Per Minute) | | Standoff | | Plasma Gas Press | | Flow (CFH) | | Pierce | Pierce Height | |
| Inches | mm | (Cat. No.) | Volts(VDC) | (Amps) | Inches | Meters | Inches | mm | psi* | bar | Plasma | Total** | Delay (Sec) | Inches | mm |
| 0.250 | 6.4 | 9-8212 | 120 | 100 | 120 | 3.05 | 0.180 | | 65 | 4.5 | 105 | 360 | 0.2 | 0.225 | 5.7 |
| 0.375 | 9.5 | 9-8212 | 128 | 100 | 65 | 1.65 | 0.180 | | 65 | 4.5 | 105 | 360 | 0.4 | 0.225 | 5.7 |
| 0.500 | 12.7 | 9-8212 | 130 | 100 | 45 | 1.15 | 0.180 | | 65 | 4.5 | 105 | 360 | 0.5 | 0.225 | 5.7 |
| 0.625 | 15.9 | 9-8212 | 135 | 100 | 30 | 0.75 | 0.180 | | 65 | 4.5 | 105 | 360 | 0.8 | 0.225 | 5.7 |
| 0.750 | 19.0 | 9-8212 | 140 | 100 | 25 | 0.65 | 0.180 | | 65 | 4.5 | 105 | 360 | 1.0 | 0.225 | 5.7 |
| 1.000 | 25.4 | 9-8212 | 148 | 100 | 10 | 0.25 | 0.190 | | 65 | 4.5 | 105 | 360 | NR | NR | NR |

| Type Torch: SL100 With Shielded Tip | | | | | | | Type Material: Mild Steel | | | | | | | | |
|-------------------------------------|------|------------|------------|----------|--------------------|--------|--------------------------------------|-----|------------------|-----|------------|---------|-------------|---------------|-----|
| Type Plasma Gas: Air | | | | | | | Type Secondary Gas: Single Gas Torch | | | | | | | | |
| Thickness | | Tip | Output | Amperage | Speed (Per Minute) | | Standoff | | Plasma Gas Press | | Flow (CFH) | | Pierce | Pierce Height | |
| Inches | mm | (Cat. No.) | Volts(VDC) | (Amps) | Inches | Meters | Inches | mm | psi* | bar | Plasma | Total** | Delay (Sec) | Inches | mm |
| 0.250 | 6.4 | 9-8253 | 140 | 120 | 165 | 4.19 | 0.125 | 3.2 | 75 | 5.2 | 180 | 360 | 0.20 | 0.20 | 5.1 |
| 0.375 | 9.5 | 9-8253 | 142 | 120 | 85 | 2.16 | 0.125 | 3.2 | 75 | 5.2 | 180 | 360 | 0.50 | 0.20 | 5.1 |
| 0.500 | 12.7 | 9-8253 | 144 | 120 | 75 | 1.91 | 0.125 | 3.2 | 75 | 5.2 | 180 | 360 | 0.70 | 0.20 | 5.1 |
| 0.625 | 15.9 | 9-8253 | 150 | 120 | 50 | 1.27 | 0.125 | 3.2 | 75 | 5.2 | 180 | 360 | 0.80 | 0.20 | 5.1 |
| 0.750 | 19.0 | 9-8253 | 154 | 120 | 30 | 0.76 | 0.150 | 3.8 | 75 | 5.2 | 180 | 360 | 1.50 | 0.20 | 5.1 |
| 0.875 | 22.2 | 9-8253 | 158 | 120 | 25 | 0.64 | 0.150 | 3.8 | 75 | 5.2 | 180 | 360 | NR | NR | NR |
| 1.000 | 25.4 | 9-8253 | 160 | 120 | 20 | 0.51 | 0.150 | 3.8 | 75 | 5.2 | 180 | 360 | NR | NR | NR |
| 1.250 | 31.8 | 9-8253 | 170 | 120 | 13 | 0.33 | 0.175 | 4.4 | 75 | 5.2 | 180 | 360 | NR | NR | NR |
| 1.500 | 38.1 | 9-8253 | 176 | 120 | 8 | 0.20 | 0.175 | 4.4 | 75 | 5.2 | 180 | 360 | NR | NR | NR |

| Type Torch: SL100 With Shielded Tip | | | | | | | Type Material: Stainless Steel | | | | | | | | |
|-------------------------------------|------|------------|------------|----------|--------------------|--------|--------------------------------------|-----|------------------|-----|------------|---------|-------------|---------------|-----|
| Type Plasma Gas: Air | | | | | | | Type Secondary Gas: Single Gas Torch | | | | | | | | |
| Thickness | | Tip | Output | Amperage | Speed (Per Minute) | | Standoff | | Plasma Gas Press | | Flow (CFH) | | Pierce | Pierce Height | |
| Inches | mm | (Cat. No.) | Volts(VDC) | (Amps) | Inches | Meters | Inches | mm | psi* | bar | Plasma | Total** | Delay (Sec) | Inches | mm |
| 0.250 | 6.4 | 9-8253 | 136 | 120 | 180 | 4.57 | 0.13 | 3.2 | 75 | 5.2 | 180 | 360 | 0.20 | 0.20 | 5.1 |
| 0.375 | 9.5 | 9-8253 | 144 | 120 | 100 | 2.54 | 0.13 | 3.2 | 75 | 5.2 | 180 | 360 | 0.40 | 0.20 | 5.1 |
| 0.500 | 12.7 | 9-8253 | 149 | 120 | 60 | 1.52 | 0.13 | 3.2 | 75 | 5.2 | 180 | 360 | 0.80 | 0.20 | 5.1 |
| 0.625 | 15.9 | 9-8253 | 153 | 120 | 40 | 1.02 | 0.15 | 3.8 | 75 | 5.2 | 180 | 360 | 1.20 | 0.20 | 5.1 |
| 0.750 | 19.1 | 9-8253 | 157 | 120 | 30 | 0.76 | 0.15 | 3.8 | 75 | 5.2 | 180 | 360 | NR | NR | NR |
| 1.000 | 25.4 | 9-8253 | 162 | 120 | 20 | 0.51 | 0.15 | 3.8 | 75 | 5.2 | 180 | 360 | NR | NR | NR |
| 1.250 | 31.8 | 9-8253 | 165 | 120 | 10 | 0.25 | 0.15 | 3.8 | 75 | 5.2 | 180 | 360 | NR | NR | NR |

| Type Torch: SL100 With Shielded Tip | | | | | | | Type Material: Aluminum | | | | | | | | |
|-------------------------------------|------|------------|------------|----------|--------------------|--------|--------------------------------------|-----|------------------|-----|------------|---------|-------------|---------------|-----|
| Type Plasma Gas: Air | | | | | | | Type Secondary Gas: Single Gas Torch | | | | | | | | |
| Thickness | | Tip | Output | Amperage | Speed (Per Minute) | | Standoff | | Plasma Gas Press | | Flow (CFH) | | Pierce | Pierce Height | |
| Inches | mm | (Cat. No.) | Volts(VDC) | (Amps) | Inches | Meters | Inches | mm | psi* | bar | Plasma | Total** | Delay (Sec) | Inches | mm |
| 0.250 | 6.4 | 9-8253 | 144 | 120 | 190 | 4.83 | 0.13 | 3.2 | 75 | 5.2 | 180 | 360 | 0.20 | 0.20 | 5.1 |
| 0.375 | 9.5 | 9-8253 | 148 | 120 | 120 | 3.05 | 0.13 | 3.2 | 75 | 5.2 | 180 | 360 | 0.50 | 0.20 | 5.1 |
| 0.500 | 12.7 | 9-8253 | 152 | 120 | 75 | 1.91 | 0.15 | 3.8 | 75 | 5.2 | 180 | 360 | 0.70 | 0.20 | 5.1 |
| 0.625 | 15.9 | 9-8253 | 162 | 120 | 45 | 1.14 | 0.15 | 3.8 | 75 | 5.2 | 180 | 360 | 1.00 | 0.20 | 5.1 |
| 0.750 | 19.1 | 9-8253 | 163 | 120 | 35 | 0.89 | 0.15 | 3.8 | 75 | 5.2 | 180 | 360 | NR | NR | NR |
| 1.000 | 25.4 | 9-8253 | 168 | 120 | 20 | 0.51 | 0.15 | 3.8 | 75 | 5.2 | 180 | 360 | NR | NR | NR |

NOTES

* Gas pressure shown is for torches with leads up to 25' / 7.6 m long. For 50' / 15.2 m leads, refer to section 4.02 "Operating Pressure".

** Total flow rate includes plasma and secondary gas flow.

PATENT INFORMATION**Plasma Cutting Torch Patents**

The following parts are covered under U.S. and Foreign Patents as follows:

| Catalog # | Description | Patent(s) |
|------------------|--------------------|---|
| 9-8215 | Electrode | US Pat No(s) 6163008; 6987238 Other Pat(s) Pending |
| 9-8213 | Cartridge | US Pat No(s) 6903301; 6717096; 6936786; 6703581; D496842; D511280; D492709; D499620; D504142 Other Pat(s) Pending |
| 9-8205 | Tip | US Pat No(s) 6774336; 7145099; 6933461 Other Pat(s) Pending |
| 9-8206 | Tip | US Pat No(s) 6774336; 7145099; 6933461 Other Pat(s) Pending |
| 9-8207 | Tip | US Pat No(s) 6774336; 7145099; 6933461 Other Pat(s) Pending |
| 9-8252 | Tip | US Pat No(s) 6774336; 7145099; 6933461 Other Pat(s) Pending |
| 9-8208 | Tip | US Pat No(s) 6774336; 7145099; 6933461 Other Pat(s) Pending |
| 9-8209 | Tip | US Pat No(s) 6774336; 7145099; 6933461 Other Pat(s) Pending |
| 9-8210 | Tip | US Pat No(s) 6774336; 7145099; 6933461 Other Pat(s) Pending |
| 9-8231 | Tip | US Pat No(s) 6774336; 7145099; 6933461 Other Pat(s) Pending |
| 9-8211 | Tip | US Pat No(s) 6774336; 7145099; 6933461 Other Pat(s) Pending |
| 9-8212 | Tip | US Pat No(s) 6774336; 7145099; 6933461 Other Pat(s) Pending |
| 9-8253 | Tip | US Pat No(s) 6774336; 7145099; 6933461 Other Pat(s) Pending |
| 9-8225 | Tip | US Pat No(s) 6774336; 7145099; 6933461 Other Pat(s) Pending |
| 9-8226 | Tip | US Pat No(s) 6774336; 7145099; 6933461 Other Pat(s) Pending |
| 9-8227 | Tip | US Pat No(s) 6774336; 7145099; 6933461 Other Pat(s) Pending |
| 9-8228 | Tip | US Pat No(s) 6774336; 7145099; 6933461 Other Pat(s) Pending |
| 9-8241 | Shield Cap | US Pat No(s) 6914211; D505309 Other Pat(s) Pending |
| 9-8243 | Shield Cap | US Pat No(s) 6914211; D493183 Other Pat(s) Pending |
| 9-8235 | Shield Cap | US Pat No(s) 6914211; D505309 Other Pat(s) Pending |
| 9-8236 | Shield Cap | US Pat No(s) 6914211; D505309 Other Pat(s) Pending |
| 9-8237 | Shield Cup | US Pat No(s) 6914211; D501632; D511633 Other Pat(s) Pending |
| 9-8238 | Shield Cap | US Pat No(s) 6914211; D496951 Other Pat(s) Pending |
| 9-8239 | Shield Cap | US Pat No(s) 6914211; D496951 Other Pat(s) Pending |
| 9-8244 | Shield Cap | US Pat No(s) 6914211; D505309 Other Pat(s) Pending |

| Catalog # | Description | Patent(s) |
|------------------|--------------------|---|
| 9-8245 | Shield Cap | US Pat No(s) 6914211; D496951 Other Pat(s) Pending |

The following parts are also licensed under U.S. Patent No. 5,120,930 and 5,132,512:

| Catalog # | Description |
|------------------|--------------------|
| 9-8235 | Shield Cap |
| 9-8236 | Shield Cap |
| 9-8237 | Shield Cup |
| 9-8238 | Shield Cap |
| 9-8239 | Shield Cap |
| 9-8244 | Shield Cap |
| 9-8245 | Shield Cap |

This Page Intentionally Blank

SECTION 5 SYSTEM: SERVICE

5.01 General Maintenance



Warning!
Disconnect input power before maintaining.

Maintain more often
if used under severe
conditions

Each Use

Visual check of
torch tip and electrode



Weekly

Visually inspect the torch body tip,
electrode, start cartridge and shield cup



Visually inspect the
cables and leads.
Replace as needed

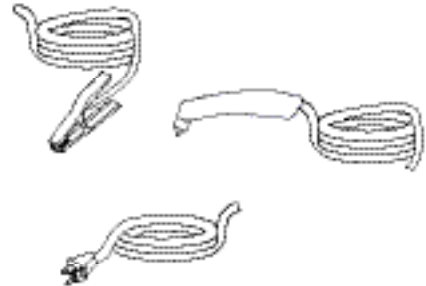

3 Months

Replace all
broken parts



Clean
exterior
of power supply

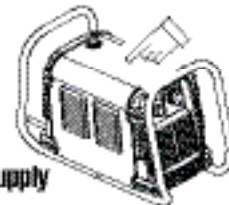

6 Months

Visually check and
Carefully clean the
interior

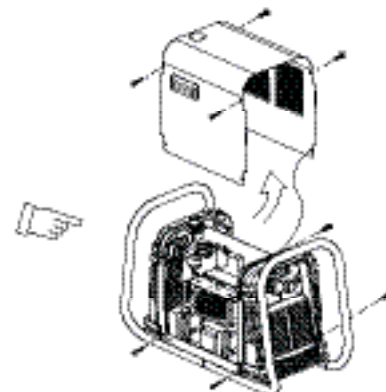

CUTMASTER 40MM

5.02 Maintenance Schedule

NOTE

The actual frequency of maintenance may need to be adjusted according to the operating environment.

Daily Operational Checks or Every Six Cutting Hours:

1. Check torch consumable parts, replace if damaged, worn or when cut performance has diminished.
2. Check plasma and secondary supply and pressure.
3. Purge plasma gas line to remove any moisture build-up.

Weekly or Every 30 Cutting Hours:

1. Check fan for proper operation and adequate air flow.
2. Inspect torch for any cracks or exposed wires, replace if necessary.
3. Inspect input power cable for damage or exposed wires, replace if necessary.

Six Months or Every 720 Cutting Hours:

1. Check the in-line air filter(s), clean or replace as required
2. Check cables and hoses for leaks or cracks, replace if necessary.
3. Check all contactor points for severe arcing or pits, replace if necessary.
4. Vacuum dust and dirt *out* of the entire machine.



CAUTION

Do not blow air into the power supply during cleaning. Blowing air into the unit can cause metal particles to interfere with sensitive electrical components and cause damage to the unit.

5.03 Common Faults

| Problem - Symptom | Common Cause |
|---------------------------|--|
| Insufficient Penetration | <ol style="list-style-type: none"> 1. Cutting speed too fast. 2. Torch tilted too much. 3. Metal too thick. 4. Worn torch parts 5. Cutting current too low. 6. Non - Genuine Thermal Dynamics parts used 7. Incorrect gas pressure |
| Main Arc Extinguishes | <ol style="list-style-type: none"> 1. Cutting speed too slow. 2. Torch standoff too high from workpiece. 3. Cutting current too high. 4. Work cable disconnected. 5. Worn torch parts. 6. Non - Genuine Thermal Dynamics parts used |
| Excessive Dross Formation | <ol style="list-style-type: none"> 1. Cutting speed too slow. 2. Torch standoff too high from workpiece. 3. Worn torch parts. 4. Improper cutting current. 5. Non - Genuine Thermal Dynamics parts used 6. Incorrect gas pressure |
| Short Torch Parts Life | <ol style="list-style-type: none"> 1. Oil or moisture in air source. 2. Exceeding system capability (material too thick). 3. Excessive pilot arc time 4. Gas pressure too low. 5. Improperly assembled torch. 6. Non - Genuine Thermal Dynamics parts used |
| Difficult Starting | <ol style="list-style-type: none"> 1. Worn torch parts. 2. Non - Genuine Thermal Dynamics parts used. 3. Incorrect gas pressure. |

5.04 Fault Indicator

At initial power up, two lights will temporarily illuminate for 2-3 seconds to show the version of software used.

To determine the first digit, count the function indicators left to right, 1 through 5. To determine the second digit count the pressure indicators, reading from bottom to top, 0 through 7. In the example below the Temp indicator and 75 psi indicators are on indicating the version would be 2.3.

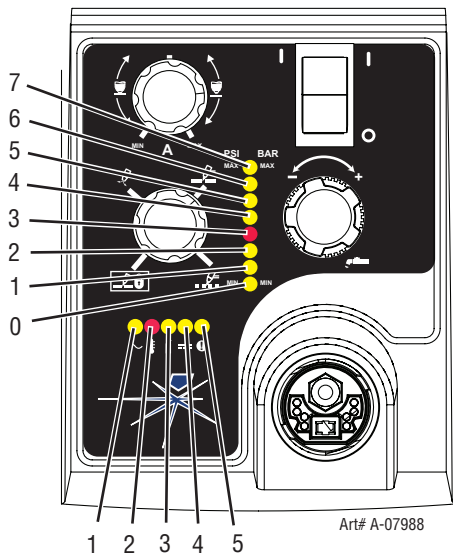

When the  "Fault" indicator is on or blinking it will be accompanied by one of the pressure indicator lights depending on what the Fault is. Only one of these faults will be displayed at one time. If more than one fault exists, when the first fault is corrected and cleared, the next fault will then be displayed. It is possible to have a fault indicated in the function indicators and another fault indicated in the pressure indicators. The following table shows each of the Faults possible.

| Pressure Indicator | Fault |
|--------------------|---------------------|
| Max | Over Pressure |
| 90 | Internal Error |
| 85 | Shorted Torch |
| 80 | Consumables Missing |
| 75 | Start Error |
| 70 | Parts in Place |
| 65 | Input Power |
| Min | Under Pressure |

NOTE

Fault explanations are covered in the basic troubleshooting guide later in this chapter.

Explanation of Faults

UNDER PRESSURE: Indicates that operating pressure is set too low and power supply output power will be disabled.

INPUT POWER: Indicates primary line voltage is outside the operating limits of the power supply.

PART IN PLACE: Indicates that the shield cup is not properly installed or tightened.

START ERROR: Indicates that the START SIGNAL was active (ie. Torch Trigger depressed, hand held pendant switch on or CNC signal for torch on) during one of three (3) conditions:

- 1) During initial power up when ON/OFF switch is turned to ON position
- 2) When fault which had been disabling the system is cleared.
- 3) When the FUNCTION CONTROL SWITCH Mode is moved from SET position to any of the other three (3) modes of operation.

CONSUMABLES MISSING: Indicates that the electrode, start cartridge or tip is missing or excessively worn.

SHORTED TORCH (OUTPUT FAULT): This indicator has two modes of operation:

First is the latched Fault mode. The 85 PSI LED blinks at 1 cycle per second, indicating that one of two fault conditions exist.

- 1) A shorted condition in the torch , leads or consumables.
- 2) Low or no output voltage from the inverter circuits.

In both cases, to reset the machine, turn the unit OFF, identify and clear the problem and turn back ON.

The second mode is a non-latched mode. The 85 PSI LED blinks at 5 cycles per second, indicating one of three fault modes exists:

- 1) While using an Automation Torch at current settings above 45 amps, the tip has contacted the work piece
- 2) Air restriction in torch resulting in low voltage during pilot.
- 3) Low voltage during cutting due to torch or consumable problem.

In all three cases, to reset the machine, remove the START signal.

INTERNAL ERROR: Indicates a microprocessor error.

OVER PRESSURE: Indicates that operating pressure is set too high. The Error Indicator will not flash when the pressure is above 95 PSI. This LED will remain on and the system will operate but pilot starting and cut performance may be affected.

NOTE

When the unit is turned on the cooling fans MOT1-3 will remain off. (In earlier units MOT1 will turn on for .one (1) second and then turns off) The fans will turn on when a START signal (Torch Switch, Remote Pendant switch, or CNC START) is active and will remain on for ten (10) minutes after the START signal is removed. If an over temperature condition occurs, the fans will continue to run while the condition exists and for a ten (10) minute period after the condition is cleared.

This Page Intentionally Blank

CUTMASTER 40MM

5.05 Basic Troubleshooting Guide

WARNING

There are extremely dangerous voltage and power levels present inside this unit. Do not attempt to diagnose or repair unless you have had training in power electronics measurement and troubleshooting techniques.

| Problem - Symptom | Possible Cause | Recommended Action |
|---|--|---|
| ON / OFF Switch is on but the A/C Indicator does not light | <ol style="list-style-type: none"> 1. Primary power disconnect is in OFF position. 2. Primary fuses / breakers are blown or tripped. 3. Faulty components in unit. | <ol style="list-style-type: none"> 1. Turn primary power disconnect switch to ON position. 2. a) Have qualified person check primary fuses / breakers. b) Connect unit to known good primary power receptacle 3. Return to authorized service center for repair or replacement. |
| FAULT indicator flashing, 65 PSI indicator flashing. Fan MOT1 is on. | <ol style="list-style-type: none"> 1. Incorrect Primary line Voltage 2. Primary input voltage problem. 3. Faulty components in unit. | <ol style="list-style-type: none"> 1. Check that appropriate line voltage is connected to unit. 2. Have qualified person check primary voltage to insure it meets unit requirements see section 2.04. 3. Return to authorized service center for repair or replacement. |
| TEMPERATURE indicator on. FAULT indicator flashing | <ol style="list-style-type: none"> 1. Air flow through or around the unit is obstructed. 2. Duty cycle of the unit has been exceeded 3. Failed components in unit | <ol style="list-style-type: none"> 1. Refer to clearance information – section 2.04 2. Allow unit to cool. 3. Return to authorized service center for repair or replacement. |
| GAS indicator off, FAULT and MIN pressure indicators flashing. | <ol style="list-style-type: none"> 1. Gas supply not connected to unit. 2. Gas supply not turned on. 3. Gas supply pressure too low. 4. AIR PRESSURE CONTROL regulator set too low. 5. Failed components in unit. | <ol style="list-style-type: none"> 1. Connect gas supply to unit. 2. Turn gas supply on. 3. Set air supply inlet pressure to unit to 120 psi. 4. Adjust regulator to set air pressure - see section 4.02. 5. Return to authorized service center for repair or replacement. |
| FAULT and 70 PSI indicators flashing. After 20 seconds fan MOT1 turns on. | <ol style="list-style-type: none"> 1. Shield Cup loose. 2. Torch not properly connected to power supply. 3. Problem in torch and leads PIP circuit. 4. Failed components in unit. | <ol style="list-style-type: none"> 1. Hand tighten the shield cup until it is snug. 2. Insure torch ATC is securely fastened to unit. 3. Replace torch and leads or return to authorized service center for repair or replacement. 4. Return to authorized service center for repair or replacement. |
| FAULT and 75 PSI indicators flashing. | <ol style="list-style-type: none"> 1. Start signal is active when ON/OFF SWITCH is turned to ON position. 2. Problem in the torch and leads switch circuit. 3. Failed components in unit. | <ol style="list-style-type: none"> 1. Start can be active for one of the following: <ul style="list-style-type: none"> • Hand torch switch held closed • Hand pendant switch held closed • CNC START signal is active low Release the START signal source 2. Replace torch and leads or return to authorized service center for repair or replacement. 3. Return to authorized service center for repair or replacement. |

| Problem - Symptom | Possible Cause | Recommended Action |
|--|---|---|
| FAULT & 80 PSI indicators flashing. Gas flow is cycling on and off. | <ol style="list-style-type: none"> 1. Torch shield cup is loose. 2. Torch tip, electrode or start cartridge missing. 3. Torch start cartridge is stuck. 4. Open conductor in torch leads. 5. Problem in the torch and leads switch circuit. 6. Failed components in unit. | <ol style="list-style-type: none"> 1. Tighten shield cup by hand. Do not overtighten. 2. Turn off power supply. Remove shield cup. Install missing parts. 3. Turn off power supply. Bleed down system pressure. Remove shield cup, tip and start cartridge. Check start cartridge lower end fitting for free movement. Replace if fitting does not move freely. 4. Replace torch and leads or return to authorized service center for repair or replacement. 5. Replace torch and leads or return to authorized service center for repair or replacement. 6. Return to authorized service center for repair or replacement. |
| Nothing happens when torch switch or remote switch is closed (Or CNC START signal is active) No gas flow, DC LED OFF. | <ol style="list-style-type: none"> 1. Problem in the torch and leads switch circuit (Remote pendant switch circuit). 2. CNC Controller device not providing Start signal. 3. Failed components in unit. | <ol style="list-style-type: none"> 1. Take Torch and Leads (Remote Pendant) to Authorized Repair Facility. 2. Contact Controller manufacturer. 3. Return to authorized service center for repair or replacement. |
| FAULT indicator flashing and 85 PSI indicators flashing. at 1 cycle per second. | <ol style="list-style-type: none"> 1. Upper O-Ring on torch head is in wrong position. 2. Torch start cartridge is stuck. 3. Worn or faulty torch parts. 4. Shorted Torch. | <ol style="list-style-type: none"> 1. Remove shield cup from torch; check upper O-Ring position; correct if necessary. 2. Turn off power supply. Bleed down system pressure. Remove shield cup, tip and start cartridge. Check start cartridge lower end fitting for free movement. Replace if fitting does not move freely. 3. Inspect torch consumable parts. Replace if necessary. 4. Replace torch and leads or return to an authorized service center for repair. |
| FAULT indicator flashing and 85 PSI indicators flashing. at 5 cycles per second | <ol style="list-style-type: none"> 1. Low output voltage during pilot. 2. Low output voltage during cut. 3. For Automation Torch only: Tip contacted work piece during cut with output current set above 45 amps. | <ol style="list-style-type: none"> 1) Check torch consumable parts for wear or foreign debris.* 2) Check torch consumable parts for wear or foreign debris.* 3) Cut with Tip off the plate.* <p>*For these modes, to reset the machine, remove the START signal.</p> |
| No Fault lights on, no arc in torch. | <ol style="list-style-type: none"> 1. Failed components in unit. | <ol style="list-style-type: none"> 1. Return to an authorized service center for repair. |
| FAULT and 90 PSI indicators flashing | <ol style="list-style-type: none"> 1. Internal Error | <ol style="list-style-type: none"> 1. Turn the ON / OFF switch OFF then back ON again. If that does not clear the fault, return to an authorized service center for repair. |
| Pilot arc is on but cutting arc will not establish | <ol style="list-style-type: none"> 1. Work cable not connected to work piece. 2. Work cable/connector broken. 3. Failed components in unit. | <ol style="list-style-type: none"> 1. Connect work cable. 2. Replace work cable. 3. Return to an authorized service center for repair. |
| Torch cutting is diminished | <ol style="list-style-type: none"> 1. Incorrect current setting. 2. Worn torch consumables. 3. Poor work cable connection to work piece. 4. Torch being moved too fast. 5. Excessive oil or water in torch. 6. Failed components in unit. | <ol style="list-style-type: none"> 1. Check and adjust to proper setting. 2. Check torch consumables and replace as needed. 3. Check the connection of the Work Lead to the work piece. 4. Reduce cutting speed. 5. Refer to "Check air quality" in section 3 Torch. 6. Return to an authorized service center for repair. |

5.06 Circuit Fault Isolation



WARNING

The following procedures should not be attempted by anyone who has not had proper training or authorized to do so.

A. Cover Removal

1. Remove the upper and lower screws which secure the cover to the main assembly. Do not loosen the lower screws inside the cut out slots in the bottom of the cover.

Note

The upper screws and lower screws are not the same. Do not mix them. The upper screws are for threading into the plastic of the front and rear panels. DO NOT use the finer threaded lower screws for this.

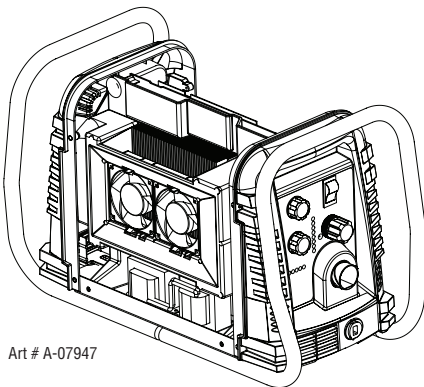
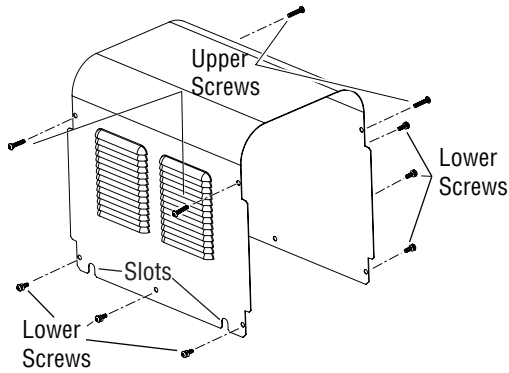

2. Carefully pull the Cover up and away from the unit.

B. Cover Installation

1. Reverse previous procedures for cover installation.

NOTE

When installing the upper screws, attempt to reuse the original threads. The easiest way to do this is by turning the screw counter-clockwise until you feel the threads line up, then begin to turn the screw clockwise to tighten to 15-18 in. lbs.. Do not over tighten.

C. Pre Power Up Tests

Prior to applying primary line power to the unit, perform the following checks to prevent component failure or blowing primary fuses. The troubleshooting guide will assume these tests were done and no failure was found or that any failures found were corrected.

1. Main Contactor (W1) Check - Section 5.11 A
2. PCB 1 Input Diode D1 Test - Section 5.11 B
3. PCB 5 Input Diode D1 Test- Section 5.11 C
4. PCB 2 Capacitor / Relay Test - Section 5.11 D
5. PCB 1 IGBT Test - Section 5.11E
6. PCB 5 IGBT Test - Section 5.11 F
7. PCB 1 Output Diode Test - Section 5.11G
8. PCB 5 Output Diode Test - Section 5.11H
9. PCB 1 Pilot IGBT Test - Section 5.11I

If no fault is found in Pre Power-Up Tests 2-6, skip steps 10-14.

If a fault is found in Pre Power-Up Tests 2-6 remove PCB 2 and perform the following Pre Power-Up Tests to determine which PCBs have failed.

10. PCB 2 Capacitor / Relay Test - Section 5.11J
11. PCB 1 Input Diode (D1) Test - Section 5.11K
12. PCB 5 Input Diode (D1) Test - Section 5.11L
13. PCB 1 IGBT Test - Section 5.11M
14. PCB 5 IGBT Test - Section 5.11N

If all of the Pre Power-Up Tests are ok, proceed with the trouble shooting guide.



CAUTION

Due to the close proximity of the Main Pcb to the Capacitor Pcb, It is recommended to use an insulated meter probe when making measurements on the J2 connector on the Main Pcb. Do not short between the pins. Do not short to the Capacitor Pcb connections.

D. Initial Set up Conditions

This section is to help isolate the defective circuit before troubleshooting, identify symptoms, and test the unit for proper operation. Follow the instructions as given to identify the possible symptom(s) and the defective circuit. After repairs are complete, run the following tests again to verify that the unit is fully operational.

1. Connect gas supply to rear of Power Supply.
2. Turn on gas supply and set operating pressure per pressure setting label on power supply.
3. Set the Power Supply controls as follows:
 - ON/OFF SWITCH to OFF position
 - Turn FUNCTION CONTROL SWITCH to SET position
 - CURRENT CONTROL POTENTIOMETER to MAXIMUM position, fully clockwise.

E. Main Input and Internal Power Test

1. Connect Primary Line power to the unit.
2. Turn the ON/OFF SWITCH (SW1) to ON position and observe the following:
 - Software version is displayed (See section 5.04 Fault Indicators)

After approx. three (3) seconds

- Inrush relay on PCB1 energizes, starting pre-charging of working capacitors.
- AC and GAS Indicators come on
- Gas flows
- After 4 seconds W1 energizes

For earlier units, Fan MOT1 turns on for one (1) second then shuts off.

3. Adjust the pressure regulator to set the gas pressure as specified in charts.

| STANDOFF | | |
|-------------------------------------|----------------------|--------------------------|
| CutMaster 102 Gas Pressure Settings | | |
| Leads Length | SL100 (Hand Torch) | SL100 (Mechanized Torch) |
| Up to 25' (7.6 m) | 75 psi 5.2 bar | 75 psi 5.2 bar |
| Each additional 25' (7.6 m) | Add 5 psi 0.4 bar | Add 5 psi 0.4 bar |

| DRAG | |
|-------------------------------------|--------------------------|
| CutMaster 102 Gas Pressure Settings | |
| Leads Length | SL100 (Mechanized Torch) |
| Up to 25' (7.6 m) | 80 psi 5.5 bar |
| Each additional 25' (7.6 m) | Add 5 psi 0.4 bar |

4. Turn FUNCTION CONTROL SWITCH to RUN position
 - Solenoid turns off, gas stops flowing (pressure display may increase slightly when gas is not flowing)

This completes the Main Input and Internal Power Test. If the above are all correct then proceed to the next section "F. Pilot Arc Test". If the unit does not function as stated above, then note the symptom and proceed to Section "5.07, Main Input and Internal Power Problems".

CUTMASTER 40MM

F. Pilot Arc Test

There are three types of START signals which can be used to begin system operation:

1. Hand Torch - Operator switch mounted on the torch handle.
2. Machine torch or Automation torch:
 - A. Hand heled pendant switch
 - B. CNC cable interfaced to cotroller.
1. Provide a START signal to establish a pilot arc and note the following
 - Cooling fans MOT1-3 turn on.
 - Gas solenoid opens
 - Gas flows
 - After two seconds the gas solenoid closes and gas stops flowing momentarily, then gas solenoid re-opens and gas resumes flowing
 - DC LED comes on
 - Pilot arc is established
2. Remove the START signal and not the following
 - Gas continues to flow
 - DC LED goes off

After 20 second post flow time

- Gas solenoid closes
- Gas flow stops

This completes the Pilot Arc Test. If the above are all correct then proceed to the next section "G, Main Arc and Controls Test". If the unit does not function as stated above, then note the symptom and proceed to Section "5.08, Pilot Arc Problems".

G. Main Arc and Controls Test

Connect work Cable to the work piece, provide a START signal to establish a pilot arc. Bring torch to within 1/8" – 3/8" of the work piece to establish main cutting arc.

- Main Cutting Arc Establishes
 - On PCB 1 D59 turns off and D78 turns on
1. Clamp DC ammeter around the work cable. Output will be 120 amps.

2. While cutting, adjust the CURRENT CONTROL POTENTIOMETER from maximum setting to minimum setting.
 - Current adjusts from 120 amps down to 30 amps
3. Set the CURRENT CONTROL POTENTIOMETER to maximum position.
 - Current adjusts from 30 amps up to 120 amps
4. While cutting, touch the tip of the torch to the work piece, This is called Drag Mode.

For Hand and Machine Torches:

- Tip Saver circuit will activate, current drops to 60 amps.

For Automation Torches:

- The Arc will shut off, the FAULT indicator and the 85 PSI LED will flash at 5 cycles per second. To reset, lift tip off the work piece, remove and re-apply the START signal and go to step 6.
5. Lift tip off the plate approx 1/4"
 - Tip Saver circuit deactivates, current goes back to 120 amps
 6. While cutting keep the torch switch closed, bring the torch off the edge of the material.
 - Cutting arc extinguishes
 - Gas solenoid closes
 - Gas flow stops momentarily then restarts when solenoid opens
 - Pilot arc ignites
 7. Open the torch switch
 - DC LED turns off

After 20 second post flow time

- Gas solenoid closes
 - Gas flow stops
8. Set the FUNCTION CONTROL SWITCH to RAPID AUTO RESTART mode.
 9. Provide a START signal to establish a pilot arc. Bring torch to within 1/8" – 3/8" of the work piece to establish main cutting arc.
 10. While cutting keep the torch switch closed and bring the torch off the edge of the material.
 - Pilot Arc re-ignites immediately

11. Open the torch switch

- DC LED turns off

After 20 second post flow time

- Gas solenoid closes
- Gas flow stops

For Automation Torches - Skip steps 12 & 13

12. Set the FUNCTION CONTROL SWITCH to LATCH mode

13. Start a cut, and remove the START signal.

- Main cutting arc will remain on until the torch is lifted away from the plate approx 3/4" or until the torch is brought off the edge of the metal

Once the arc has extinguished

- DC LED turns off

After 20 second post flow time

- Gas solenoid closes
- Gas flow stops
- Ten (10) minutes after the Start signal is removed, the cooling fans turn off.

This completes the Main Arc and Controls Test. If the above are all correct then proceed to the next section "H CNC Interface Test." If the unit does not function as stated above, then note the symptom and proceed to Section "5.09, Main Arc and Controls Problems".

H. CNC INTERFACE TEST

If the unit has one of the two factory supplied options for CNC interface installed, proceed with this section, otherwise the tests are complete.

1. Connect an ohmmeter between CNC connector (Pins 12& 14 (OK-TO-MOVE signal). Position the torch to pilot. Check the OK-TO-MOVE signal by connecting a jumper between CNC connector pins 3 & 4 (START)
 - Pilot arc is established
2. Bring the torch to the work piece and transfer to cutting arc.
 - OK-TO-MOVE signal is present. (Meter shows continuity)

3. Remove jumper from the CNC connector.

- OK-TO-MOVE signal off (Meter shows no continuity)
- Gas continues to flow
- DC LED goes off

After 20 second Post flow time

- Gas solenoid closes
- Gas flow stops

If the unit has the Basic CNC Interface harness the test is complete. If the unit does not function as stated above, then note the symptom and proceed to Section "5.10 CNC Interface Problems".If the unit has the Automation Interface PCB installed, continue with this section.

4. There are three (3) ARC VOLTS signals available from the J1 connector.

- a) J1-9 (+) to J2-7 (-)
- b) 2-5 (+) to J2-6 (-) (Auto Interface PCB 4 connector P1 with no jumper installed = ARC VOLTS divided by 16.67.
- c) J2-5 (+) to J2-6 (-) (Auto Interface PCB 4 connector P1 with jumper installed between pins 1 and 2) = ARC VOLTS divided by 30
- d) J2-5 (+) to J2-6 (-) (Auto Interface PCB 4 connector P1 with jumper installed between pins 2 and 3) = ARC VOLTS divided by 50

Measure the voltage between these points while piloting (Open Circuit Voltage) and while cutting. The voltages should approx as listed below

| Open Circuit Voltage | Cutting Voltage |
|----------------------|-----------------|
| a) 300 VDC | 100 VDC |
| b) 18 VDC | 6 VDC |
| c) 10 VDC | 3.3 VDC |
| d) 6 VDC | 2 VDC |

This completes the CNC Interface Test. If the above are all correct then the unit is functioning correctly. If the unit does not function as stated, then note the symptom and proceed to Section "5.10, CNC Interface Problems".

5.07 Main Input and Internal Power Problems

A. Primary input line fuse blows as soon as primary disconnect is closed.

1. Primary input cable installed incorrectly.
 - a) For Non EMC units - Check wiring of primary power cable to the W1 contactor

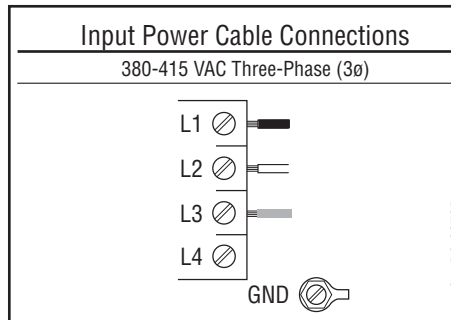

- b) For EMC units - Check wiring of primary power cable to the EMC Filter terminal block.

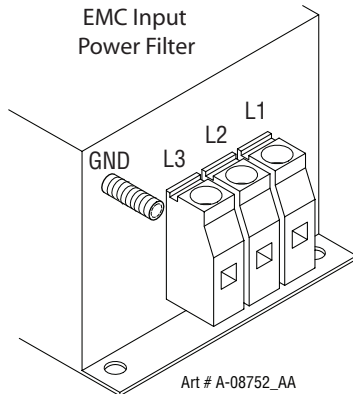

Three Phase Input Power Wiring

2. W1 contactor points are stuck closed
 - a) Check per section 5.11A
 3. Primary plug not wired correctly.
 - a) Check manufacturer's plug installation instructions.
 4. Primary input cable is defective.
 - a) Check cable for shorts.
- ### B. Primary line fuses blow immediately after ON/OFF SWITCH (SW1) is turned to ON position.
1. Shorted Input Diode Module
 - a) Check per section 5.11B and 5.11C
 2. Shorted Input Capacitor PCB 2
 - a) Check per section 5.11D

C. Gas flows with ON/OFF SWITCH in OFF position

1. Foreign debris has lodged in gas solenoid.
 - a) Replace gas solenoid. This is a problem caused by improperly filtered air supply. Customer needs to add filtration to air supply prior to unit inlet.

D. All front panel indicators are off, Fan MOT1 never turns on. Main Contactor W1 does not close.

1. Primary power not connected.
 - a) Check that cable is connected to primary power.
2. Primary line fuse/breaker is blown/tripped.
 - a) Replace fuse or reset breaker.
3. Defective ON/OFF SWITCH
 - a) Check continuity
4. Defective Main PCB 1
 - a) Measure Main Pcb power supply voltages at the following test points
 GND1 to +12V = 12VDC
 GND1 to +48V = 48 VDC

Replace Main PCB 1 if not correct

5. Defective Ribbon Cable
 - a) Check continuity
6. Defective Logic PCB 3
 - a) Replace Logic PCB 3

E. AC LED on, W1 contactor does not energize. (In earlier revision units, the fan MOT1 will come on after approx 20 seconds)

1. Defective contactor.
 - a) Measure for 24vac between wires 5 & 6. If voltage is present, replace W1.
2. Defective Logic PCB 3.
 - a) Measure /W1_ON signal on Logic PCB 3 between J1-9 to TP1. Voltage should be 12VDC then drop to less than 1vdc, 2 seconds after turning SW1 to ON.

3. Open or improperly connected ribbon cable to J2 connector on Main PCB 1
 - a) Inspect connection and check continuity. Replace if open.
- 4) Defective Main PCB 1.
 - a) Replace Main PCB 1.

F. UNDER PRESSURE FAULT. AC LED on, FAULT Indicator and 60 PSI LED flashing.

1. Air pressure source to unit is too low.
 - a) Set input pressure source to 90-100PSI.
2. Regulator set too low.
 - a) Adjust unit regulator to increase pressure.
3. Defective Logic PCB 3
 - a) Measure for 5VDC on the Logic PCB 3 between J3-3 to J3-1. Replace Logic PCB 3 if voltage is not present or low.
 - b) Measure for voltage on the Logic PCB 3 between J3-2 to J3-1. If the voltage is between 3-4.5VDC, replace the Logic PCB 3.
4. Defective Pressure Transducer
 - a) Replace Pressure Transducer

G. INPUT POWER FAULT. AC LED on, FAULT Indicator and 65 PSI LED flashing.

1. Primary line voltage out of tolerance range.
 - a) Connect unit to voltage with unit specifications. See section "2.04 Power supply specifications". If using a generator, connect unit to a wall receptacle to see if problem is corrected.
- 2 Defective Main PCB 1
 - a) Measure voltage on Main PCB 1 between test point GND1 to J2-22.
400 VAC input = approx 2.6 VDC

If voltage is less than 2vdc, replace Main PCB 1.

3. Defective Ribbon cable.
 - a) Check continuity of the ribbon cable connecting between the Main PCB 1 and the Logic PCB 3.
4. Defective Logic PCB 3.
 - a) Replace Logic PCB 3.

H. PARTS-IN-PLACE (PIP) FAULT. The FAULT Indicator and 70 PSI LED flashing, After 20 seconds fan MOT1 turns on.

1. Shield Cup loose
 - a) Hand tighten the shield cup to close the PIP switch.
2. Torch not properly connected to power supply
 - a) Insure torch ATC is securely fastened to unit.
3. Problem with torch and leads PIP circuit
 - a) Disconnect the Torch from the unit and check continuity of torch PIP circuit at ATC pins 1 & 2. If open, check torch and leads for open lead or PIP switch.

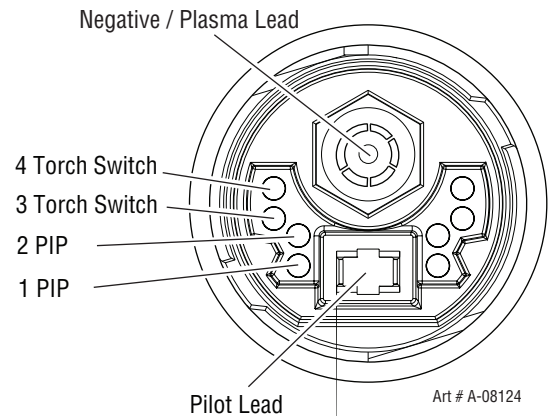

4. Defective Logic PCB 3
 - a) Measure the voltage on Main PCB 1 between J2-17 to test point GND1 for 12VDC. If the voltage is less than 2VDC, Replace Logic Pcb
5. Defective Main PCB 1
 - a) Replace Main PCB 1

CUTMASTER 40MM

I. START ERROR FAULT. The FAULT Indicator and 75 PSI LED flashing.

1. Start signal is active when SW1 is turned to ON position.
 - a) START can be active for one of the following:
 - Hand torch switch held closed
 - Hand pendant switch held closed
 - CNC START signal is active low

Release the START signal source.

2. Problem in the torch and leads switch circuit
 - a) Check continuity of torch switch circuit at ATC pins 3 & 4. See previous illustration.
3. Short in CNC cable
 - a) Check continuity
4. Defective Logic PCB 3
 - a) Measure voltage at Main PCB 1 between J2-16 to test point GND1 for 12VDC. If voltage is present, replace Logic PCB 3.
5. Defective Main PCB 1.
 - a) Replace Main PCB 1.

J. TIP MISSING FAULT. The FAULT Indicator and 80 PSI LED is flashing. Gas solenoid cycles on and off.

1. Torch Shield Cup is loose.
 - a) Tighten shield cup by hand. Do not over tighten.
2. Torch tip, electrode, or start cartridge missing.
 - a) Turn off power supply. Replace missing part(s).
3. Start Cartridge is stuck.
 - a) Turn off power supply. Bleed down the system. Remove the shield cup, tip, start cartridge and electrode. Check the lower end unit of the start cartridge for free movement. Replace the cartridge if the lower end unit does not move freely.

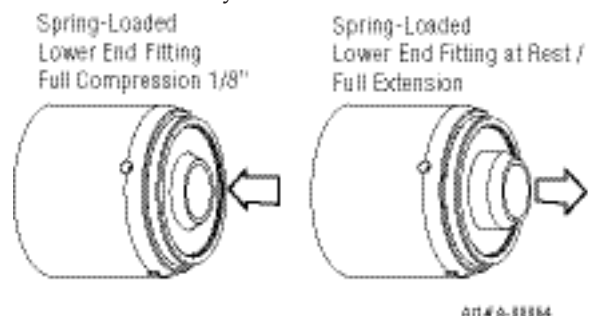

4. Open conductor in torch leads
 - a) Check continuity
5. Defective Main PCB 1.
 - b) Measure voltage between J2-2 connector on Main PCB 1 to test point GND1 for 12VDC. If voltage is present, replace Main PCB 1.
6. Defective Logic PCB 3.
 - a) Replace Logic PCB 3.

K. AC LED on, yellow TEMP LED is on, red FAULT Indicator is flashing all three fans turn on.

1. Air flow through unit is restricted.
 - a) Provide adequate airflow. See Ventillation Clearance Requirements section 2.04.
2. Exceeded duty cycle of the power supply.
 - a) Allow unit to remain on, but at idle, with fan running to cool power supply. See Power Supply Specifications section 2.04 for duty cycle information.

NOTE

When the unit is turned on the cooling fans MOT1-3 will remain off. (In earlier units MOT1 will turn on for .one (1) second and then turns off) The fans will turn on when a START signal (Torch Switch, Remote Pendant switch, or CNC START) is active and will remain on for ten (10) minutes after the START signal is removed. If an over temperature condition occurs, the fans will continue to run while the condition exists and for a ten (10) minute period after the condition is cleared.

3. Defective 40A PCB 5.

Measure for 12VDC on the 40A PCB 5 between J4-4 to J4-10. Replace 40A PCB 5 if voltage is not present.
4. Defective Main PCB 1.
 - a) Measure for 12VDC on Main PCB 1 between J2-21 to TP GND1. Replace Main PCB 1 if voltage is not present.
5. Defective Logic PCB 3.
 - a) Change Logic PCB 3.

L. AC LED on, TEMP, GAS, DC LED's are off, FAULT Indicator is flashing. MIN PRESSURE LED is flashing.

1. Gas supply not connected to unit.
 - a) Connect gas supply to unit.
2. Gas supply not turned on.
 - a) Turn gas supply on.
3. Gas supply pressure too low.
 - a) Set gas supply pressure to 95-120psi.
4. Air Pressure Control Regulator set too low.
 - a) Adjust AIR PRESSURE CONTROL to set pressure as specified in section 4.02 Setting Operational Pressure.
5. Faulty Pressure Transducer.
 - a) a) Adjust pressure Regulator to maximum. Measure voltage on Logic PCB 3 between J3-1 to J3-2. If voltage is more than 2VDC Replace Pressure Transducer.
6. Faulty Logic PCB 3.
 - a) Replace Logic PCB 3.

M. INTERNAL ERROR. FAULT Indicator and 90 PSI LED flashing.

1. There has been a microprocessor problem.
 - a) Turn ON/OFF SWITCH to OFF position and then turn to ON position to clear the error.
1. Faulty Logic PCB 3.
 - a) Replace Logic PCB 3.

N. MAX PRESSURE ERROR. MAX pressure LED is on.

1. Gas pressure set too high.
 - a) Reduce gas pressure.
2. Pressure Regulator set too high.
 - a) Adjust Pressure Regulator.
2. Defective Pressure Transducer.
 - a) Adjust pressure Regulator to minimum. Measure voltage on Logic PCB 3 between J3-1 to J3-2. If voltage is more than 4 VDC Replace Pressure Transducer.
3. Defective Logic PCB 3.
 - a) Replace Logic PCB.

O. AC LED on, TEMP LED off, GAS LED on, Gas flows. DC LED & FAULT indicator off. W1 contactor does not energize.

1. Defective W1 Contactor.
 - a) Measure for 24VAC between wire #5 to wire #6 on W1. If voltage is present replace W1.
- 2) Defective Logic PCB 3.
 - a) Measure voltage on Main PCB 3 between J2-9 to GND1. If voltage is 12VDC, Replace the Logic PCB 3.
- 3) Defective Main PCB 1.
 - a) Replace Main PCB 1.

P. AC LED on, TEMP LED off, GAS LED on, Gas does not flow in SET mode using a hand torch or a machine torch without remote solenoid.

1. Defective gas solenoid (SOL1)
 - a) Measure voltage on Main PCB 1 between J5-1 to J5-3 for 12 VDC. If voltage is present, change SOL 1
2. Defective Logic PCB 3
 - a) Measure on Main PCB 1 signal /SOL_ON between J2-12 to test point GND1 for 12VDC. If voltage is present, replace Logic PCB 3.
3. Defective Main PCB 1.
 - a) Replace Main PCB.

Q. AC LED on, TEMP LED off, GAS LED on, Gas does not flow in SET mode using a machine torch with remote solenoid.

Disconnect the gas solenoid SOL1 from the back of the ATC connector.

If Gas DOES NOT flow out of SOL1 when the unit is in SET mode :

1. Defective gas solenoid (SOL1)
 - a) Measure voltage on Main PCB 1 between J5-1 to J5-3 for 12 VDC. If voltage is present, change SOL 1
2. Defective Logic PCB 3.
 - a) Measure on Main PCB between J2-12 to test point GND1 for 12VDC. If voltage is present, replace Logic PCB 3.
3. Defective Main PCB 1
 - a) Replace Main PCB 1

If gas DOES flow out of SOL1 when the unit is in SET mode, reconnect SOL1 to the ATC connector.

4. Defective torch solenoid.
 - a) Measure the coil terminals of the torch mounted gas solenoid SOL2 for 24vac. If present, replace SOL2.
5. Defective Main PCB 1.
 - a) Measure on Main PCB 1 between J2-20 to GND1 for less than 2VDC.

If voltage is 12VDC replace Main PCB 1

 - b) Measure on Main PCB between J2-11 to GND1 for less than 2VDC. If voltage is less than 2VDC replace Main PCB 1.
6. Defective Logic PCB 3.
 - a) Measure on Main PCB 1 between J2-11 to GND1 for less than 2VDC. If voltage is 12vdc, replace Logic PCB 3.

R. Cannot adjust gas pressure.

1. Inlet gas pressure is too low
 - a) Increase inlet gas pressure to 95-120 psi
2. Faulty regulator.
 - a) Replace Regulator.

If Air flow changes but display does not:
3. Faulty Logic PCB 3.
 - a) Measure on Logic PCB 3 for 12 VDC between TP3 to TP1. If voltage is low or not present, replace Logic PCB 3.
4. Faulty Pressure transducer.
 - a) Measure on Logic PCB 3 between J3-2 to TP1 while adjusting the Pressure regulator from Min to Max. Voltage should adjust from 0-4.5VDC. If voltage does not change, Replace the Pressure Transducer.
5. Faulty Logic PCB 3.
 - a) Measure on Logic PCB 3 between J3-2 to TP1 while adjusting the Pressure regulator from Min to Max. Voltage should adjust from 0-4.5VDC. If voltage does change, Replace the Logic PCB 3.

S. AC LED on, TEMP LED is off, GAS LED is on. Fan MOT1 turns on, plasma gas not flowing. (Earlier revision units).

- 1) Open connection between J2 connector on Capacitor PCB 2 to J3 connector on 40A PCB 5.
 - a) Check continuity.

- 2) Defective Main PCB 1.
 - a) Measure for approx. 325VDC on the CAPACITOR PCB 2 between MTH1 to MTH7. Replace if no voltage present.
- 3) Defective Capacitor PCB 2.
 - a) Disconnect plug from J 2 connector on Capacitor PCB 2 and measure for 12VDC between J2-1 to J2-2. If low or missing, replace PCB 2.
- 4) Defective 40A PCB 5.
 - a) Disconnect plug from J4 on 40A PCB 5. If fan MOT1 turns off, replace PCB 5.
- 5) Defective Main PCB 1.
 - a) Replace PCB 1.

5.08 Pilot Arc Problems

A. AC LED on, TEMP LED off, GAS LED on. Nothing happens when START signal is active. No gas flow, DC LED OFF, fans MOT1-3 do not turn on.

1. Problem in the torch and leads switch circuit (or remote pendant or CNC signal missing)
 - a) For hand torches, Check continuity of torch switch circuit at ATC pins 3 & 4.

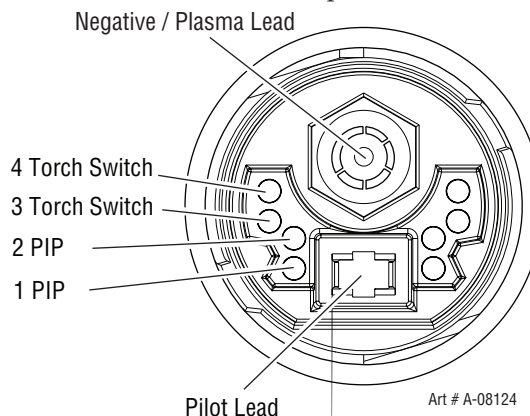

- a) For machine torches using a remote pendant, Check continuity of Pendant switch circuit
- c) Check CNC START signal
2. Defective Logic PCB 3
 - a) Jumper on Main PCB 1 between J2-16 and test point GND1. If gas does not flow, replace Logic PCB 3.
 - b) With START signal active, measure voltage on Main PCB 1 between test points GND1 to I_DMD1 for 1.4VDC. Replace PCB 3 if voltage is not present.

3. Defective Main PCB 1
 - a) With START Signal active, measure voltage on Main PCB 1 between test points GND1 to I_DMD1 for 1.4 VDC. Replace PCB 1 if voltage is present.

B. SHORTED TORCH (OUTPUT) FAULT.
Fault indicator and 85 PSI Indicators are flashing at 1 cycle per second.

This is a Latched Failure Mode. After START signal is activated, gas flows. After two seconds FAULT INDICATOR flashes, and 85 PSI LED flashes. To reset the machine, turn the unit OFF, identify and clear the problem and turn back ON.

1. Upper O-Ring on torch head is in the wrong position.
 - a) Remove shield cup from torch; check position of the upper o-ring and correct if needed.

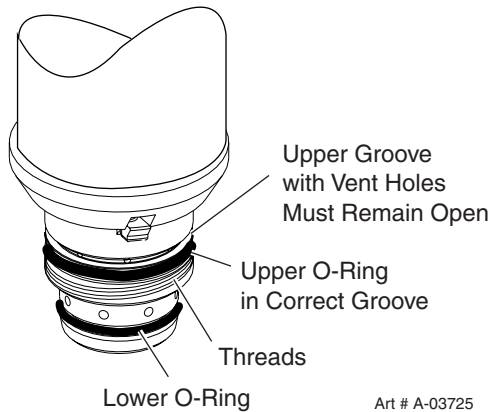

2. Torch start cartridge is stuck.
 - a) Turn off power supply. Bleed down the system. Remove the shield cup, tip, start cartridge and electrode. Check the lower end unit of the start cartridge for free movement. Replace the cartridge if the lower end unit does not move freely.

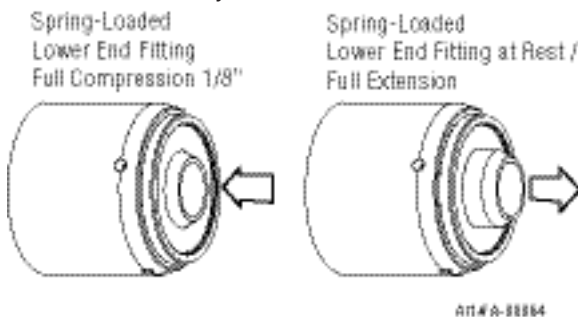

3. Worn or faulty torch parts
 - a) Inspect torch consumables parts. Replace if necessary.

4. Shorted Torch/leads
 - a) Disconnect torch from unit. With consumables removed from the torch, Check continuity of torch at ATC, between negative/plasma lead connection to pilot lead connection.

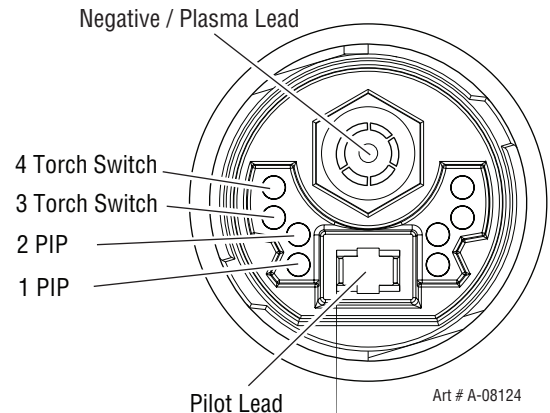

If a short is found, the problem is in the torch and leads assembly. Remove the torch head from the leads and check the leads and head to determine which is defective.

5. Low primary input power or missing phase
 - a) Measure primary input voltage between L1, L2 & L3 on W1 contactor under load.
6. Defective W1 contactor.
 - a) Check per section 5.11C.
 - b) Check voltage into and out of W1 contactor under load. Replace W1 if voltage drop is found.
7. Shorted Sync cable connected between J14 on Main Pcb 1 to J9 on 40A PCB 5.
 - a) Check continuity.
8. Open connection between J12 on Main PCB 1 to J1 on Capacitor PCB 2.
 - a) Check continuity.
9. Open connection between J2 on Capacitor PCB 2 to J3 on 40A PCB 5.
 - a) Check Continuity.
10. Open connection between J2 on Main PCB 1 to J1 on Logic PCB 3.
 - a) Check continuity.

11. Defective Logic PCB 3.
 - a) Measure Logic PCB 3 CUR_SET signal between J1-6 to TP1. If no voltage, replace PCB 3.
 - b) Measure Logic PCB 3 for SHDN signal between J1-10 to TP1. Normally 12vdc signal should drop to less than 1vdc when START signal is active. If voltage does not drop, replace PCB 3.
 - c) Measure Logic PCB 3 Signal /400_IN between J1--4 to TP1 for less than 2vdc.

If signal measures 12 VDC, replace the Logic PCB 3

12. Defective Main PCB 1.
 - a) Measure for approx 325vdc on Capacitor PCB 2 between MTH1 to MTH 7 under load. If voltage is not present replace PCB 1.
13. Defective Capacitor PCB 2.
 - a) Disconnect plug from J2 on Capacitor PCB 2 and measure between J2-1 to J2-2 for 12vdc. If voltage is low or zero, replace PCB 2.
14. Defective 40Amp PCB 5.
 - a) Isolate the 40A PCB 5 by disconnecting plug from J4, the Sync cable from J9 and the wire from terminal CHOKE1. Supply a START signal. If the FAULT is cleared, replace PCB 5.
15. Defective Main PCB 1.
 - a) Replace PCB 1.

C. SHORTED TORCH FAULT. FAULT indicator and 85 PSI LED are flashing at 5 cycles per second.

This mode is a non-latched mode.

1. While using an Automation Torch at current settings above 45 amps, the tip has contacted the work piece.
 - a) Check standoff height
2. Air restriction in torch resulting in low voltage during pilot.
 - a) Check torch consumables for wear or debris.
3. Low voltage during cutting due to torch or consumable problem.
 - a) Check torch consumables for wear or debris.

In all three cases, to reset the machine, remove the START signal.

D. AC LED on, TEMP LED off, GAS LED on, gas flowing, DC LED on, Fault Indicator off, No arc in torch.

1. Defective Main PCB 1.
 - a) Install jumper on Main PCB 1 between test point GND1 to terminal TIP1.
 - b) Apply START signal. If Pilot starts, replace Main PCB 1.

E. AC LED on, TEMP LED off, GAS LED on, gas flowing, DC LED on, Fault Indicator off, Pilot Arc is intermittent.

1. Defective Main contactor W1.
 - a) Check W1 per Pre Power-UP checks.
2. Defective Logic PCB 3
 - a) Measure for 12VDC on Main PCB between test Point GND1 to J2-8. If 12VDC is present, replace Logic PCB 3.
3. Defective Main PCB 1.
 - a) Replace Main PCB 1.

F. INTERNAL ERROR. Fault Indicator and 90 PSI Indicators are flashing.

1. There has been a microprocessor problem.
 - a) Turn ON/OFF SWITCH to OFF position and then turn to ON position to clear the error.
2. Defective Logic PCB 3.
 - a) Replace Logic PCB 3.

G. Fans MOT1-3 do not turn on after a START signal is activated.

1. Defective Logic PCB 3.
 - a) Measure voltage at J1-14 to J1-25 on Logic PCB 3 for 12VDC. The voltage should drop to less than 2vdc after a START signal is active. If the voltage remains at 12VDC replace the Logic PCB 3.

NOTE

When the unit is turned on the cooling fans MOT1-3 will remain off. (In earlier units MOT1

will turn on for .one (1) second and then turns off) The fans will turn on when a START signal (Torch Switch, Remote Pendant switch, or CNC START) is active and will remain on for ten (10) minutes after the START signal is removed. If an over temperature condition occurs, the fans will continue to run while the condition exists and for a ten (10) minute period after the condition is cleared.

2. Measure for 12VDC on the Logic PCB 3 between J7-1 to J7-1 after the START signal is activated. If voltage is not present replace Main PCB 1.

H. Fan MOT1 does not turn on after START signal is activated. (MOT2 & MOT3 do turn on)

1. Defective Main PCB 1
 - a) Turn SW1 to off position. Turn SW1 back to ON position and measure for 12VDC between J7-1 to J7-2 before START signal is activated. If no voltage is present, Replace Main PCB 1.
2. Defective MOT1
 - a) Check to be sure there is no physical obstructions preventing MOT1 fan blades from turning. Replace MOT1.

I. Either MOT2 or MOT3 do not turn on after START signal is activated.

1. Fan wires not connected to 40A PCB 5
 - a) Check and reconnect to 40A PCB 5.
2. Defective fan.
 - a) Check to be sure there is no physical obstructions preventing fan blades from turning. Replace respective fan.

J. Fans MOT2 & MOT3 do not turn on after START signal is activated.

1. Open connection between Main PCB 1 J13 to 40A PCB 5 J4.
 - a) Verify connectors are plugged in. Check continuity .
 - b) Measure voltage at J4-2 to J4-10 on 40AMP PCB 5 for 12VDC. The voltage should drop to less than 2vdc after a START signal is active. If the 12VDC is not present or does not drop to less than 2VDC after a START signal is activated, then replace the ribbon cable.
2. Defective 40AMP PCB 5
 - a) Measure the voltage between J1-1 to J1-2 on the 40AMP PCB 5 for 12VDC after the START

signal is activated. If 12VDC is present replace 40AMP PCB 5.

3. Defective Fans MOT2 and 3.
 - a) If 12VDC is resent on J1 and J2 connectors on 40A PCB 5, replace fans MOT2 & MOT3.

5.09 Main Arc and Controls Problems

A. Main arc will not establish, LED D59 on Main PCB remains on while pilot arc is striking the work piece.

1. Work Cable not connected.
 - a) Connect cable to work piece
2. Work cable open / broken.
 - a) Check continuity of work cable. Insure connection of cable to clamp is secure.

B. When Pilot Arc is brought to the work piece, the arc goes out immediately or extinguishes while cutting. ERROR indicator and 85 PSI indicator flashing.

- a) Ferrite filter on ribbon cable between J1 on Logic PCB 3 to J2 on Main PCB 1 is broken , loose or missing.
- b) Ferrite on wire harness between J13 connector on Main PCB 1 to J4 connector on 40A PCB 5 is broken, loose or missing.
- c) Wires SEC1 and SEC2 routed to close to component U2 on 40A PCB 5. Re-route to sspace a least 1 inch away.
- d) Older revision 40A PCB5. Replace if PCB 5 revision is "AC" or earlier.

C. Main arc transfers but current cannot be adjusted.

1. Defective Logic PCB 3.
 - a) While main arc is transferred,measure voltage on Main PCB between test points GND1 to I_DMD1.
 - b) Adjust CURRENT CONTROL POTENTIOMETER from maximum to minimum. Voltage should vary from 4VDC at max to 1 VDC at min

If voltage does not vary with CURRENT CONTROL POTENTIOMETER, Replace Logic PCB 3.

2. Defective Main PCB 1.
 - a) Replace Main PCB 1.

CUTMASTER 40MM

D. In LATCH mode, when the START signal is released the arc shuts off immediately.

1. Defective Logic PCB`3
 - a) Replace Logic PCB`3

E. With CURRENT CONTROL POTENTIOMETER set at maximum, output current is only 60 amps.

1. Tip is touching the work piece, Drag mode.
 - a) Lift tip off work piece
2. Defective Pilot IGBT on Main PCB 1
 - a) Check per section 4.10I
3. Open Sync cable between J14 on Main PCB 1 and 40Amp PCB 5.
 - a) Check continuity and replace if open..
4. Open connection between J13 on Main PCB 1 to J4 on 40A PCB 5.
 - a) Check continuity.
5. Defective 40Amp PCB 5.
 - a) Replace 40Amp PCB 5

G. In RAPID AUTO RESTART mode, with torch switch closed, the pilot does not start immediately when the cutting arc extinguishes

1. Defective Logic PCB 3
 - a) Replace Logic PCB 3

H. INTERNAL ERROR FAULT indicator and 90 PSI LED flashing

1. There has been a microprocessor problem.
 - a) Turn ON/OFF SWITCH to OFF position and then turn to ON position to clear the error
2. Defective Logic PCB 3.
 - a) Replace Logic PCB 3.

5.10 CNC Interface Problems

A. Nothing happens when jumper is installed between J2-3 to J2-4.

1. Defective Automation Interface PCB 4.
 - a) Measure voltage on PCB4 between J1-6 to J1-8 for 12VDC.

If 12VDC is present replace Automation Interface PCB 4

2. Defective Main PCB 1.
 - a) Measure voltage on Main PCB 1 between J1-6 to J1-8 for less than 2VDC.

If voltage is less than 2VDC, replace Main PCB`1.

B. No OK-TO-MOVE signal while cutting.

1. Defective Main PCB`1
 - a) Measure voltage on PCB4 between J1-1 to J1-3 for 12VDC while cutting.

If 12VDC is present, replace PCB 1

2. Defective Automation Interface PCB 4
 - a) Measure voltage on PCB 4 between J1-1 to J1-3 for less than 2VDC while cutting.

If voltage is less than 2VDC, replace PCB 4.

C. ARC VOLTS signals are low or not present

1. Defective Automation Interface PCB 4
 - a) Replace PCB`4

5.11 Test Procedures

A. Main Contactor (W1) Test

1. Check continuity between:
 - L1 to T1
 - L2 to T2
 - L3 to T3
 - L4 to T4

The contacts should be open – no continuity. If continuity is found, disconnect J1 from the Main PCB 1 and recheck. If continuity still exists, replace W1. If disconnecting J1 from Main PCB 1 removes the short, replace the Main PCB 1.

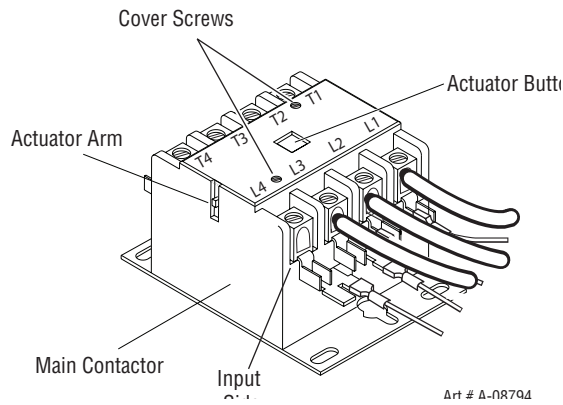

- Retest continuity between terminals while engaging the contacts manually. This can be done by pushing down on the recessed actuator button on the top of W1 or pushing down on the actuator arm on the side of W1.

- L1 to T1
- L2 to T2
- L3 to T3
- L4 to T4

The contacts should be closed – Continuity

- Visually check W1 contact points. To take the cover off, remove the two cover screws shown in the previous illustration. If contacts are stuck together or show excessive arcing or pitting, replace W1.

B. PCB 1 Input Diode D1 Test

- Using an ohmmeter perform the tests in the chart:

| Input Diode Module D1 on PCB1 | | |
|-------------------------------|-----------|-------------------------|
| Test points located on PCB 2 | | |
| Meter (+) | Meter (-) | Indication |
| 80A_AC1 | MTH 1 | Forward Biased Diode |
| 80A_AC2 | MTH 1 | Forward Biased Diode |
| 80A_AC3 | MTH 1 | Forward Biased Diode |
| MTH 1 | 80A_AC1 | Reverse Biase Diode |
| MTH 1 | 80A_AC2 | Reverse Biase Diode |
| MTH 1 | 80A_AC3 | Reverse Biase Diode |
| MTH 7 | 80A_AC1 | Forward Biased Diode |
| MTH 7 | 80A_AC2 | Forward Biased Diode |
| MTH 7 | 80A_AC3 | Forward Biased Diode |
| 80A_AC1 | MTH 7 | Reverse Biase Diode |
| 80A_AC2 | MTH 7 | Reverse Biase Diode |
| 80A_AC3 | MTH 7 | Reverse Biase Diode |
| MTH 7 | MTH 1 | 2 Forward Biased Diodes |

C. PCB 5 Input Diode D1 Test

- Using an ohmmeter perform the tests in the chart:

| Input Diode Module D1 on PCB5 | | |
|---------------------------------|-----------|-------------------------|
| Test points are located on PCB2 | | |
| Meter (+) | Meter (-) | Indication |
| 40A_AC1 | PMTH 1 | Forward Biased Diode |
| 40A_AC2 | PMTH 1 | Forward Biased Diode |
| 40A_AC3 | PMTH 1 | Forward Biased Diode |
| PMTH 1 | 40A_AC1 | Reverse Biase Diode |
| PMTH 1 | 40A_AC2 | Reverse Biase Diode |
| PMTH 1 | 40A_AC3 | Reverse Biase Diode |
| PMTH 4 | 40A_AC1 | Forward Biased Diode |
| PMTH 4 | 40A_AC2 | Forward Biased Diode |
| PMTH 4 | 40A_AC3 | Forward Biased Diode |
| 40A_AC1 | PMTH 4 | Reverse Biase Diode |
| 40A_AC2 | PMTH 4 | Reverse Biase Diode |
| 40A_AC3 | PMTH 4 | Reverse Biase Diode |
| PMTH 4 | PMTH 1 | 2 Forward Biased Diodes |

D. PCB 2 Capacitor / Relay Test

- Using an ohmmeter perform the tests in the chart:

| INPUT CAPACITORS | | |
|------------------|---------|------------|
| PCB 2 | | |
| Meter + | Meter - | Indication |
| MTH 2 | MTH 4 | Charging |
| MTH 8 | MTH 7 | Charging |

Most meters will show a charging action. Initially a low resistance will be shown and then the reststance will start to increase. If the meter probews are reversed the reading will decrease to zero, then start charging in the opposite polarity.

- Using an ohmmeter perform the tests in the chart:

| INPUT VOLTAGE SELECTION RELAYS | | |
|--------------------------------|---------|------------|
| PCB 2 | | |
| Meter + | Meter - | Indication |
| MTH 7 | MTH 4 | Charging |
| MTH 8 | MTH 2 | Charging |
| MTH 8 | MTH 4 | Charging |

CUTMASTER 40MM

E. PCB 1 IGBT Test

1. Disconnect transformer wire from PCB 2 Terminal PRI1 (A).
2. Using an ohmmeter check continuity between the following points:

| PCB 1 Q1 | | |
|------------------------------|-----------|--------------------|
| Test points located on PCB 2 | | |
| Meter (+) | Meter (-) | Indication |
| PRI 1 | MTH 2 | Forward Bias |
| PRI 1 | MTH 4 | Capacitor Charging |
| MTH 2 | PRI 1 | Capacitor Charging |
| MTH 4 | PRI 1 | Forward Bias |
| PRI 2 | MTH 2 | Forward Bias |
| PRI 2 | MTH 4 | Capacitor Charging |
| MTH 2 | PRI 2 | Capacitor Charging |
| MTH 4 | PRI 2 | Forward Bias |

3. Using an ohmmeter check continuity between the following points:

| PCB 1 Q2 | | |
|---------------------------------------|-----------|--------------------|
| Test points located on PCB 1* & PCB 2 | | |
| Meter (+) | Meter (-) | Indication |
| PRI 3* | MTH 8 | Forward Bias |
| PRI 3* | MTH 7 | Capacitor Charging |
| MTH 8 | PRI 3* | Capacitor Charging |
| MTH 7 | PRI 3* | Forward Bias |
| PRI 4* | MTH 8 | Forward Bias |
| PRI 4* | MTH 7 | Capacitor Charging |
| MTH 8 | PRI 4* | Capacitor Charging |
| MTH 7 | PRI 4* | Forward Bias |

F. PCB 5 IGBT Test

1. Disconnect transformer wires from 40 Amp PCB 5 terminal PRI 1 (A).
2. Using an ohmmeter perform the following checks:

| PCB 5 - Q1 | | |
|---|-----------|--------------------|
| Test points located on PCB 2 AND PCB 5* | | |
| Meter (+) | Meter (-) | Indication |
| PRI 1* | PMTH 1 | Forward Bias |
| PRI 1* | PMTH 2 | Capacitor Charging |
| PMTH 1 | PRI 1* | Capacitor Charging |
| PMTH 2 | PRI 1* | Forward Bias |
| PRI 2* | PMTH 1 | Forward Bias |
| PRI 2* | PMTH 2 | Capacitor Charging |
| PMTH 1 | PRI 2* | Capacitor Charging |
| PMTH 2 | PRI 2* | Forward Bias |

3. Disconnect transformer wire from 40 Amp PCB 5 terminal PRI4 (C).

4. Using an ohmmeter perform the following checks:

| PCB 5 – Q2 | | |
|---|-----------|--------------------|
| Test points located on PCB 2 AND PCB 5* | | |
| Meter (+) | Meter (-) | Indication |
| PRI 4* | PMTH 3 | Forward Bias |
| PRI 4* | PMTH 4 | Capacitor Charging |
| PMTH 3 | PRI 4* | Capacitor Charging |
| PMTH 4 | PRI 4* | Forward Bias |
| PRI 3* | PMTH 3 | Forward Bias |
| PRI 3* | PMTH 4 | Capacitor Charging |
| PMTH 3 | PRI 3* | Capacitor Charging |
| PMTH 4 | PRI 3* | Forward Bias |

G. PCB 1 Output Diode D3 Test

1. Disconnect transformer wires from Main PCB 1 terminal SEC1.
2. Using an ohmmeter perform the following checks:

| PCB 1 D3 | | |
|---|-----------|---------------|
| (Test points located on PCB 1* & PCB 2) | | |
| Meter (+) | Meter (-) | Indication |
| CHOKE1 | SEC1 | Forward Bias |
| CHOKE1 | SEC2 | Forward Bias |
| SEC1 | CHOKE1 | Reversed Bias |
| SEC2 | CHOKE1 | Reversed Bias |
| WORK1 | SEC1 | Reversed Bias |
| WORK1 | SEC2 | Reversed Bias |
| SEC1 | WORK1 | Forward Bias |
| SEC2 | WORK1 | Forward Bias |

H. PCB 5 Output Diode D2 Test

1. Disconnect transformer wires from Main PCB 5 terminal SEC1.
2. Using an ohmmeter perform the following checks:

| PCB 5 – D2 | | |
|------------------------------|-----------|---------------|
| Test points located on PCB 5 | | |
| Meter (+) | Meter (-) | Indication |
| CHOKE1 | SEC1 | Forward Bias |
| CHOKE1 | SEC2 | Forward Bias |
| SEC1 | CHOKE1 | Reversed Bias |
| SEC2 | CHOKE1 | Reversed Bias |
| +OUT_1 | SEC1 | Reversed Bias |
| +OUT_1 | SEC2 | Reversed Bias |
| SEC1 | +OUT_1 | Forward Bias |
| SEC2 | +OUT_1 | Forward Bias |

I. PCB 1 Pilot IGBT Test

1. Disconnect wire E35 from Main PCB 1 terminal TIP1.
2. Using a mutlimeter with a diode test scale, place the positive probe on PCB 1 terminal TIP1 and the negative probe on PCB 1 terminal WORK1. and check for a forward biased diode reading.
3. If the test reveals a failed component, replace Main PCB 1. If no problem is found, reconnect wire to Main PCB.

2. If the test reveals a failed component, replace Main PCB 1.

J. PCB 2 Capacitor / Relay Test (with PCB2 removed from the unit)

1. Using an ohmmeter perform the following checks::

| PCB 2 Capacitor & Relay Test | | |
|------------------------------|---------|------------|
| Meter + | Meter - | Indication |
| MTH 2 | MTH 4 | Charging |
| MTH 8 | MTH 7 | Charging |
| MTH 7 | MTH 4 | Open |
| MTH 8 | MTH 2 | Open |
| MTH 8 | MTH 4 | Open |

Most meters will show a charging action. Initially a low resistance will be shown and then the reststance will start to increase. If the meter probews are reversed the reading will decrease to zero, then start charging in the opposite polarity.

2. If test reveals a failed component, replace Capacitor PCB 2.

K. PCB 1 Input Diode Test. (With PCB 2 removed form unit)

1. Using an ohmmeter perform the following checks::

| Input Diode Module D1 on PCB1 | | |
|-------------------------------|-----------|-------------------------|
| Test points located on PCB 1 | | |
| Meter (+) | Meter (-) | Indication |
| AC1 | TP2 | Forward Biased Diode |
| AC2 | TP2 | Forward Biased Diode |
| AC3 | TP2 | Forward Biased Diode |
| TP2 | AC1 | Reverse Biase Diode |
| TP2 | AC2 | Reverse Biase Diode |
| TP2 | AC3 | Reverse Biase Diode |
| TP8 | AC1 | Forward Biased Diode |
| TP8 | AC2 | Forward Biased Diode |
| TP8 | AC3 | Forward Biased Diode |
| AC1 | TP8 | Reverse Biase Diode |
| AC2 | TP8 | Reverse Biase Diode |
| AC3 | TP8 | Reverse Biase Diode |
| TP8 | TP2 | 2 Forward Biased Diodes |

L. PCB 5 Input Diode Test. (With PCB 2 removed form unit)

1. Using an ohmmeter perform the following checks::

| Input Diode Module D1 on PCB5 | | |
|---------------------------------|-----------|-------------------------|
| Test points are located on PCB5 | | |
| Meter (+) | Meter (-) | Indication |
| AC1 | PMTH 1 | Forward Biased Diode |
| AC2 | PMTH 1 | Forward Biased Diode |
| AC3 | PMTH 1 | Forward Biased Diode |
| PMTH 1 | AC1 | Reverse Biase Diode |
| PMTH 1 | AC2 | Reverse Biase Diode |
| PMTH 1 | AC3 | Reverse Biase Diode |
| PMTH 4 | AC1 | Forward Biased Diode |
| PMTH 4 | AC2 | Forward Biased Diode |
| PMTH 4 | AC3 | Forward Biased Diode |
| AC1 | PMTH 4 | Reverse Biase Diode |
| AC2 | PMTH 4 | Reverse Biase Diode |
| AC3 | PMTH 4 | Reverse Biase Diode |
| PMTH 4 | PMTH 1 | 2 Forward Biased Diodes |

2. If the test reveals a failed component, replace 40A PCB 5.

CUTMASTER 40MM

M. PCB 1 IGBT Test. (With PCB 2 removed from unit)

- Using an ohmmeter perform the following checks::

| PCB 1 Q1 | | |
|------------------------------|-----------|----------------------|
| Test points located on PCB 1 | | |
| Meter (+) | Meter (-) | Indication |
| PRI 1 | TP1 | Forward Biased Diode |
| PRI 1 | TP5 | Reverse Biased Diode |
| TP1 | PRI 1 | Reverse Biased Diode |
| TP5 | PRI 1 | Forward Biased Diode |
| PRI 2 | TP1 | Forward Biased Diode |
| PRI 2 | TP5 | Reverse Biased Diode |
| TP1 | PRI 2 | Reverse Biased Diode |
| TP5 | PRI 2 | Forward Biased Diode |

| PCB 1 Q2 | | |
|------------------------------|-----------|----------------------|
| Test points located on PCB 1 | | |
| Meter (+) | Meter (-) | Indication |
| PRI 3 | TP4 | Forward Biased Diode |
| PRI 3 | TP8 | Reverse Biased Diode |
| TP4 | PRI 3 | Reverse Biased Diode |
| TP8 | PRI 3 | Forward Biased Diode |
| PRI 4 | TP4 | Forward Biased Diode |
| PRI 4 | TP8 | Reverse Biased Diode |
| MTH 8 | TP4 | Reverse Biased Diode |
| MTH 7 | TP8 | Forward Biased Diode |

- If the test reveals a failed component, replace Main PCB 1.

N. PCB 5 IGBT Test. (With PCB 2 removed from unit)

- Using an ohmmeter perform the following checks::

| PCB 5 - Q1 | | |
|------------------------------|-----------|----------------------|
| Test points located on PCB 5 | | |
| Meter (+) | Meter (-) | Indication |
| PRI 1 | PMTH 1 | Forward Biased Diode |
| PRI 1 | PMTH 2 | Reverse Biased Diode |
| PMTH 1 | PRI 1 | Reverse Biased Diode |
| PMTH 2 | PRI 1 | Forward Biased Diode |
| PRI 2 | PMTH 1 | Forward Biased Diode |
| PRI 2 | PMTH 2 | Reverse Biased Diode |
| PMTH 1 | PRI 2 | Reverse Biased Diode |
| PMTH 2 | PRI 2 | Forward Biased Diode |

| PCB 5 – Q2 | | |
|------------------------------|-----------|----------------------|
| Test points located on PCB 5 | | |
| Meter (+) | Meter (-) | Indication |
| PRI 4 | PMTH 3 | Forward Biased Diode |
| PRI 4 | PMTH 4 | Reverse Biased Diode |
| PMTH 3 | PRI 4 | Reverse Biased Diode |
| PMTH 4 | PRI 4 | Forward Biased Diode |
| PRI 3 | PMTH 4 | Forward Biased Diode |
| PRI 3 | PMTH 3 | Reverse Biased Diode |
| PMTH 4 | PRI 3 | Reverse Biased Diode |
| PMTH 3 | PRI 3 | Forward Biased Diode |

- If the test reveals a failed component, replace 40Amp PCB 5.

NOTE

Many of the signals listed in the PCB information to follow will be low voltage signals that will be in one of two states: +12VDC (High) or 0VDC (Low) with respect to pcb common.. When a signal name is preceded by the "/" mark, it denotes that the signal is an active low. For example:

/OVERTEMP – This signal is normally High but when an over temperature fault exists, this line will change state to a Low.

5.12 Main PCB Layout & Signals

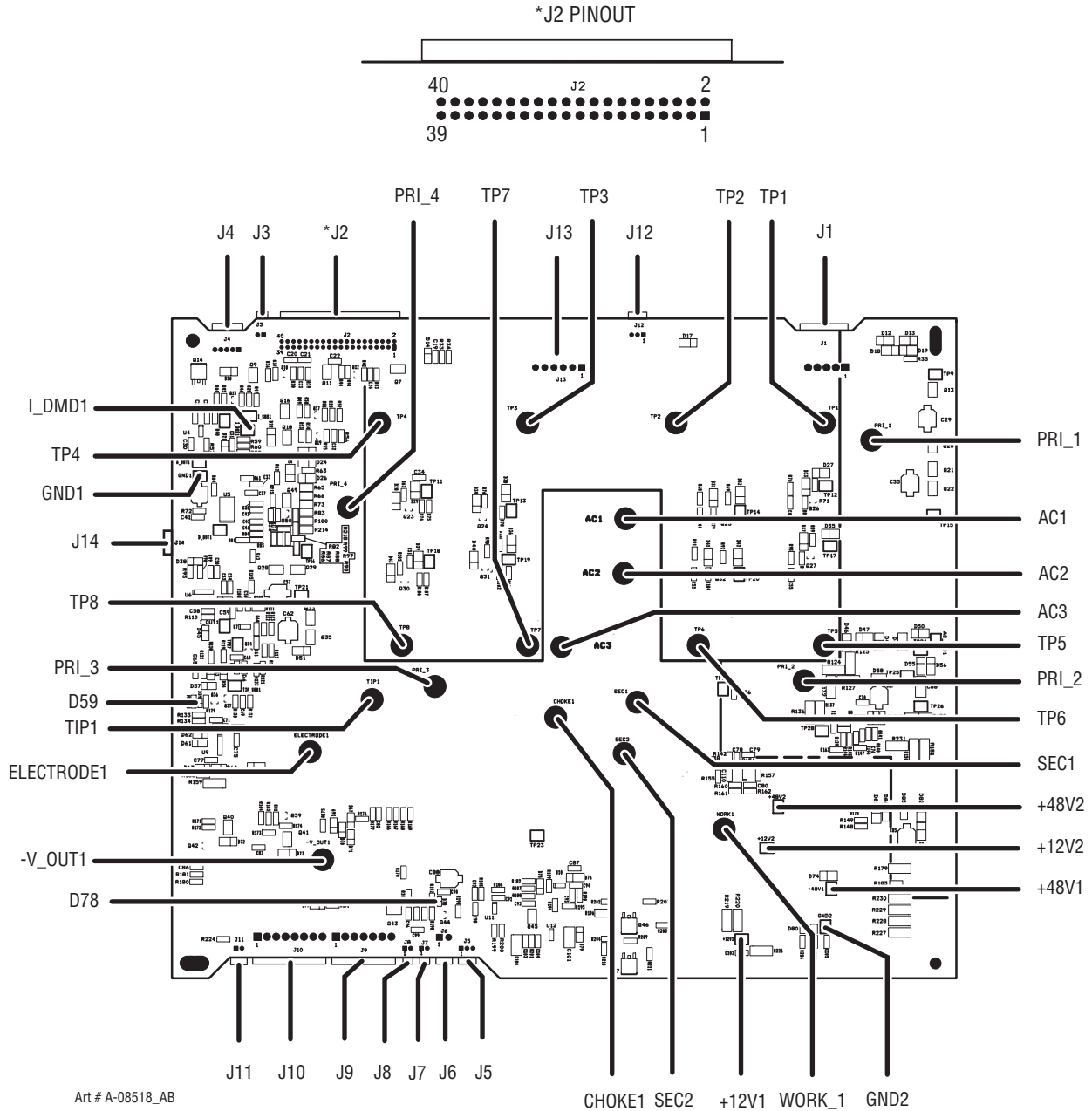

MAIN PCB 1 LAYOUT

A. MAIN PCB 1 SIGNALS

- J1-1 L1 Primary AC Line
- J1-2 Not used
- J1-3 Not used
- J1-4 Not used
- J1-5 L2 Primary AC Line

| | | | Signal Source/Destination |
|-------|---------------------|---|---------------------------|
| J2-1 | -VOUT | (-) OUTPUT VOLTAGE | M-L |
| J2-2 | /TIP VOLTS | Active high when tip is installed | M-L |
| J2-3 | TIP_SEN | Approx. 100VDC while cutting w/ tip off work, Active low in Drag Mode | M-L |
| J2-4 | /400V_IN | Active low with 400vac primary input voltage | L-M |
| J2-5 | N/A | | |
| J2-6 | CUR_SET | Current demand signal. Variable 1-4VDC | L-M |
| J2-7 | /RAR | Active low when in Rapid Auto Restart mode | L-M |
| J2-8 | /INRUSH | Active low after inrush time expires | L-M |
| J2-9 | /W1_ON | Active low to enable W1 contactor | L-M |
| J2-10 | SHDN | Active low enables PWM circuit | |
| J2-11 | /TRCH_SOL | Active low to enable Torch Solenoid | L-M |
| J2-12 | /SOL_ON | Active low to enable Power Supply solenoid | L-M |
| J2-13 | /OK_TO_MOVE | Active low to enable OK_TO_MOVE (CNC) | L-M |
| J2-14 | /FAN_ON | Active low to enable fans | L-M |
| J2-15 | /LATCH_ACTIVE | Active low when Latch mode is active during cut | L-M |
| J2-16 | /TRCH_SW | Active low = START is active -Torch switch, CNC | M-L |
| J2-17 | /PIP | Active low = PARTS IN PLACE satisfied | M-L |
| J2-18 | AC_ON | Pulse signal | M-L |
| J2-19 | CSR | Active high during main transfer | M-L |
| J2-20 | /TORCH_SOL_DETECTED | Active low for torch with remote solenoid | M-L |
| J2-21 | /OVERTEMP | Active low when over temperature | M-L |
| J2-22 | V_IN | Input Voltage signal 2.6VDC = 400 VAC | M-L |
| J2-23 | +12VDC | | M-L |
| J2-24 | +12VDC | | M-L |
| J2-25 | GND | | M-L |
| J2-26 | GND | | M-L |
| J2-27 | Not Used | | |
| J2-28 | Not Used | | |
| J2-29 | MAIN_BD_ID | Voltage level to identify Main Pcb = 1.1VDC | M-L |
| J2-30 | Not Used | | |
| J2-31 | Not Used | | |
| J2-32 | Not Used | | |
| J2-33 | Not Used | | |
| J2-34 | For Factory Use | | M-L |
| J2-35 | +3.3VDC | | M-L |
| J2-36 | TXD | | M-L |
| J2-37 | RXD | | L-M |
| J2-38 | Common | | M-L |
| J2-39 | D | | M-L |
| J2-40 | Not Used | | |

CUTMASTER 40MM

| | |
|-------|---|
| J3-1 | N/A |
| J3-2 | Common |
| J4-1 | 3.3VDC |
| J4-2 | TXD |
| J4-3 | RXD |
| J4-4 | Common |
| J4-5 | D |
| J5-1 | +12VDC |
| J5-2 | Not used |
| J5-3 | /SOLENOID |
| J6-1 | 24VAC Supply for W1 |
| J6-2 | 24VAC Return |
| J7-1 | +12VDC |
| J7-2 | /FAN |
| J8 | Not Used |
| J9-1 | /PIP |
| J9-2 | Common |
| J9-3 | /TORCH SWITCH (START) |
| J9-4 | Common |
| J9-5 | Automation Torch solenoid 24VAC supply |
| J9-6 | Not Used |
| J9-7 | Automation Torch solenoid 24VAC return |
| J10-1 | /OK-TO-MOVE |
| J10-2 | Not used |
| J10-3 | /OK-TO-MOVE |
| J10-4 | Not used |
| J10-5 | Common |
| J10-6 | Common |
| J10-7 | +12VDC |
| J10-8 | /START (Remote Pendant / CNC Signal) |
| J11 | N/A |
| J12-1 | +12VDC |
| J12-2 | /400VAC |
| J12-3 | N/AC |

| | |
|-------|-------------|
| J13-1 | /OVERTEMP |
| J13-2 | /FAN_ON |
| J13-3 | /CSR |
| J13-4 | CUR_SET |
| J13-5 | MAIN_PCB_ID |
| J13-6 | Common |

B. MAIN PCB 1 LED INDICATORS

D59 PCR Indicates Pilot IGBT gate signal is on
D78 CSR Indicates cutting arc has been established

C. MAIN PCB 1 TEST POINTS

| | |
|------------|--|
| +12V1 | +12VDC |
| +12V2 | +12VDC |
| +48V1 | +48VDC |
| +48V2 | +48VDC |
| AC1 | AC Input |
| AC2 | AC Input |
| AC3 | AC Input |
| CHOKE1 | Negative DC output to L1 |
| ELECTRODE1 | Negative DC output to torch |
| GND1 | Common |
| GND2 | Common |
| I_DMD1 | Current Demand Signal 1.5VDC during Pilot 1.2-4 VDC During Cut |
| PRI_1 (A) | IGBT Bank A Output to T1 |
| PRI_2 (B) | IGBT Bank A Output to T1 |
| PRI_3 (D) | IGBT Bank B Output to T1 |
| PRI_4 (C) | IGBT Bank B Output to T1 |
| SEC1 | T1 Secondary |
| SEC2 | T1 Secondary |
| TP1 | Capacitor Bank A + |
| TP2 | Capacitor Bank A+ |
| TP3 | Capacitor Bank B+ |
| TP4 | Capacitor Bank B+ |
| TP5 | Capacitor Bank A- |
| TP6 | Capacitor Bank A- |
| TP7 | Capacitor Bank B- |
| TP8 | Capacitor Bank B- |
| TIP1 | Positive Tip DC Output |
| -V_OUT1 | Negative DC output |
| WORK1 | Positive DC output |

This Page Intentionally Blank

5.13 Capacitor PCB Layout & Signals

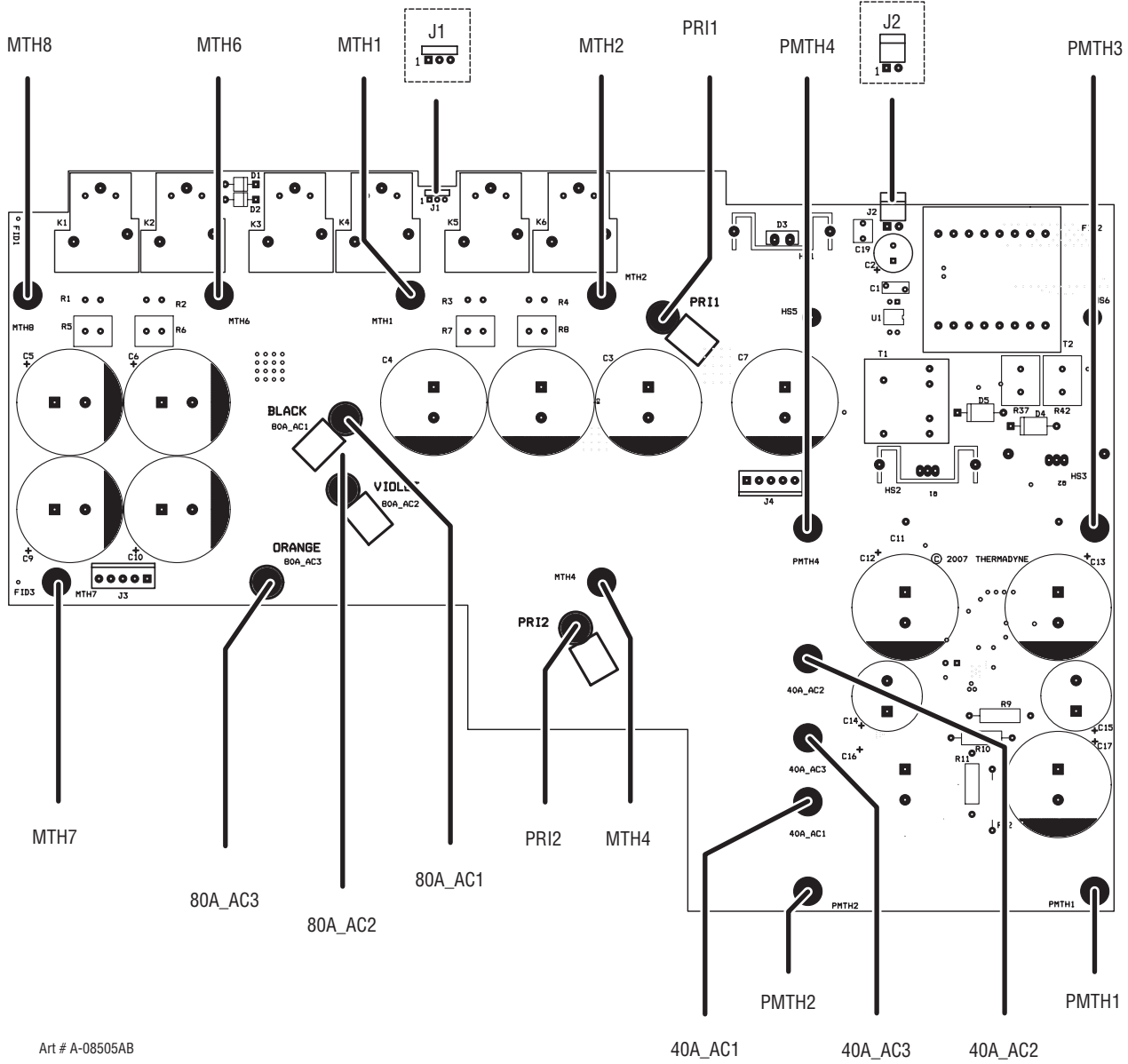

CAPACITOR PCB 2 LAYOUT

A. CAPACITOR PCB 2 SIGNALS

| | |
|------|---------|
| J1-1 | +12vdc |
| J1-2 | /400VAC |
| J1-3 | N/A |
| J2-1 | +12VDC |
| J2-2 | Common |

B. CAPACITOR PCB 2 TEST POINTS

| | |
|---------|--------------|
| MTH1 | CAP BANK A + |
| MTH2 | CAP BANK A+ |
| MTH4 | CAP BANK A- |
| MTH6 | CAP BANK B+ |
| MTH7 | CAP BANK B- |
| MTH8 | CAP BANK B+ |
| PMTH1 | CAP BANK A+ |
| PMTH2 | CAP BANK A- |
| PMTH3 | CAP BANK B+ |
| PMTH4 | CAP BANK B- |
| 80A_AC1 | AC line 1 |
| 80A_AC2 | AC line 2 |
| 80A/AC3 | AC line 3 |
| 40A_AC1 | AC line 1 |
| 40A_AC2 | AC line 2 |
| 40A/AC3 | AC line 3 |

5.14 Logic PCB Layout & Signals

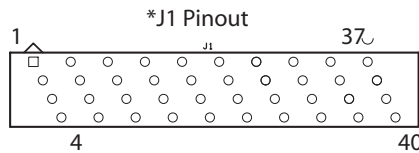
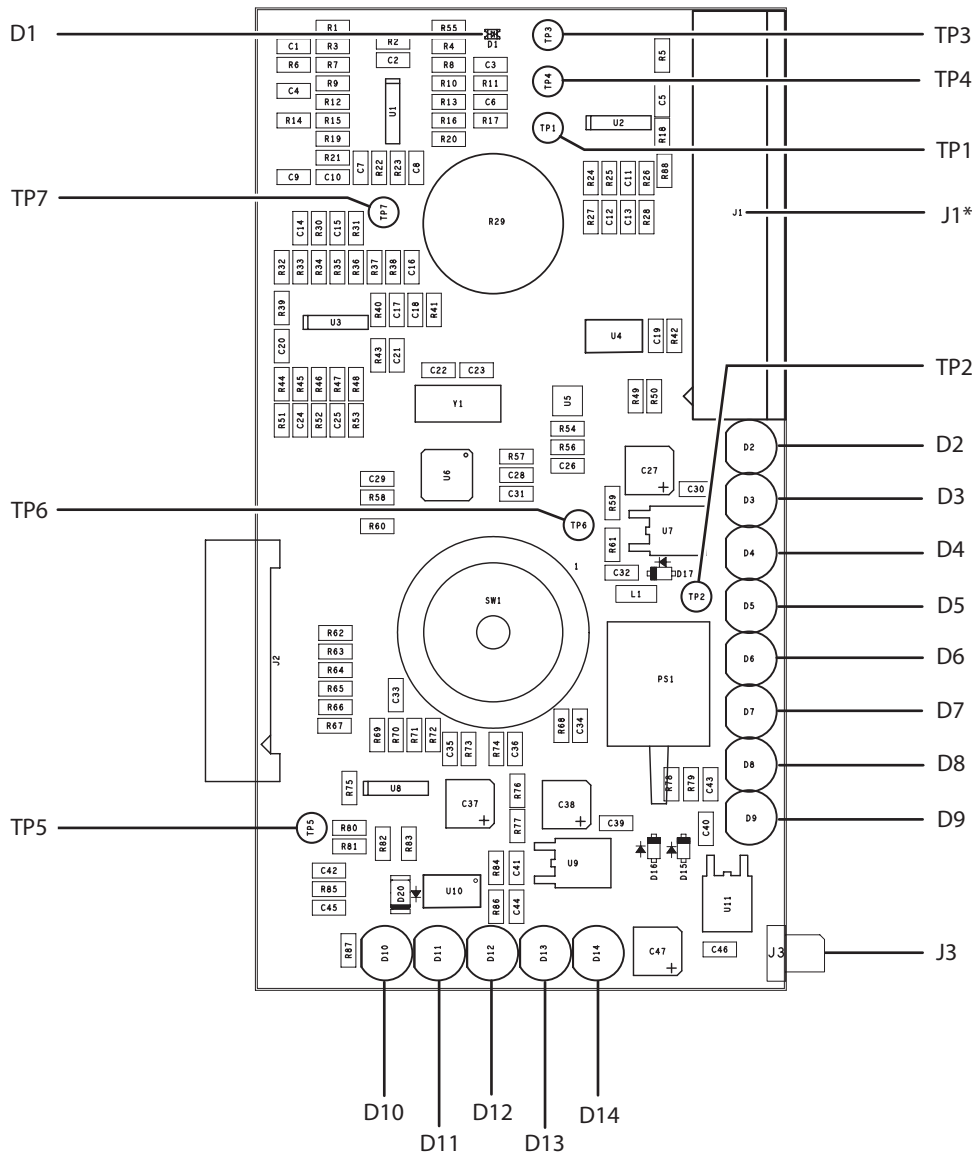

Art # A-08504_AB

LOGIC PCB 3 LAYOUT

A. LOGIC PCB 3 SIGNALS

- J1 Signal info is the same as MAIN PCB 1 J2 connector.
- J3-1 +5VDC
- J3-2 Pressure Transducer output 0.5 to 5 VDC / 0 - 100 psi
- J3-3 Common

B. LOGIC PCB 3 LED INDICATORS

| NORMAL INDICATION | FIRMWARE VERSION | ERROR MESSAGE |
|--------------------------|-------------------------|--|
| D1 | +12VDC | |
| D2 | MAX PRESSURE | X.7 Over Pressure |
| D3 | 90 PSI | X.6 Internal Error |
| D4 | 85 PSI | X.5 Shorted torch (Output Fault) |
| D5 | 80 PSI | X.4 Tip Missing |
| D6 | 75 PSI | X.3 Start Signal active during power up |
| D7 | 70 PSI | X.2 Parts-In-Place Fault (PIP) |
| D8 | 65 PSI | X.1 Input Power Fault |
| D9 | MIN PRESSURE | X.0 Low Pressure |
| D10 | AC | 1.X |
| D11 | OVERTEMP | 2.X |
| D12 | GAS | 3.X |
| D13 | DC | 4.X |
| D14 | ERROR | 5.X |

C. LOGIC PCB 3 TEST POINTS

| | |
|-----|---------------------------------------|
| TP1 | Common |
| TP2 | +12VDC |
| TP3 | +5VDC |
| TP4 | +3.3DCV |
| TP5 | 0.5 to 5 VDC / 0 - 100 psi |
| TP6 | +1.8VDC |
| TP7 | Potentiometer Current Demand (0-3.3V) |

5.15 40AMP Logic PCB Layout & Signals

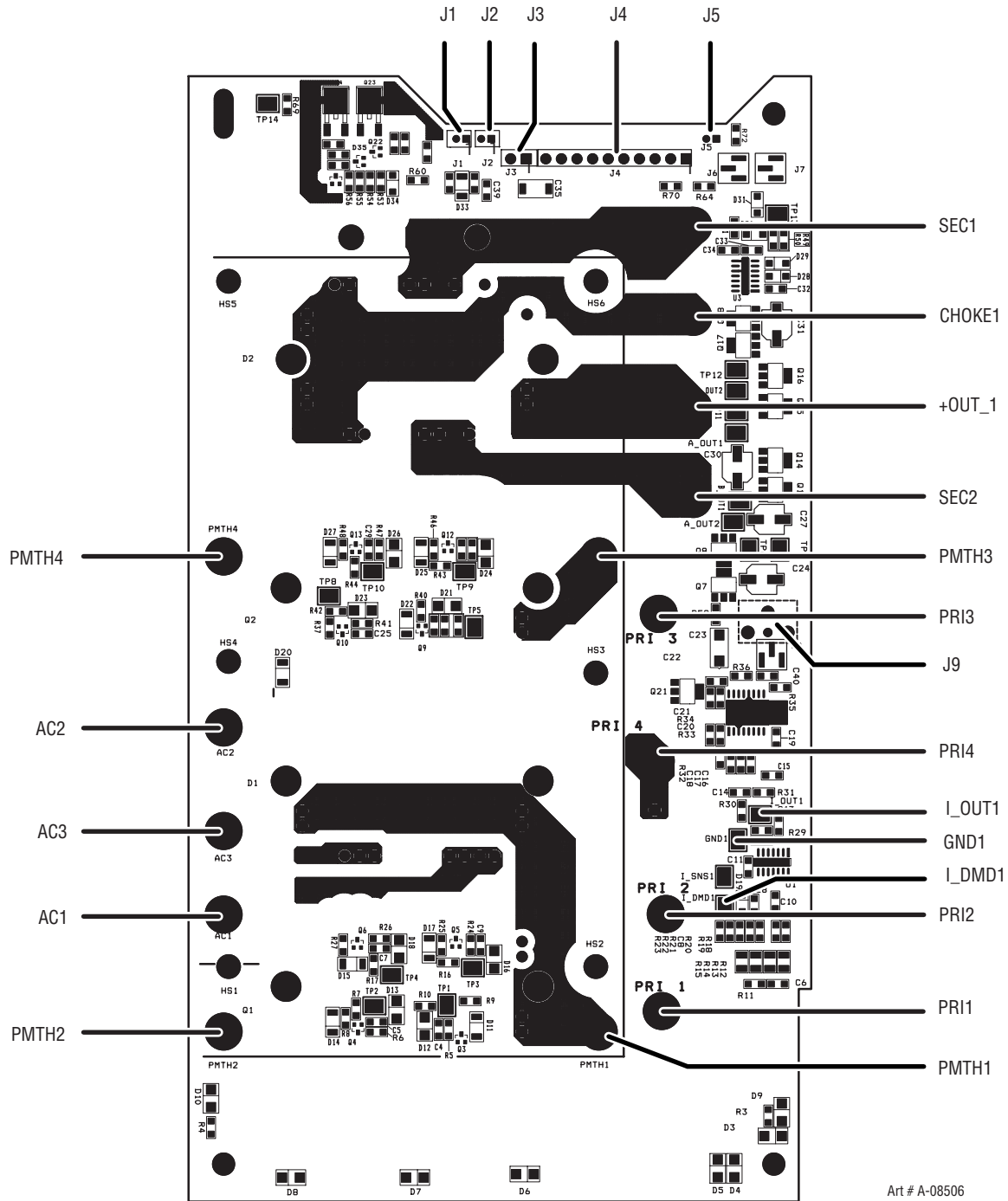

40AMP PCB 5 LAYOUT

A. 40AMP PCB 5 SIGNALS

| | | | |
|-------|-------------|---------------------------------|---------------------------|
| J1-1 | +12VDC | Supply for Fan MOT2 | |
| J1-2 | /FAN | Active Low to enable Fan MOT2 | |
| J2-1 | +12VDC | Supply for Fan MOT3 | |
| J2-2 | /FAN | Active Low to enable Fan MOT3 | |
| | | | Signal Source/Destination |
| J3-1 | +12VDC | +12VDC Supply | C/40A |
| J3-2 | Common | +12VDC Return | C/40A |
| J4-4 | /OVERTEMP | Active Low signal when OVERTEMP | 40A-M |
| J4-5 | /FAN_ON | Active Low to enable Fans | M-/40A |
| J4-6 | /CSR | Active low to Enable PWM | M/40A |
| J4-7 | CUR_SET | 1.2 -4VDC Cut Current Demand | M-/40A |
| J4-8 | MAIN_PCB_ID | 0 Ohms to common | 40A/M |
| J4-9 | Not Used | | |
| J4-10 | Common | | 40A/M |

B. TEST POINTS

| | |
|---------|-------------------|
| 80A_AC1 | AC Input Phase 1 |
| 80A-AC2 | AC Input Phase 2 |
| 80A_AC3 | AC Input Phase 3 |
| 40A_AC1 | AC Input Phase 1 |
| 40A-AC2 | AC Input Phase 2 |
| 40A_AC3 | AC Input Phase 3 |
| MTH1 | Capacitor Bank A+ |
| MTH2 | Capacitor Bank A+ |
| MTH4 | Capacitor Bank A- |
| MTH6 | Capacitor Bank B+ |
| MTH7 | Capacitor Bank B- |
| MTH8 | Capacitor Bank B+ |
| PMTH1 | Capacitor Bank A+ |
| PMTH2 | Capacitor Bank A- |
| PMTH3 | Capacitor Bank B+ |
| PMTH4 | Capacitor Bank B- |

CUTMASTER 40MM

5.16 Right Side Wiring Diagram

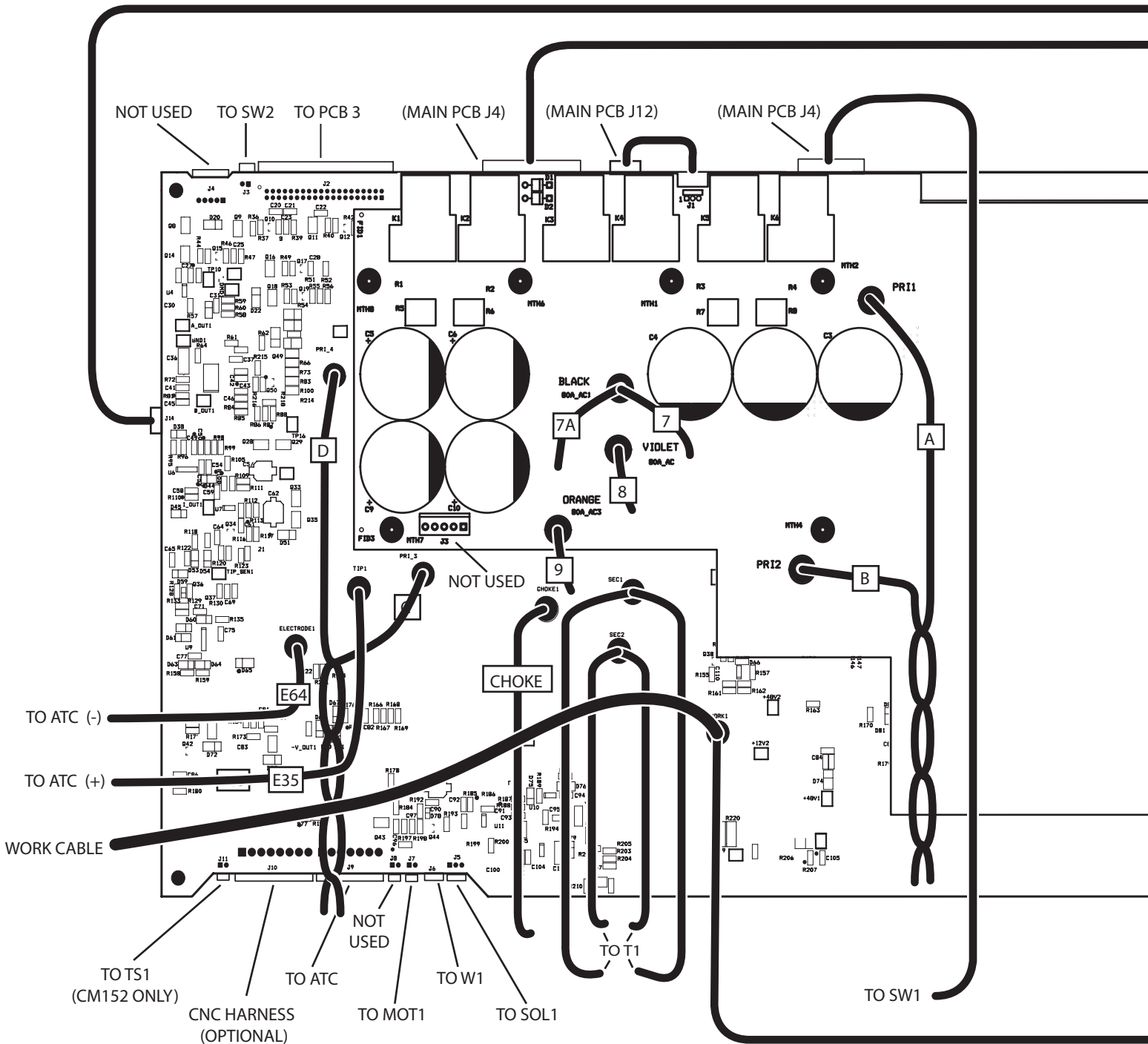

Art # A-08620_AA

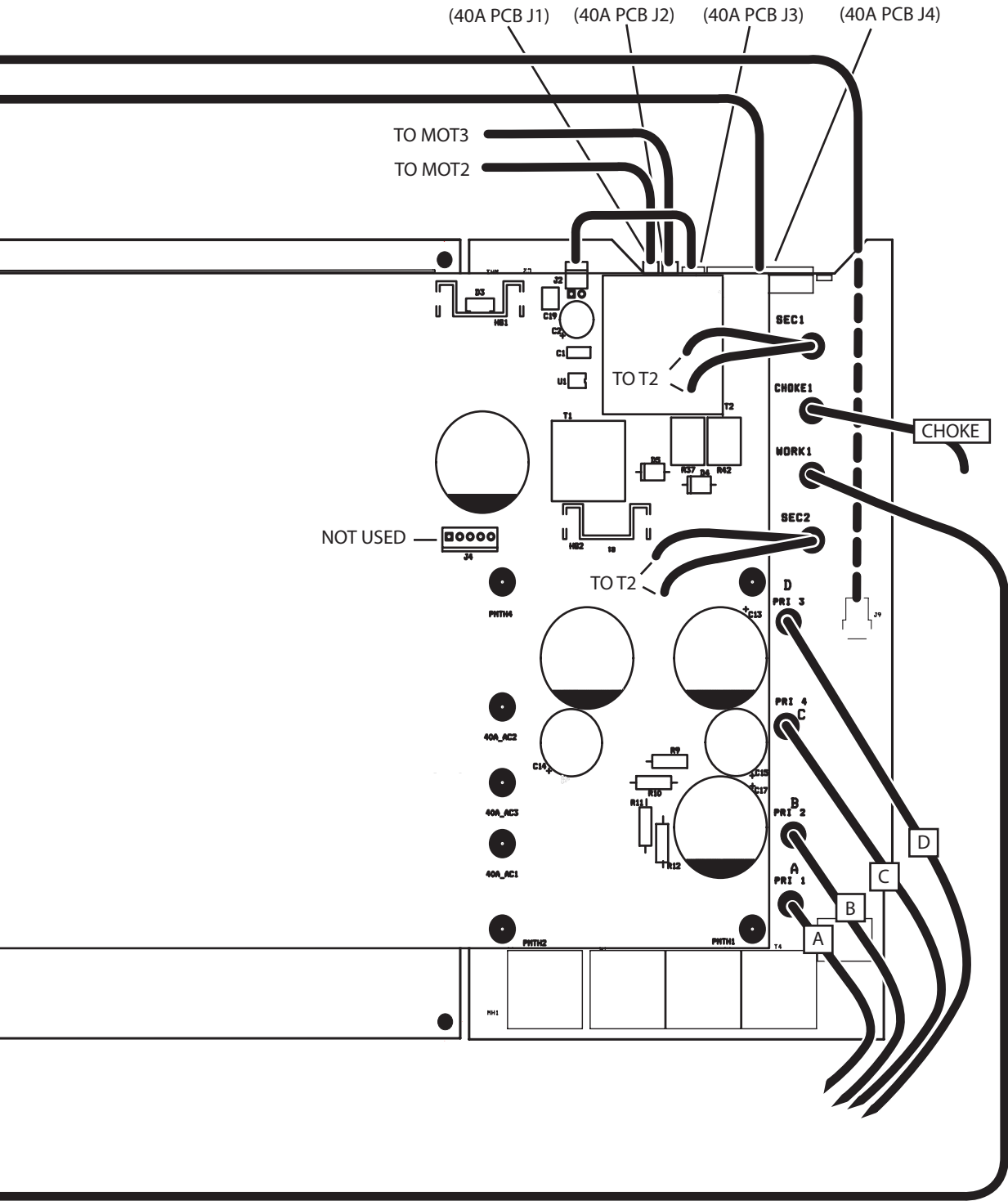

Art # A-08620_AA

This Page Intentionally Blank

SECTION 5 TORCH: SERVICE

It is recommended to apply a very light film of o-ring lubricant (Catalog # 8-4025) to the o-rings on a weekly basis.

5T.01 General Maintenance

NOTE

Refer to Previous "Section 5 System" for common and fault indicator descriptions.

Cleaning Torch

Even if precautions are taken to use only clean air with a torch, eventually the inside of the torch becomes coated with residue. This buildup can affect the pilot arc initiation and the overall cut quality of the torch.



WARNINGS

Disconnect primary power to the system before disassembling the torch or torch leads.

DO NOT touch any internal torch parts while the AC indicator light of the Power Supply is ON.

The inside of the torch should be cleaned with electrical contact cleaner using a cotton swab or soft wet rag. In severe cases, the torch can be removed from the leads and cleaned more thoroughly by pouring electrical contact cleaner into the torch and blowing it through with compressed air.



CAUTION

Dry the torch thoroughly before reinstalling.

O-Ring Lubrication

An o-ring on the Torch Head and ATC Male Connector requires lubrication on a scheduled basis. This will allow the o-rings to remain pliable and provide a proper seal. The o-rings will dry out, becoming hard and cracked if the lubricant is not used on a regular basis. This can lead to potential performance problems.

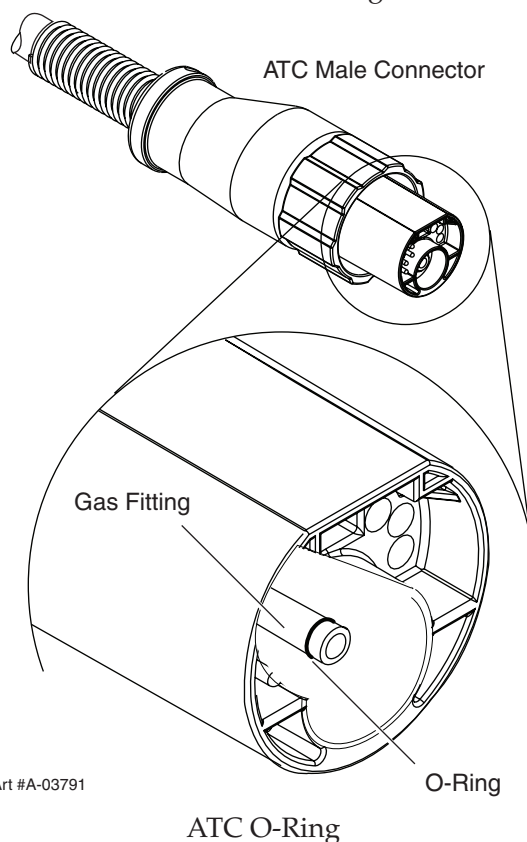
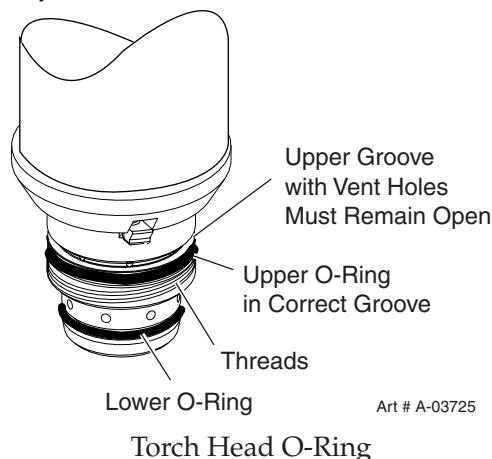

NOTE

DO NOT use other lubricants or grease, they may not be designed to operate within high temperatures or may contain "unknown elements" that may react with the atmosphere. This reaction can leave contaminants inside the torch. Either of these conditions can lead to inconsistent performance or poor parts life.

5T.02 Inspection and Replacement of Consumable Torch Parts



WARNINGS

Disconnect primary power to the system before disassembling the torch or torch leads.

DO NOT touch any internal torch parts while the AC indicator light of the Power Supply is ON.

Remove the consumable torch parts as follows:

NOTE

The shield cup holds the tip and starter cartridge in place. Position the torch with the shield cup facing upward to prevent these parts from falling out when the cup is removed.

1. Unscrew and remove the shield cup from the torch.

NOTE

Slag built up on the shield cup that cannot be removed may effect the performance of the system.

2. Inspect the cup for damage. Wipe it clean or replace if damaged.

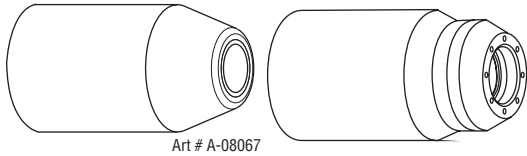

Shield Cups

3. On torches with a shield cup body and a shield cap or deflector, ensure that the cap or deflector is threaded snugly against the shield cup body. In shielded drag cutting operations (only), there may be an O-ring between the shield cup body and drag shield cap. Do not lubricate the O-ring.

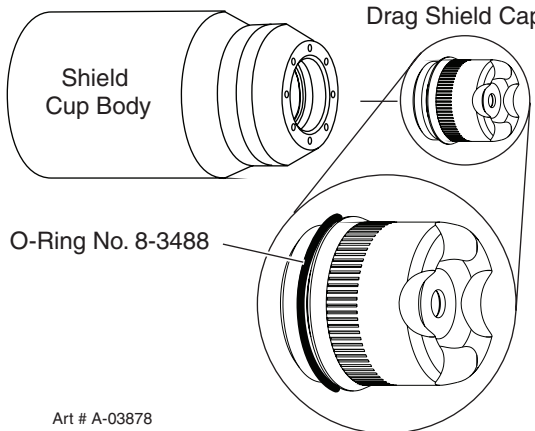

Art # A-03878

4. Remove the tip. Check for excessive wear (indicated by an elongated or oversized orifice). Clean or replace the tip if necessary.

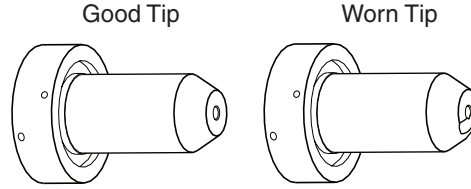

A-03406

Example of Tip Wear

5. Remove the starter cartridge. Check for excessive wear, plugged gas holes, or discoloration. Check the lower end fitting for free motion. Replace if necessary.

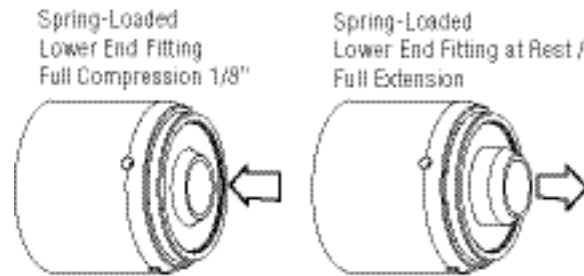

Art # A-88864

6. Pull the Electrode straight out of the Torch Head. Check the face of the electrode for excessive wear. Refer to the following figure.

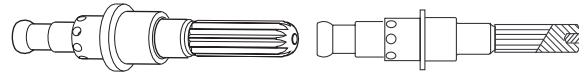

New Electrode

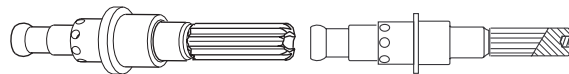

Worn Electrode

Art # A-03284

Electrode Wear

7. Reinstall the Electrode by pushing it straight into the torch head until it clicks.
8. Reinstall the desired starter cartridge and tip into the torch head.
9. Hand tighten the shield cup until it is seated on the torch head. If resistance is felt when installing the cup, check the threads before proceeding.

This completes the parts replacement procedures.

SECTION 6: PARTS LISTS

6.01 Introduction

A. Parts List Breakdown

The parts list provide a breakdown of all replaceable components. The parts lists are arranged as follows:

- Section 6.03 Complete Power Supply Replacement
- Section 6.04 Major External Replacement Parts
- Section 6.05 Front Panel Replacement Parts
- Section 6.06 Left Side Replacement Parts
- Section 6.07 Right Side Replacement Parts
- Section 6.08 Options and Accessories
- Section 6.09 Replacement Parts for Hand Torch
- Section 6.10 Replacement Parts - for Machine Torches with Unshielded Leads
- Section 6.11 Torch Consumable Parts (SL100)

NOTE

Parts listed without item numbers are not shown, but may be ordered by the catalog number shown.

B. Returns

If a product must be returned for service, contact your distributor. Materials returned without proper authorization will not be accepted.

6.02 Ordering Information

Order replacement parts by catalog number and complete description of the part or assembly, as listed in the parts list for each type item. Also include the model and serial number of the power supply. Address all inquiries to your authorized distributor.

6.03 Power Supply Replacement

The following items are included with the replacement power supply: work cable & clamp, input power cable, gas pressure regulator / filter, and operating manual.

| Qty | Description | Catalog # |
|-----|--|-----------|
| 1 | CutMaster 40mm CE Power Supply with 380/400/415VAC, 3 phase input power cable | 3-1930-3 |
| 1 | CutMaster 40mm Non CE Power Supply with 380/400/415VAC, 3 phase input power cable | 3-1930-4 |

CUTMASTER 40mm

6.04 Major External Replacement Parts

| Item # | Qty | Description | Catalog # |
|--------|-----|-------------------------|-----------|
| 1 | 1 | Cover with labels | 9-0224 |
| 2 | 1 | Base Enclosure Assembly | 9-0186 |
| 3 | 1 | Tube, roll handle | 9-0121 |
| 4 | 1 | Front Panel | 9-0230 |
| 5 | 1 | Rear Panel | 9-0101 |

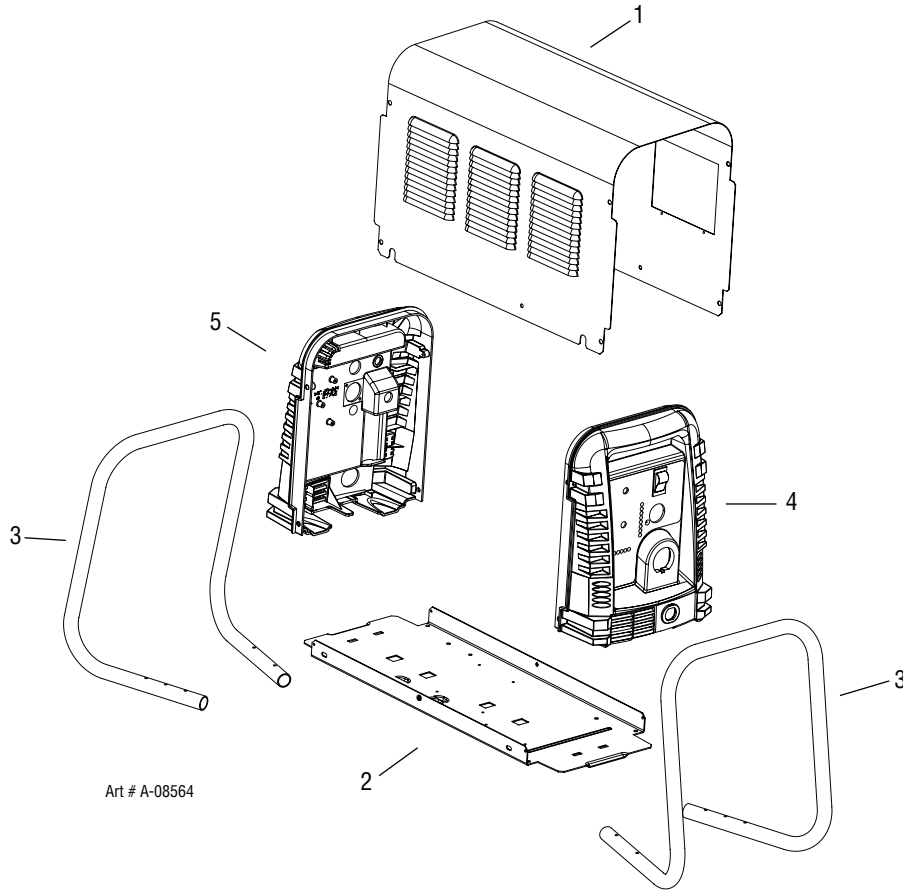

NOTE

Illustration may vary slightly from unit.

6.05 Front Panel Replacement Parts

| Item# | Qty | Description | Ref. | Catalog # |
|------------|-----|--|------|-----------|
| 1 | 1 | Output Current Control and Function Control Knobs | | 9-8527 |
| 2 | 1 | Toggle - On/Off Switch | SW1 | 9-0109 |
| 3 | 1 | Work Cable with Clamp, 20 Ft / 6.1 m | | 9-0189 |
| Not Shown: | 1 | Wire harness (from SW1) w/EMI Choke (CE Power Supplies Only) | | 9-0247 |

**NOTE**

Illustration may vary slightly from unit.

CUTMASTER 40mm

6.06 Left Side Replacement Parts

| Item # | Qty | Description | Ref | Catalog # |
|------------|-----|---|--------|-----------|
| 1 | 1 | Main PCB Assembly | PCB1 | 9-0125 |
| 1b | 1 | Main PCB Assembly 50 Amp | PCB5 | 9-0203 |
| 2 | 1 | Logic PCB | PCB3 | 9-0107* |
| 3 | 1 | Center Chassis Molded Plastic | | 9-0190 |
| 4 | 1 | Fan, (3 total) | MOT1-3 | 9-0232 |
| 5 | 1 | Transformer, Main | T1 | 9-0106 |
| 5b | 1 | Transformer, Main 60 Amp | T2 | 9-0196 |
| 6 | 1 | Inductor, Output | L1 | 9-0105 |
| 6b | 1 | Inductor, Output 40 Amp | L2 | 9-0195 |
| Not Shown: | | | | |
| | 1 | Clamp-On Wire Harness Ferrite Filter -(On Logic Pcb Ribbon Cable) | | 9-0249 |

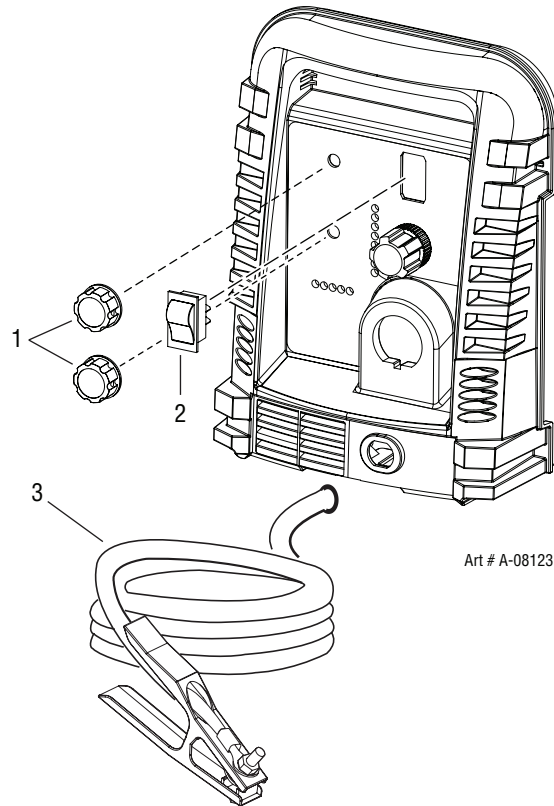
NOTE

*9-0107 Logic PCB3, If the Logic pcb has a pcb mounted pressure transducer with a small hose connecting the transducer to a fitting on the regulator assembly, then kit number 9-0201, which includes both a new Logic pcb and regulator assembly, will need to be ordered

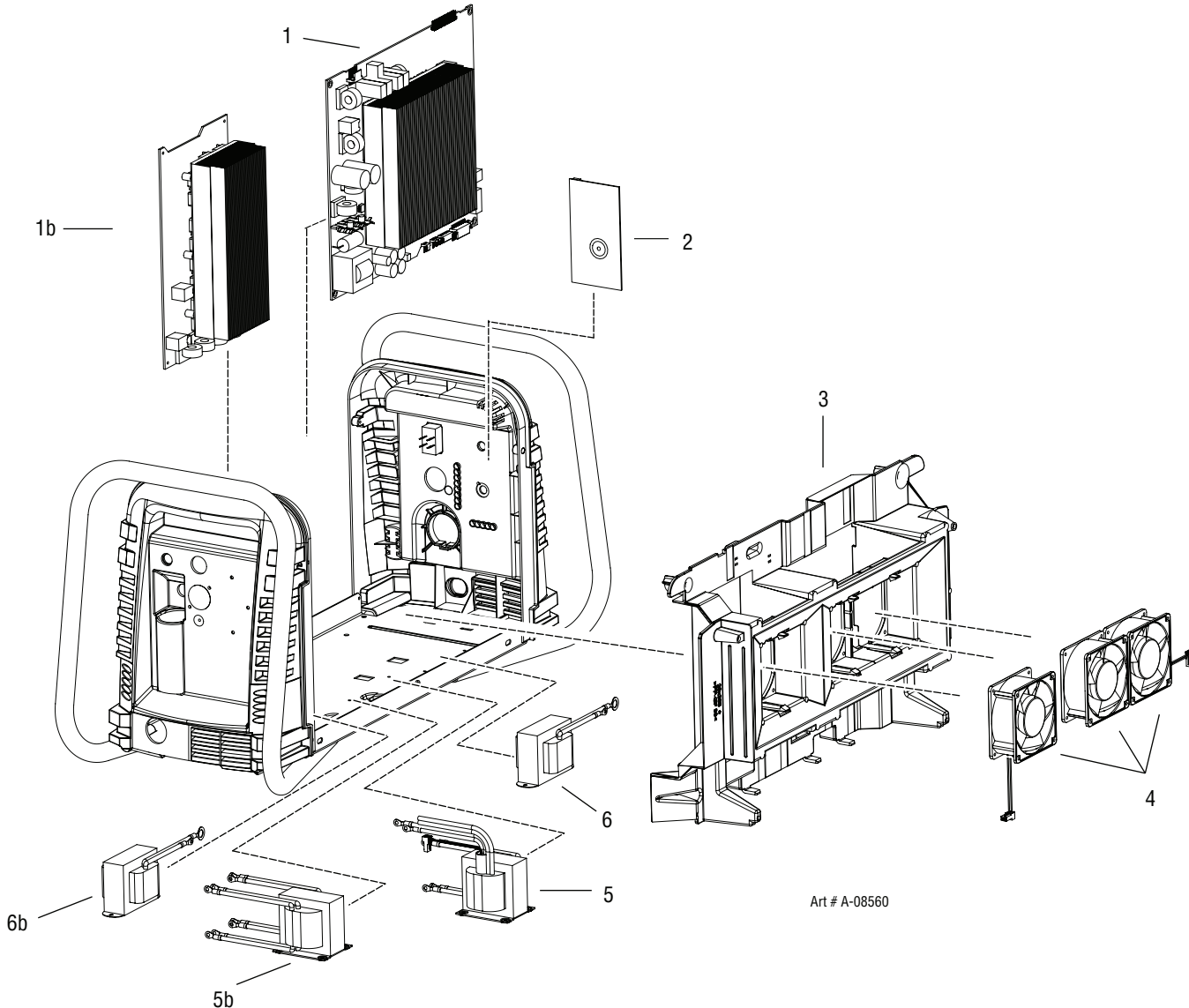

6.07 Right Side Replacement Parts

| Item # | Qty | Description | Ref | Catalog # |
|--------|-----|---|------|-----------|
| 1 | 1 | Contactora, 4 Pole | W1 | 9-8587 |
| 2 | 1 | Solenoid, 12V | SOL1 | 9-0114 |
| 3 | 1 | Spare Parts Box | | 7-3267 |
| 4 | 1 | Spare Parts Box Cover | | 7-3266 |
| 5 | 1 | Console Quick Disconnect | | 9-0161 |
| 6 | 1 | Regulator, with knob and mounting nut | | 9-0115* |
| 7 | 1 | Assembly, PCB, Input Capacitors | PCB2 | 9-0202 |
| 8 | 1 | Filter, Auto Drain | | 9-0116 |
| 9 | 1 | 3 Phase Input Line EMI Filter (CE Power Supplies Only)) | | 9-0253 |

Not Shown:

| | | | | |
|---|--|---|--|--------|
| 1 | | Power Cable Strain Relief, all units (Kit includes both styles) | | 9-0111 |
| 1 | | Input Power Cable 380/400/415 V 3 phase | | 9-0216 |

NOTE:

**9-0115 regulator, If the Logic pcb has a pcb mounted pressure transducer with a small hose connecting the transducer to a fitting on the regulator assembly, then kit number 9-0201, which includes both a new Logic pcb and regulator assembly, will need to be ordered.*

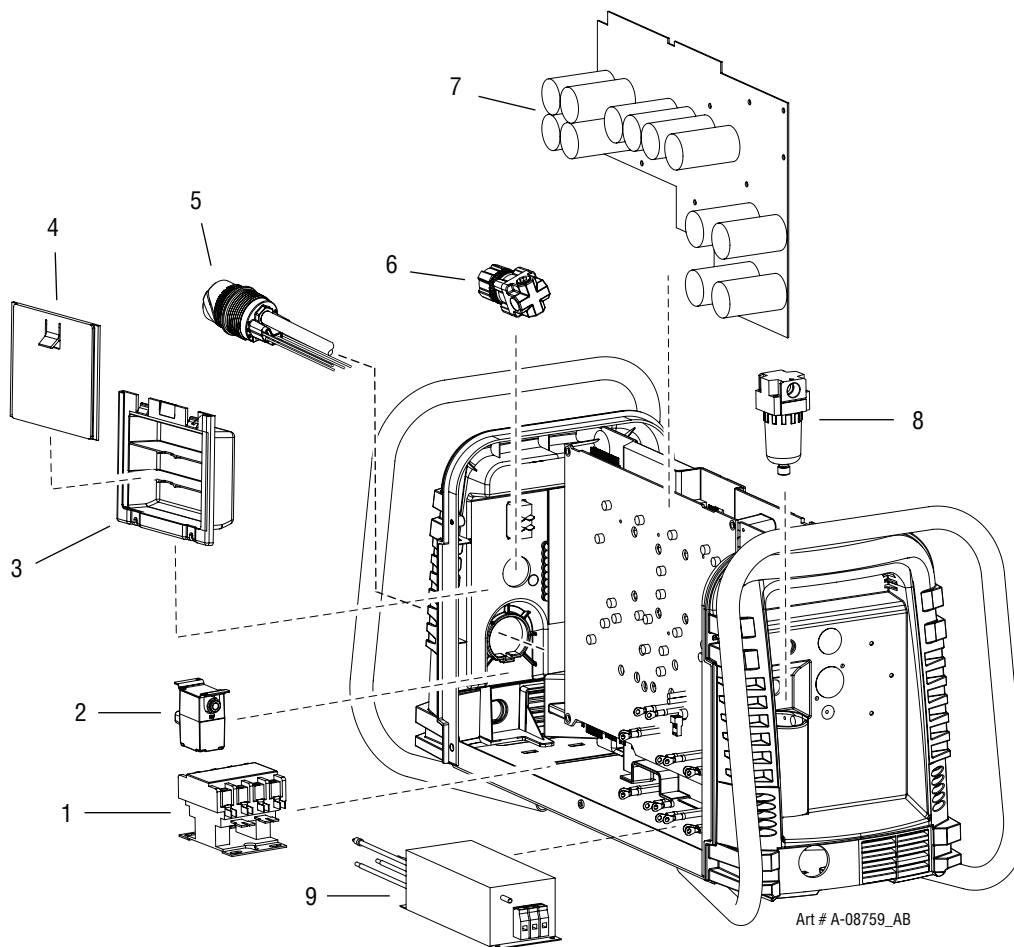

NOTE

Illustration may vary slightly from unit.

6.08 Options and Accessories

| Qty | Description | Ref. | Catalog # |
|-----|---|------|-----------|
| 1 | Single - Stage Filter Kit (includes Filter & Hose) | | 7-7507 |
| 1 | Replacement Filter Body | | 9-7740 |
| 1 | Replacement Filter Hose (not shown) | | 9-7742 |
| 2 | Replacement Filter Element | | 9-7741 |
| 1 | Two - Stage Filter Kit (includes Hose, Bracket & Mounting Screws) | | 9-9387 |
| 1 | Bracket, Filter Mounting (not shown) | | 9-9386 |
| 1 | Two - Stage Air Filter Assembly | | 9-7527 |
| 1 | First Stage Cartridge | | 9-1021 |
| 1 | Second Stage Cartridge | | 9-1022 |
| 1 | Extended Work Cable (50 ft / 15.2 m) with Clamp | | 9-8529 |
| 1 | Automation Interface Kit | PCB4 | 9-8311 |
| 1 | Automation Harness | | 9-9385 |
| 1 | 25' / 7.6 m CNC Cable for Automation Interface Kit | | 9-8312 |
| 1 | 50' /15.2 m CNC Cable for Automation Interface Kit | | 9-8313 |

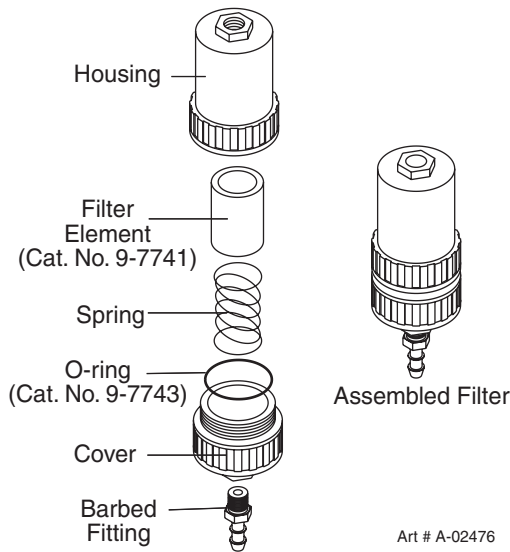

Optional Single - Stage Filter Kit

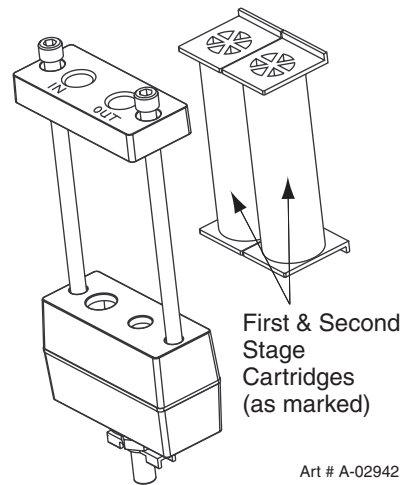

Optional Two - Stage Filter Kit

6.09 Replacement Parts for Hand Torch

| Item # | Qty | Description | Catalog # |
|--------|-----|---|-----------|
| 1 | 1 | Torch Handle Replacement Kit (includes items No. 2 & 3) | 9-7030 |
| 2 | 1 | Trigger Assembly Replacement Kit | 9-7034 |
| 3 | 1 | Handle Screw Kit (5 each, 6-32 x 1/2" cap screw, and wrench) | 9-8062 |
| 4 | 1 | Torch Head Assembly Replacement Kit (includes items No. 5 & 6) | 9-8219 |
| 5 | 1 | Large O - Ring | 8-3487 |
| 6 | 1 | Small O - Ring | 8-3486 |
| 7 | | Leads Assemblies with ATC connectors (includes switch assemblies) | |
| | 1 | SL100, 20 - foot Leads Assembly with ATC connector | 4-7836 |
| | 1 | SL100 , 50 - foot Leads Assembly with ATC connector | 4-7837 |
| 8 | 1 | Switch Kit (2 total) | 9-7031 |

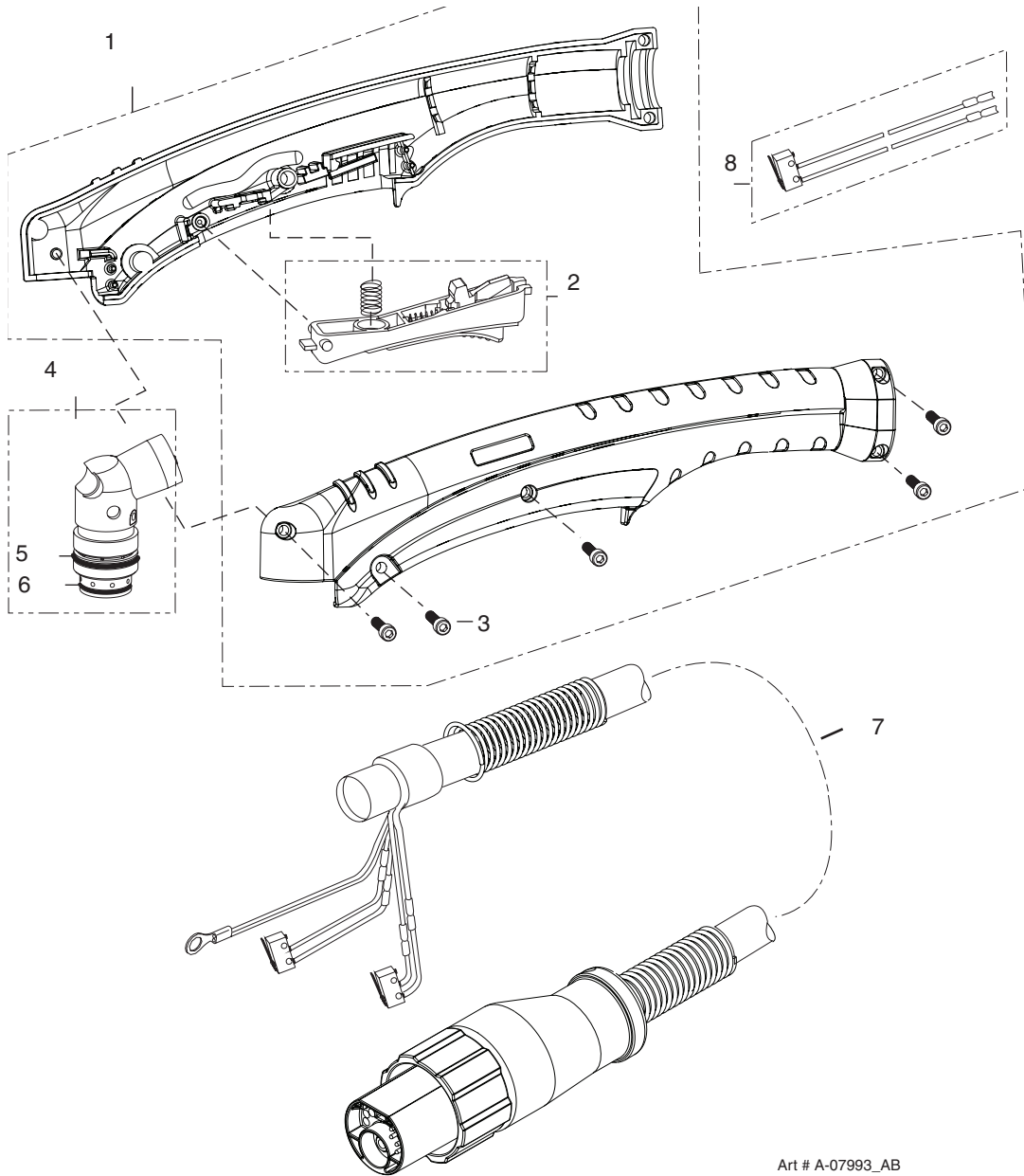

Art # A-07993_AB

CUTMASTER 40mm

6.10 Replacement Parts - for Machine Torches with Unshielded Leads

| Item No. | Qty | Description | Catalog No. |
|----------|-----|---|-------------|
| 1 | 1 | Torch Head Assembly without leads (includes items 2, 3, and 14) | 9-8220 |
| 2 | 1 | Large O - Ring | 8-3487 |
| 3 | 1 | Small O - Ring | 8-3486 |
| 4 | 1 | PIP Switch Kit | 9-7036 |
| 5 | | Unshielded Mechanized Leads Assemblies with ATC connectors | |
| | 1 | 5 - foot / 1.5 m Leads Assembly with ATC connector | 4-7842 |
| | 1 | 10 - foot / 3.05 m Leads Assembly with ATC connector | 4-7843 |
| | 1 | 25 - foot / 7.6 m Leads Assembly with ATC connector | 4-7844 |
| | 1 | 50 - foot / 15.2 m Leads Assembly with ATC connector | 4-7845 |
| 6 | 1 | 11" / 279 mm Rack | 9-7041 |
| 7 | 1 | 11" / 279 mm Mounting Tube | 9-7043 |
| 8 | 1 | End Cap Assembly | 9-7044 |
| 9 | 2 | Body, Mounting, Pinch Block | 9-4513 |
| 10 | 1 | Pin, Mounting, Pinch Block | 9-4521 |
| 11 | 1 | Torch Holder Sleeve | 7-2896 |
| 12 | 1 | PIP Plunger and Return Spring Kit | 9-7045 |
| | 1 | Pinion Assembly (Not shown) | 7-2827 |
| | 1 | 5" / 126 mm Positioning Tube (Not shown) | 9-7042 |

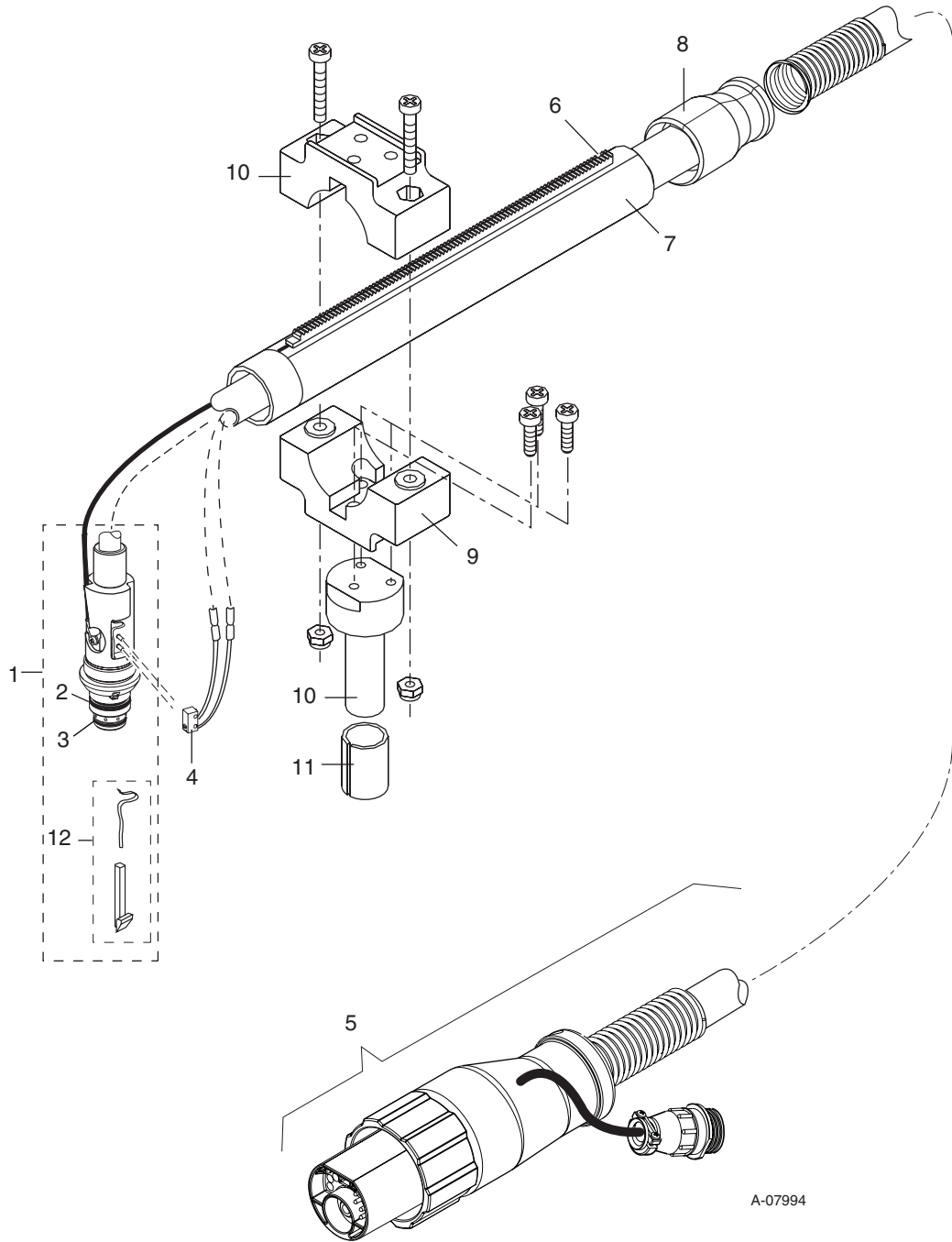

A-07994

CUTMASTER 40mm

6.11 Torch Consumable Parts (SL100 SV)

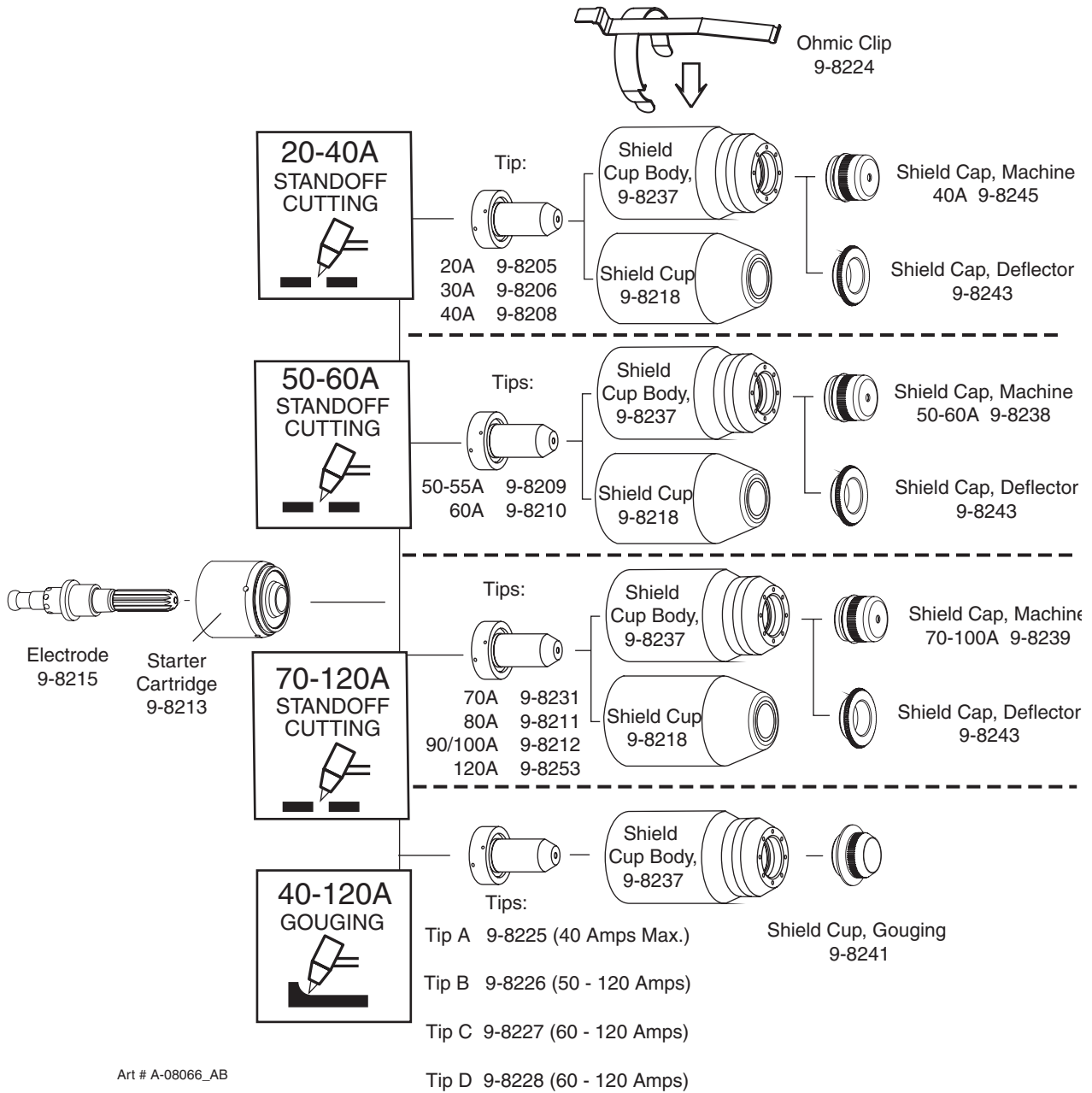

Art # A-08066_AB

SECTION 7: REPLACEMENT PROCEDURES

7.01 Scope

This section describes parts replacement procedures which may be performed on the CutMaster 40mm Power Supply.

Under no circumstances are field repairs to be attempted on Printed Circuits or other subassemblies of this unit. Evidence of unauthorized repairs may void the factory warranty.

7.02 Anti-Static Handling Procedures

A. General



Caution

PC Boards can be irreparably damaged by improper handling due to electrostatic discharge (ESD).

Replacement PC Boards are shipped in a protective enclosure to prevent damage from electrostatic discharge (ESD) during shipping. A ground strap is included with each replacement board to prevent static damage during installation.



WARNINGS

Read and understand these instructions and the instructions on the grounding wrist strap package before opening the equipment enclosure or removing the replacement PC board from its protective enclosure.

Disconnect primary power to the system before disassembling the torch, torch leads, or power supply enclosure.

Where these instructions include specific torquing instructions, failure to torque properly will cause component damage.

Do not operate the equipment or test equipment under power while wearing the grounding wrist strap.

B. Procedure

1. Open the wrist strap and unwrap the first two folds of the band. Wrap the adhesive side firmly around your wrist.
2. Unroll the rest of the band and peel the liner from the copper foil at the opposite end.
3. Attach the copper foil to a convenient and exposed electrical ground.
4. Connect the equipment primary cable ground to the same electrical ground as the wrist strap.
5. Open the equipment enclosure and remove the failed PC board.
6. Carefully open the ESD protective bag and remove the replacement PC Board.
7. Install the replacement PC Board in the equipment and make all necessary connections.
8. Place the failed PC Board in the ESD protective bag and seal for return shipping.
9. Replace the power supply cover.
10. Remove the grounding wrist strap from your wrist and from the electrical ground connection before reconnecting primary power to the equipment.

7.03 Parts Replacement - General Information

The parts replacement procedures described in this manual, except for filter replacement, require that the Power Supply be disassembled. The part to be replaced will determine to what extent the Power Supply must be disassembled.

Before removing any connection mark each wire with the connection designation. When reassembling make sure the wires go to the proper terminals.

Note the routing of wires and make sure the wires are put back in the same place when re-assembling the unit.

Each subsection is referenced to Section 6 for parts lists and overall detailed drawings.



WARNING

Disconnect primary power from the source before opening or disassembling the power supply.

7.04 Major External Parts

A. Cover Removal

Tools required: T20 Torx Driver

1. Remove the upper and lower screws which secure the cover to the main assembly. Do not loosen the lower screws inside the cut out slots in the bottom of the cover.

Note

The upper screws and lower screws are not the same. Do not mix them. The upper screws are for threading into the plastic of the front and rear panels. DO NOT use the finer threaded lower screws for this.

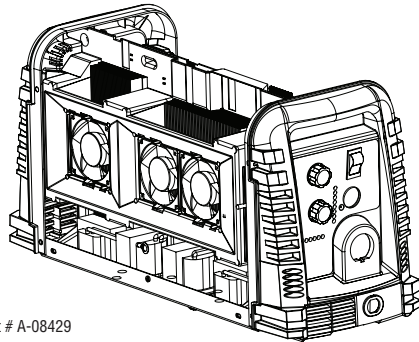
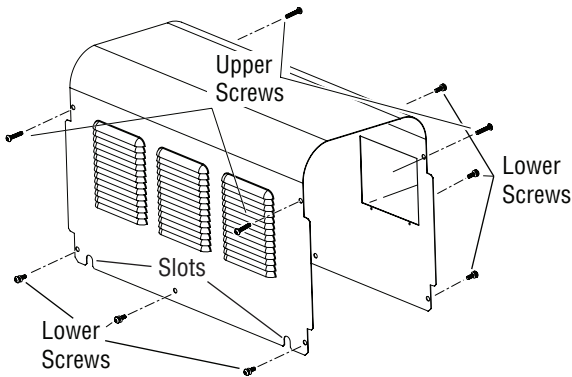

2. Carefully pull the Cover up and away from the unit.

B. Cover Installation

1. Reverse previous procedures for cover installation.

NOTE

When installing the upper screws, attempt to reuse the original threads. The easiest way to do this is by turning the screw counter-clockwise until you feel the threads line up, then begin to turn the screw clockwise to tighten. Do not over tighten.

C. Tube Handle Replacement

Tools required: T20 Torx Driver

1. Remove the cover per subsection 7.04 A.
2. Remove the screws securing the tube handles to the base of the unit.
3. Remove the Tube Handles.
4. Replace the Tube Handles by reversing the above steps.
5. Reinstall the power supply cover.

D. Disconnecting Front and Rear Panels from the base

In many of the replacement procedures, it may be helpful to disconnect the front or rear panel from the base in order to allow more room to access the parts.

Tools required: T20 Torx Driver

1. Remove the cover per subsection 7.04 A.
2. While grasping the panel close to the base, pull the panel directly from the base to release the locking tabs.
3. To re-engage the panel, position the panel so that the locking tabs are above the base, then push the panel back onto the base until the locking tabs engage the mating holes in the base.
4. For complete removal of panel, disconnect any other item still attached to the panel and another component of the power supply.

7.05 Front Panel Parts Replacement

Refer to section 6.05 for Front Panel Replacement Parts and overall detailed drawing.

A. Current Control Potentiometer (A) Knob Replacement

Tools required: Flat Screw Driver

1. Turn the potentiometer fully clockwise and note the location of the pointer mark on the knob.
2. Loosen the screw securing the Current Control Knob to the potentiometer shaft and remove the knob.
3. Replace the knob on the potentiometer shaft with the pointer in the same position as noted in step 1.

B. Function Control Switch Knob Replacement

Tools required: Flat Screw Driver

1. Turn the Function Control Switch until the pointer on the knob is in the LATCH position.
2. Loosen the screw securing the knob to the switch shaft and remove the knob.
3. Replace the knob on the switch shaft with the pointer in the position noted in step 1.

C. Replacing Gas Hoses

Tools required: T20 Torx Driver

1. Remove the cover per subsection 7.04A
2. Push the gas fitting locking ring back. A small open end wrench works well for this.

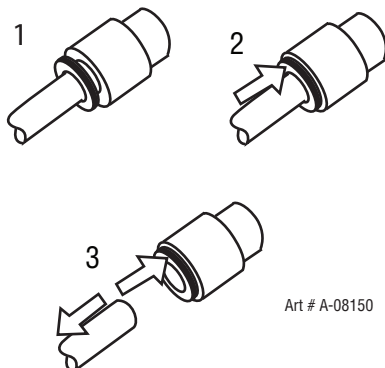

3. Pull the hose from the fitting.
4. Replace the hose by pushing the hose back into the fitting until it fully seats. Check it by pulling on the hose. If done correctly it will not pull out.
5. Reinstall the power supply cover

D. Air Regulator Replacement

Tools required: T20 Torx Driver, 11/16" Open End Wrench

1. Remove the cover per subsection 7.04A
2. Remove the two(2) air hoses from the regulator per subsection 7.05-C
3. Disconnect cable from the Pressure Transducer
4. Pull the Air Regulator adjusting knob from the shaft.
5. Loosen and remove the locking nut securing the Air Regulator to the front Panel, then remove the regulator.
6. Remove the Pressure Transducer from the regulator and install on new regulator using liquid pipe thread sealant.
6. Install replacement Air Regulator by reversing the above steps 2-5.
7. Reinstall the power supply cover

E. Pressure Transducer Replacement

Tools required: T20 Torx Driver, 11/16" Open End Wrench

1. Remove Air Regulator per subsection 7.05D
2. Remove the defective Pressure Transducer from the regulator and install the new Transducer onto the Air Regulator.
3. Install the regulator assembly per subsection 7.05D.
4. Reinstall the power supply cover

F. Gas Solenoid Replacement

Tools required: T20 Torx Driver, Flat Screw Driver

1. Remove the cover per subsection 7:04A
2. Disconnect J5 connector from the Main PCB.
3. Remove the air hose from Gas Solenoid per subsection 7.05-C
4. The Solenoid utilizes the same type locking fitting as the gas hoses. Using a flat blade screw driver, push the locking ring towards the Solenoid while pulling the Solenoid away from the ATC.
5. Install the replacement Gas Solenoid by reversing the above steps
6. Reinstall the power supply cover

G. Logic PCB (PCB3) Replacement

Tools required: T20 Torx Driver Flat Screw Driver, ½" wrench

1. Remove the cover per subsection 7.04A
2. Remove the two large and one small gas hoses from the pressure regulator per subsection 7.05C.
3. Unplug the connector J2 from the Main PCB.
4. Disconnect cable from the Pressure Transducer
5. Disconnect front panel from base per subsection 7.04D
6. Remove the Current Control Potentiometer Knob and nut securing the potentiometer shaft to the front panel per subsection 7.05A
7. Remove the Function Control Switch Knob and the nut securing the switch shaft to the front panel per subsection 7.05B.
8. Install the replacement Logic PCB by reversing the above steps.
9. Reinstall the power supply cover.

H. ON/OFF Switch (SW1) Replacement

Tools required: T20 Torx Driver

1. Remove the cover per subsection 7.04A
2. Disconnect the wires on the rear of the switch, noting the location and orientation of each wire as shown below.

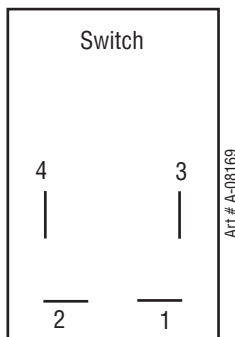

3. Squeeze together the clips on the back of the switch, then remove the switch through the front panel.
4. Install the replacement switch by reversing the above steps.
5. Reinstall the power supply cover

I. Work Cable Replacement

Tools required: T20 Torx Driver

1. Remove the Cover per subsection 7.04A.
2. Disconnect the work cable from the WORK1 terminal on the Main PCB.
3. Squeeze the top and bottom of the Work Cable Strain Relief and remove from the front panel.
4. Install the replacement Work Cable by reversing the above steps.
5. Reinstall the power supply cover

7.06 Left Side Internal Parts Replacement

A. Fan Replacement

Tools required: T20 Torx Driver

Fan MOT1

1. Remove the Cover per subsection 7.04A
2. Unplug J7 connector from Main PCB
3. Carefully feed the fan wires through the center chassis wire slot.
4. Remove the fan by pushing the fan retaining clips apart and pulling the fan out of the center chassis.
5. On the replacement fan(s) note the direction of air flow as labeled on the fan housing and orient so fan will blow air into the heatsink.
6. Install replacement fan by reversing the above steps.
7. Reinstall the power supply cover

Fans MOT2 or MOT3

1. Remove the Cover per subsection 7.04A
2. Unplug corresponding J1 or J2 connector from the Main PCB.
3. Carefully feed the fan wires through the center chassis wire slot.
4. Remove the fan by pushing the fan retaining clips apart and pulling the fan out of the center chassis.
5. On the replacement fan(s) note the direction of air flow as labeled on the fan housing and orient so fan will blow air into the heatsink.
6. Install replacement fan by reversing the above steps.
7. Reinstall the power supply cover

B. Main Transformer (T1) Replacement

Tools required: T20 Torx Driver

1. Remove the Cover per subsection 7.04A
2. Remove the two large and one small gas hoses per subsection 7.05C
3. Remove the Gas Solenoid per subsection 7.05F
4. Disconnect the transformer wires from terminals PRI 1 (A), PRI 2 (B) from the Capacitor PCB and PRI 3 (D), PRI 4 (C), SEC1, SEC2 on the Main PCB.
5. Disconnect J2 & J3 connectors from Main PCB.
6. Remove the two screws securing the Center Chassis to the base.
7. Loosen the two screws securing the W1 contactor to the base. Move the contactor out for clearance for the Center Chassis.
8. Disengage the Front and Rear panels from the base per section 7.04D.
9. Guide the Center Chassis towards the center of the base to disengage the bottom locking tabs securing the Chassis to the base.
10. Carefully guide the Center Chassis up far enough to lay the Chassis down to the right side of the unit.
11. Remove the two screws securing the Main Transformer to the base.
12. Remove the Main Transformer, carefully guiding all its wires through from the right side of the unit.
13. Install replacement Transformer by reversing the above steps.
14. Reinstall the power supply cover

C. Main Transformer (T2) Replacement

Tools required: T20 Torx Driver

1. Remove the Cover per subsection 7.04A
2. Remove the two large and one small gas hoses per subsection 7.05C
3. Remove the Gas Solenoid per subsection 7.05F
4. Disconnect the transformer wires from terminals PRI 1 (A), PRI 2 (B), PRI 3 (D), PRI 4 (C), SEC1, SEC2 on the 40A Power PCB.
5. Disconnect J2 & J3 connectors from Main PCB.
6. Remove the two screws securing the Center Chassis to the base.

7. Loosen the two screws securing the W1 contactor to the base. Move the contactor out for clearance for the Center Chassis..
8. Disengage the Front and Rear panel from the base per section 7.04D.
9. Guide the Center Chassis towards the center of the base to disengage the bottom locking tabs securing the Chassis to the base.
10. Carefully guide the Center Chassis up far enough to lay the Chassis down to the right side of the unit.
11. Remove the two screws securing the Main Transformer to the base.
12. Remove the Main Transformer, carefully guiding all its wires through from the right side of the unit.
13. Install replacement Transformer by reversing the above steps.
14. Reinstall the power supply cover

D. Output Inductor (L1)

Tools required: T20 Torx Driver

1. Remove the Cover per subsection 7.04A
2. Remove the two large and one small gas hoses per subsection 7.05-C
3. Remove the Gas Solenoid per subsection 7.05F
4. Disconnect Output Inductor wires from Choke1 terminal on the Main PCB and from the ATC.
5. Disconnect J2 & J3 connectors from Main PCB.
6. Remove the two screws securing the Center Chassis to the base.
7. Loosen the two screws securing the W1 contactor to the base. Move the contactor out for clearance for the Center Chassis.
8. Disengage the Front and Rear panel from the base per section 7.04D.
9. Carefully guide the Center Chassis towards the center of the base to disengage the bottom locking tabs securing the Chassis to the base.
10. Carefully guide the Center Chassis up far enough to lay the Chassis down towards the right side of the unit.
11. Remove the two screws securing the Output Inductor to the base.
12. Remove the Output Inductor, carefully guiding its wires through from the right side of the unit.

13. Install replacement Output Inductor by reversing the above steps.
14. Reinstall the power supply cover.

E. Output Inductor (L2)

Tools required: T20 Torx Driver

1. Remove the Cover per subsection 7.04A
2. Remove the two large and one small gas hoses per subsection 7.05-C
3. Remove the Gas Solenoid per subsection 7.05F
4. Disconnect Output Inductor wires from Choke1 terminal on the 40A Power PCB and from the ATC.
5. Disconnect J2 & J3 connectors from Main PCB.
6. Remove the two screws securing the Center Chassis to the base.
7. Loosen the two screws securing the W1 contactor to the base. Move the contactor out for clearance for the Center Chassis.
8. Disengage the Front and Rear panel from the base per section 7.04D.
9. Carefully guide the Center Chassis towards the center of the base to disengage the bottom locking tabs securing the Chassis to the base.
10. Carefully guide the Center Chassis up far enough to lay the Chassis down towards the right side of the unit.
11. Remove the two screws securing the Output Inductor to the base.
12. Remove the Output Inductor, carefully guiding its wires through from the right side of the unit.
13. Install replacement Output Inductor by reversing the above steps.
14. Reinstall the power supply cover.

7.07 Rear Panel Parts Replacement

A. Filter Element Assembly Replacement

The Filter Element Assembly is in the rear panel. For better system performance, the filter element should be checked per the Maintenance Schedule (Subsection 5.02), and either cleaned or replaced.

1. Remove power from the power supply; turn off the gas supply and bleed down the system.
2. Remove the system cover. See "A Cover Removal" in 7.04 section.
3. Locate the internal air line and the fitting from the filter assembly. Number 1 in the following illustration.
4. Hold a wrench or similar tool against the locking ring on the filter assembly fitting, then pull on the hose to release it. (Numbers 2 and 3 in the following illustration).

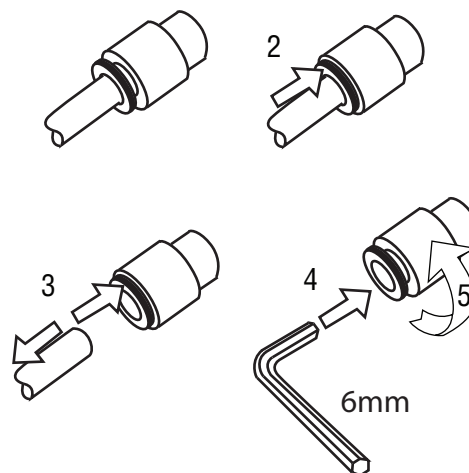
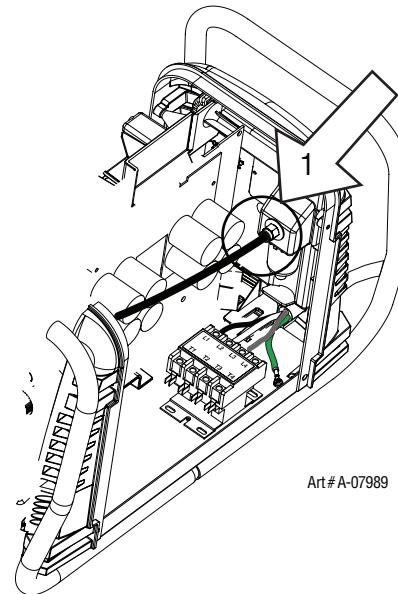

5. Remove the fitting from the filter element assembly by inserting a 6 mm hex wrench into the internal hex fitting and turning it counter clock-wise (left). Numbers 4 and 5 in the previous illustration.
6. Disconnect the input line from the filter element assembly.
7. Remove the filter element assembly through the rear opening.

NOTE

If replacing or cleaning just the filter element refer to the following illustration for disassembly.

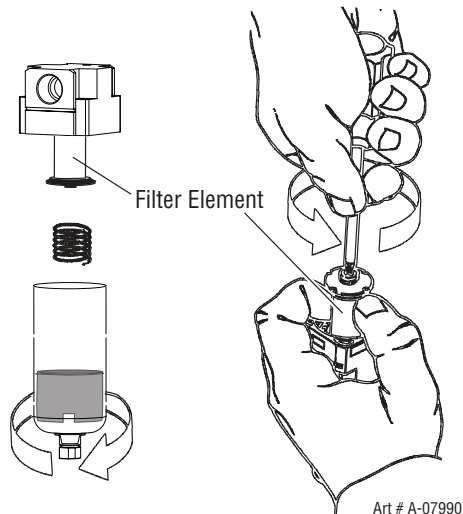

8. Install the new or cleaned assembly by reversing these procedures.
9. Turn on the air supply and check for leaks before reinstalling the cover.

B. Input Power Cable Replacement

Tools required: Phillips Head Screwdriver, Flathead Screwdriver,

1. Remove the Cover per subsection 7.04A
2. Disconnect the input cable wires from the W1 contactor terminals and ground lug.
(For CE units: Disconnect input cable from the CE Input Power Filter terminals and ground lug.)
3. Loosen the two screws in the cable strain relief
4. Remove cable through the rear panel.
5. Install replacement Input Power Cable by reversing above steps.
6. Reinstall the power supply cover

D. Optional Single-Stage Filter Element Replacement

These instructions apply to power supplies where the optional Single-Stage Filter has been installed.

The Power Supply shuts down automatically when the Filter Element becomes completely saturated. The Filter Element can be removed from its housing, dried, and reused. Allow 24 hours for Element to dry. Refer to Section 6, Parts List, for replacement filter element catalog number.

1. Remove power from power supply.
2. Shut off air supply and bleed down system before disassembling Filter to change Filter Element.
3. Disconnect gas supply hose.
4. Turn the Filter Housing Cover counter-clockwise and remove it. The Filter Element is located inside the Housing.

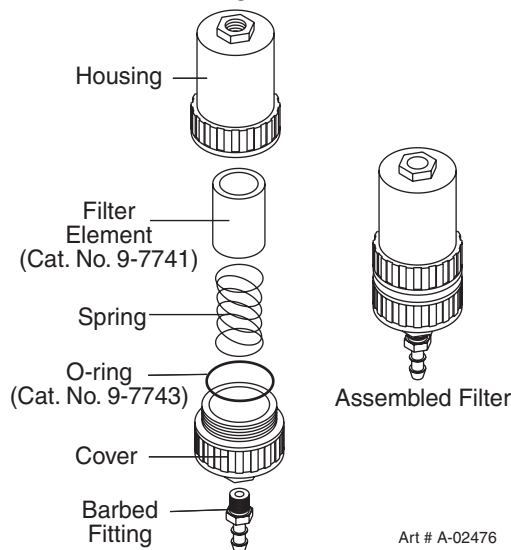

Optional Single-Stage Filter Element Replacement

5. Remove the Filter Element from the Housing and set Element aside to dry.
6. Wipe inside of housing clean, then insert the replacement Filter Element open side first.
7. Replace Housing on Cover.
8. Reattach gas supply.
9. Reinstall the power supply cover

NOTE

If unit leaks between housing and cover, inspect the "O" Ring for cuts or other damage.

CUTMASTER 40mm

Optional Two-Stage Filter Element Replacement

The Two-Stage Air Filter has two Filter Elements. When the Filter Elements become dirty the Power Supply will continue to operate but cut quality may become unacceptable. Refer to Section 6, Parts List, for replacement filter element catalog number.

1. Shut off primary input power.
2. Shut off air supply and bleed down system.



WARNING

Always turn off the air supply and bleed the system before disassembling the Filter Assembly as injury could result.

3. Loosen the two bolts on the top of the Filter Assembly enough to allow the Filter Elements to move freely.
4. Note the location and orientation of the old Filter Elements.
5. Slide out the old Filter Elements.

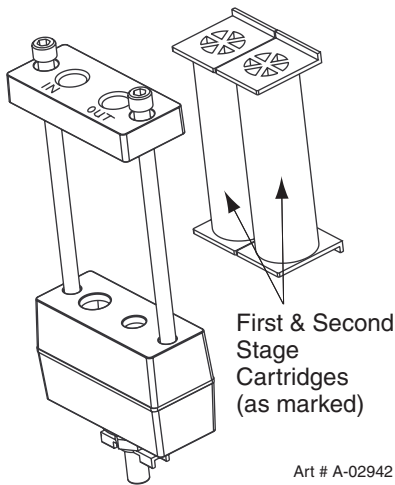

Optional Two-Stage Filter Replacement

6. Slide the replacement Filter Elements into the Filter Assembly, with the same orientation as noted in Step 4 above.
7. Hand tighten the two bolts evenly, then torque each bolt to 20 - 30 in-lbs (2.3 - 3.4 Nm). Improper torque may damage the gasket.
8. Slowly apply air pressure to the assembly, checking for leaks.

NOTE

A small amount of air leakage from the bottom fitting is normal.

This completes the parts replacement procedures.

7.08 Right Side Internal Parts Replacement

A. Capacitor PCB (PCB2) Replacement

Tools required: T20 Torx Driver, #2 Phillips Head Driver

1. Remove the Cover per subsection 7.04A
2. Disconnect J1 & J2 from PCB2.
3. Note the location and remove all wires connected to PCB2
4. Remove the fifteen (15) screws securing PCB2 to the Main PCB and 40AMP PCB
5. Install the replacement PCB by reversing the above steps.

B. Main PCB (PCB1) Replacement

Tools required: T20 Torx Driver

1. Remove the Cover per subsection 7.04A
2. Remove Capacitor PCB per subsection 7.08A
3. Remove the two large gas hoses per subsection 7.05-C
4. Remove the Gas Solenoid per subsection 5.05F
5. Disconnect the wires and connectors from the PCB, noting the location and orientation of each wire and connector.
6. Remove the four (4) mounting screws securing the PCB to the center chassis.
7. Carefully guide the PCB assembly up and out of the unit.
8. Install the replacement PCB by reversing the above steps.
9. Reinstall the power supply cover

C. Main Contactor (W1) Replacement

Tools required: T20 Torx Driver

1. Remove the Cover per subsection 7.04A
2. Remove all wires from W1, noting the location and orientation of each wire
3. Loosen the two (2) Torx head screws securing the Main Contactor to the base.
4. Slide the contactor towards the rear of the unit slightly to allow the contactor to clear the mounting screws.
5. Lift Main Contactor up and out of the unit.
6. Install the replacement Contactor by reversing the above steps.
- 7 Reinstall the power supply cover.

D. 40 AMP PCB (PCB5) Replacement

Tools required: T20 Torx Driver

1. Remove the Cover per subsection 7.04A
2. Remove Capacitor PCB per subsection 7.08A
3. Remove the two large gas hoses per subsection 7.05-C
4. Disconnect the wires and connectors from the PCB, noting the location and orientation of each wire and connector.
5. Remove the four (4) mounting screws securing the PCB to the center chassis.
6. Carefully guide the PCB assembly up and out of the unit.
7. Install the replacement PCB by reversing the above steps.
8. Reinstall the power supply cover

This Page Intentionally Blank

APPENDIX 1: SEQUENCE OF OPERATION (BLOCK DIAGRAM)

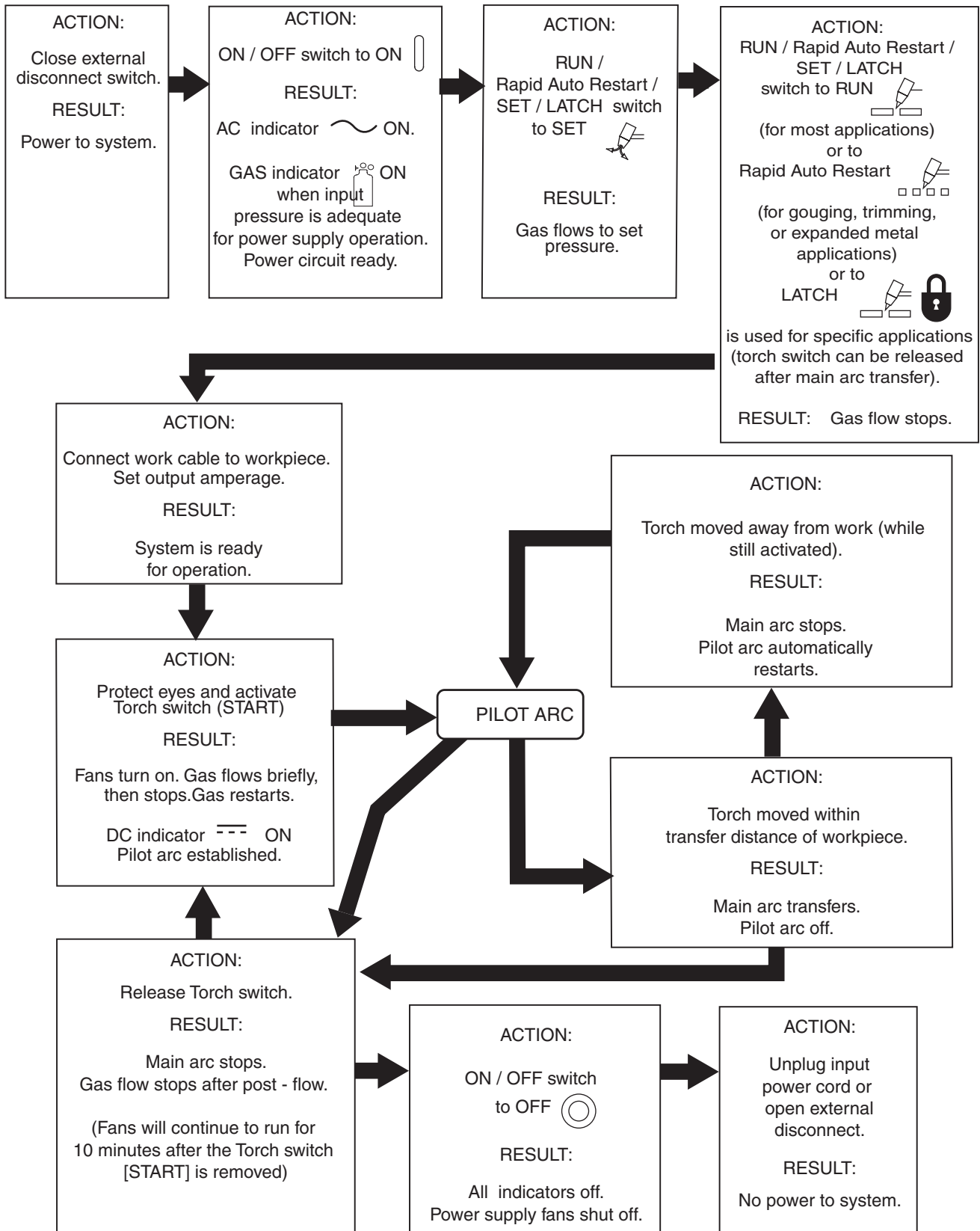

Art #A-08793

APPENDIX 2: DATA TAG INFORMATION

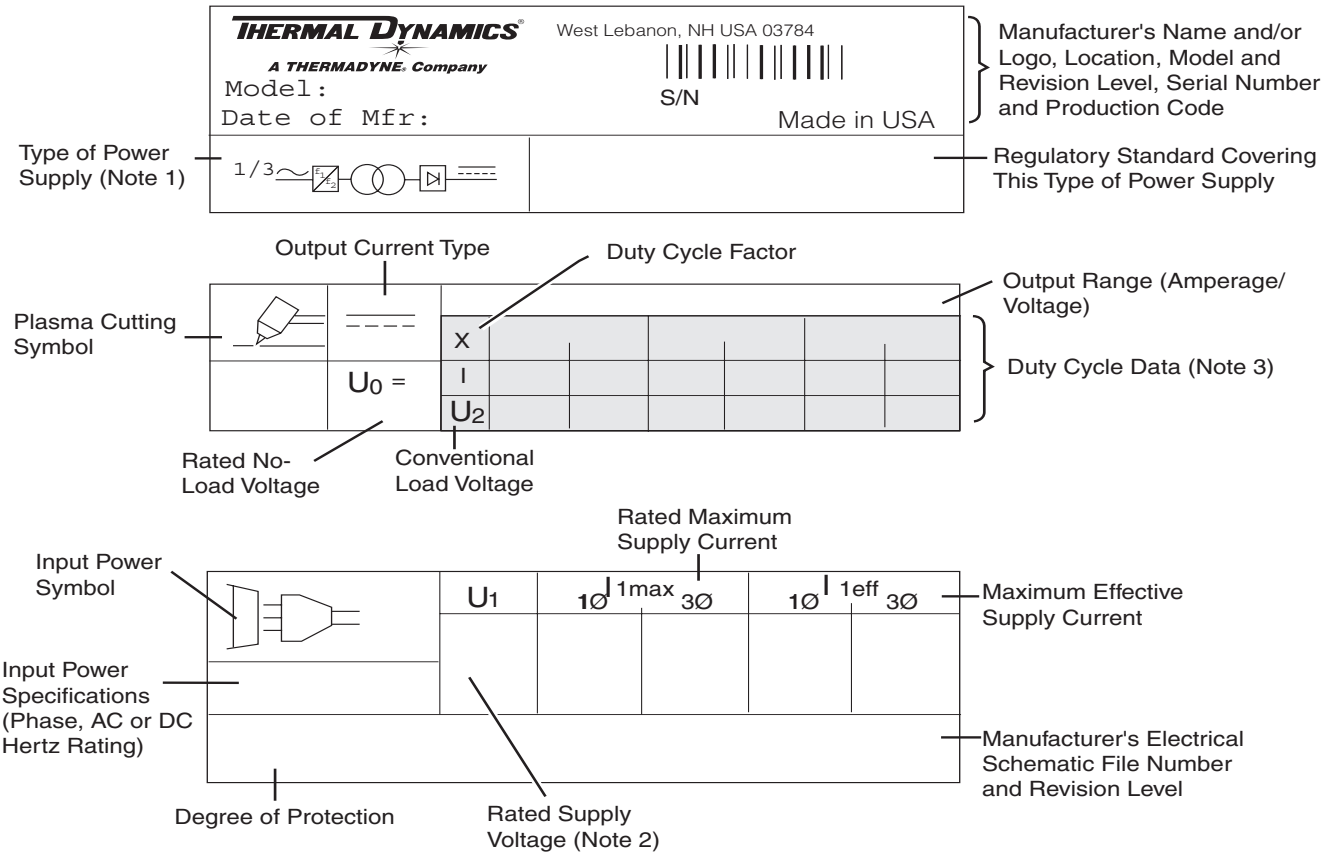

NOTES:

- Symbol shown indicates single- or three-phase AC input, static frequency converter-transformer-rectifier, DC output.
- Indicates input voltages for this power supply. Most power supplies carry a label at the input power cord showing input voltage requirements for the power supply as built.
- Top row: Duty cycle values.
IEC duty cycle value is calculated as specified by the International ElectroTechnical Commission.
TDC duty cycle value is determined under the power supply manufacturer's test procedures.
Second row: Rated cutting current values.
Third row: Conventional load voltage values.
- Sections of the Data Tag may be applied to separate areas of the power supply.

Standard Symbols

- ~ AC
- DC
- ∅ Phase

Art # A-03288

APPENDIX 3: TORCH PIN - OUT DIAGRAMS

A. Hand Torch Pin - Out Diagram

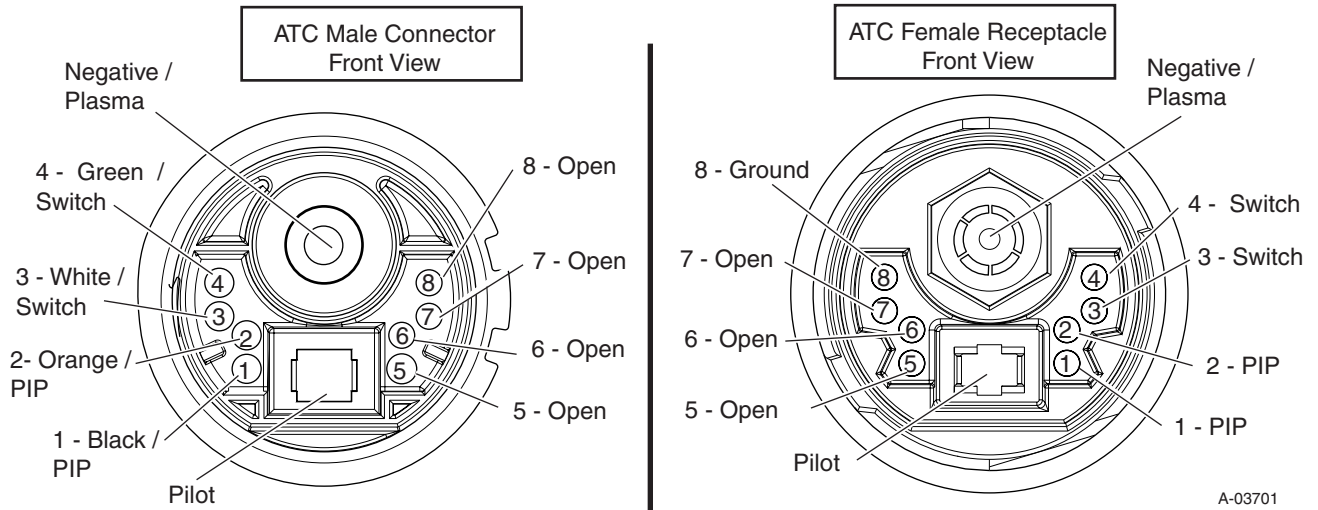

B. Mechanized (Machine) Torch Pin - Out Diagram

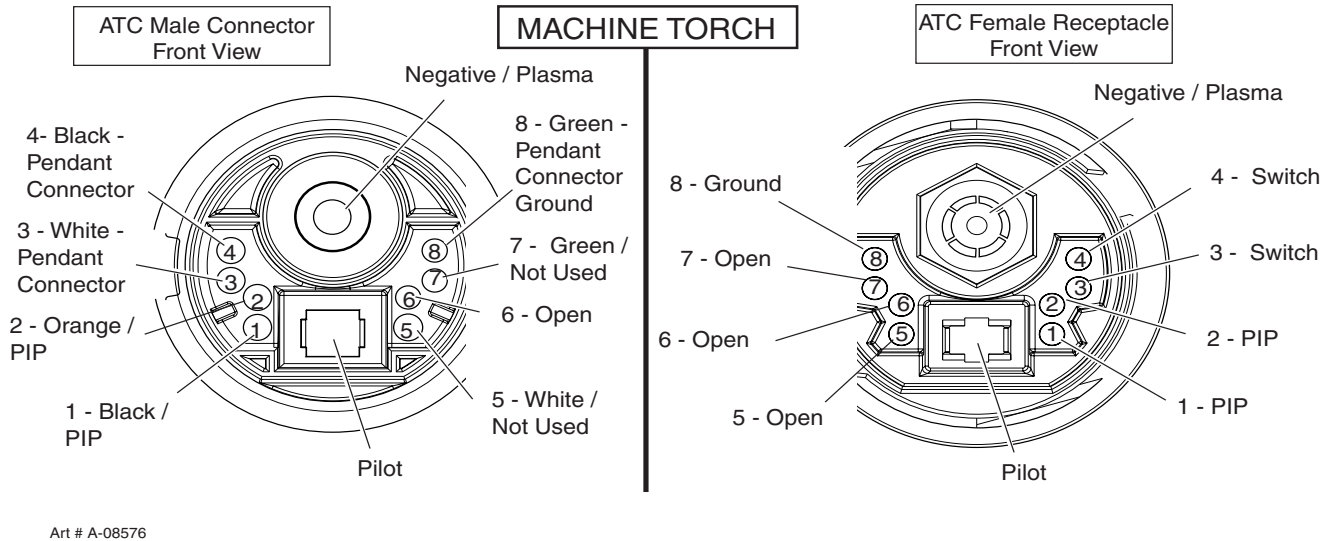

C. Automation (Machine) Torch Pin - Out Diagram

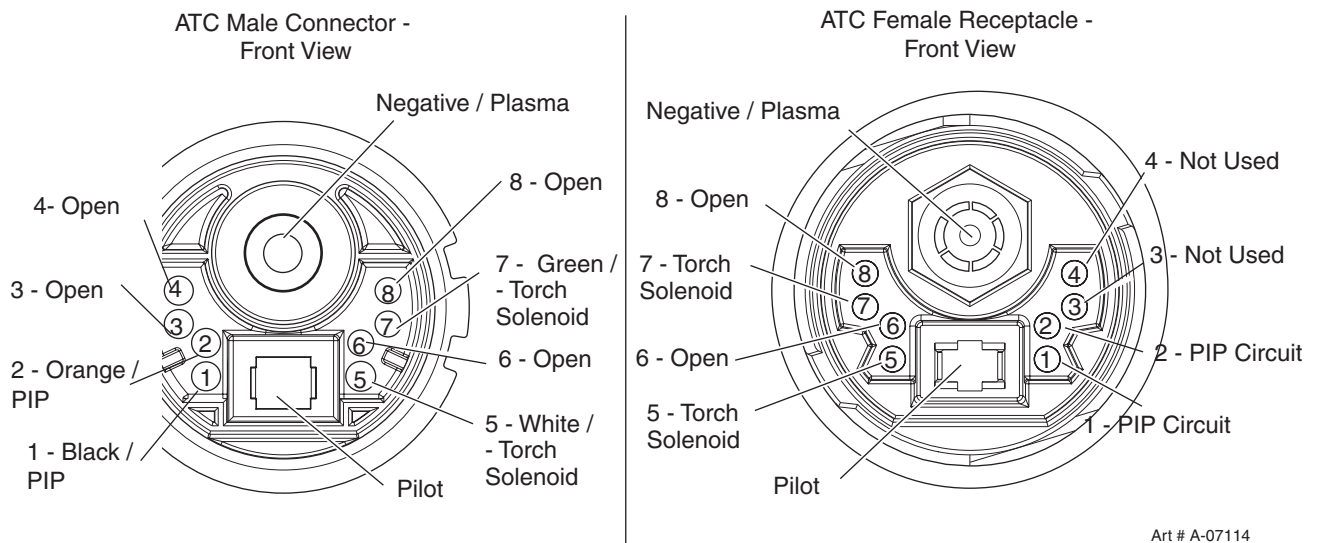

APPENDIX 4: TORCH CONNECTION DIAGRAMS

A. Hand Torch Connection Diagram

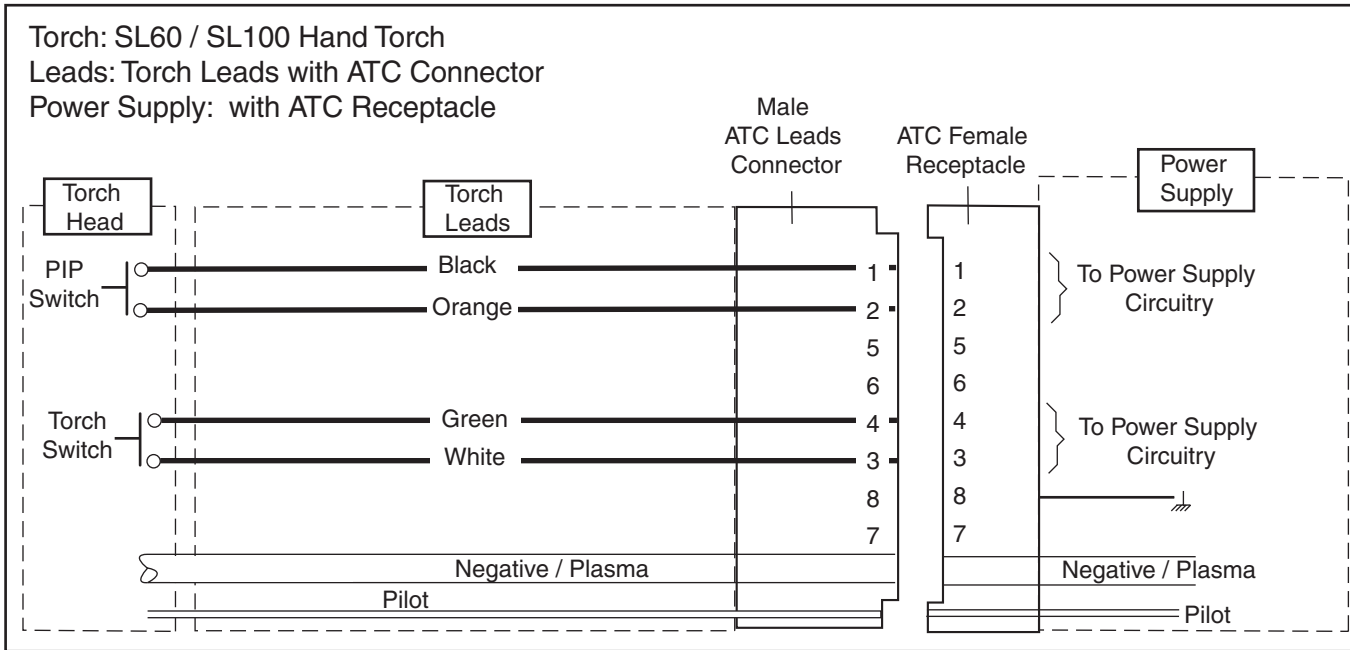

Art # A-03797

B. Mechanized Torch Connection Diagram

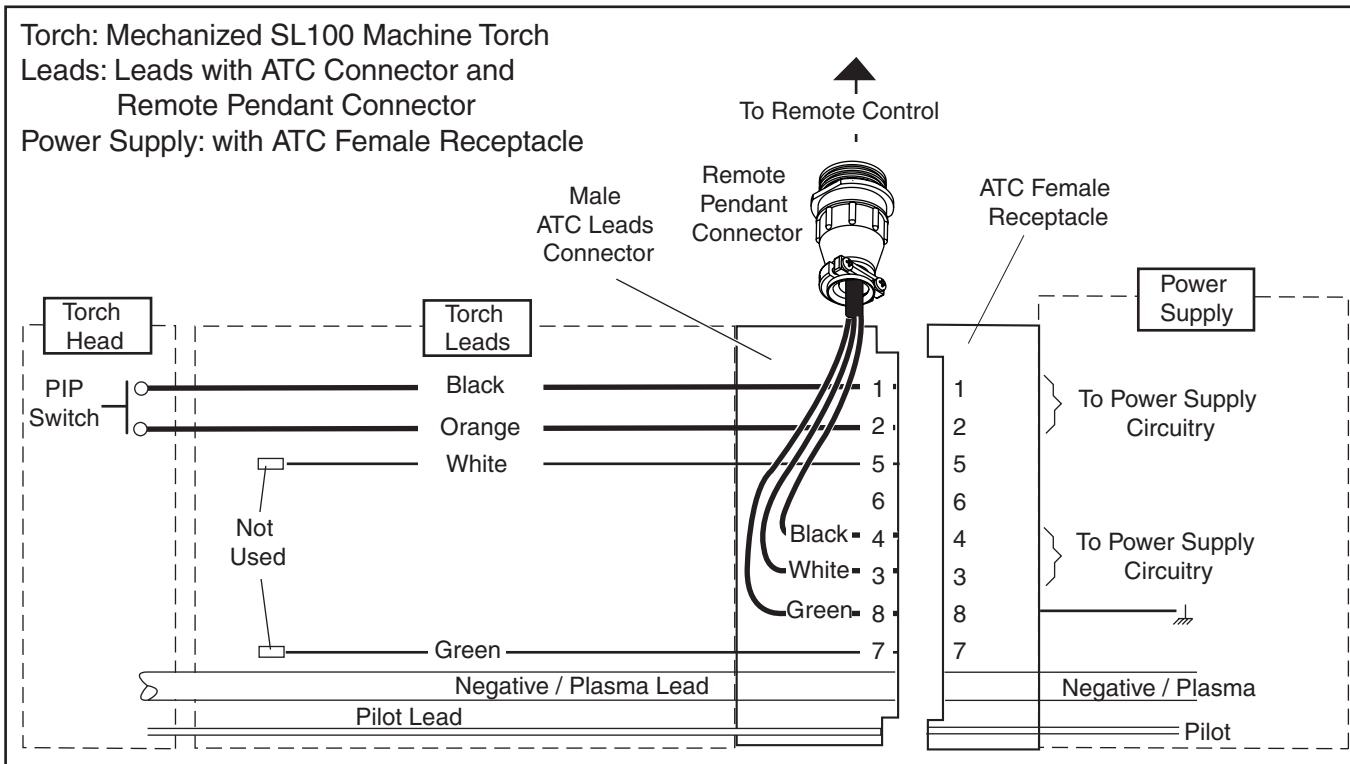

Art # A-08577

C. Automation Torch Connection Diagram

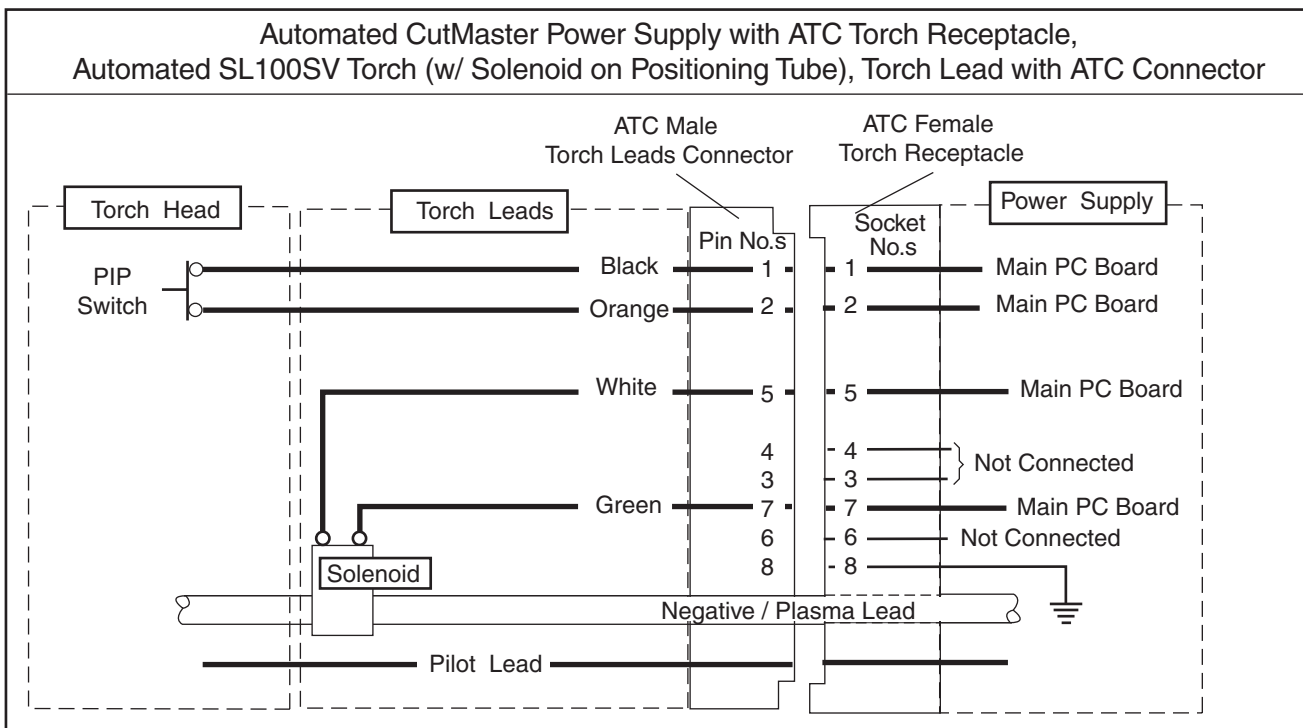

APPENDIX 5: SYSTEM SCHEMATIC, 380-415V UNITS

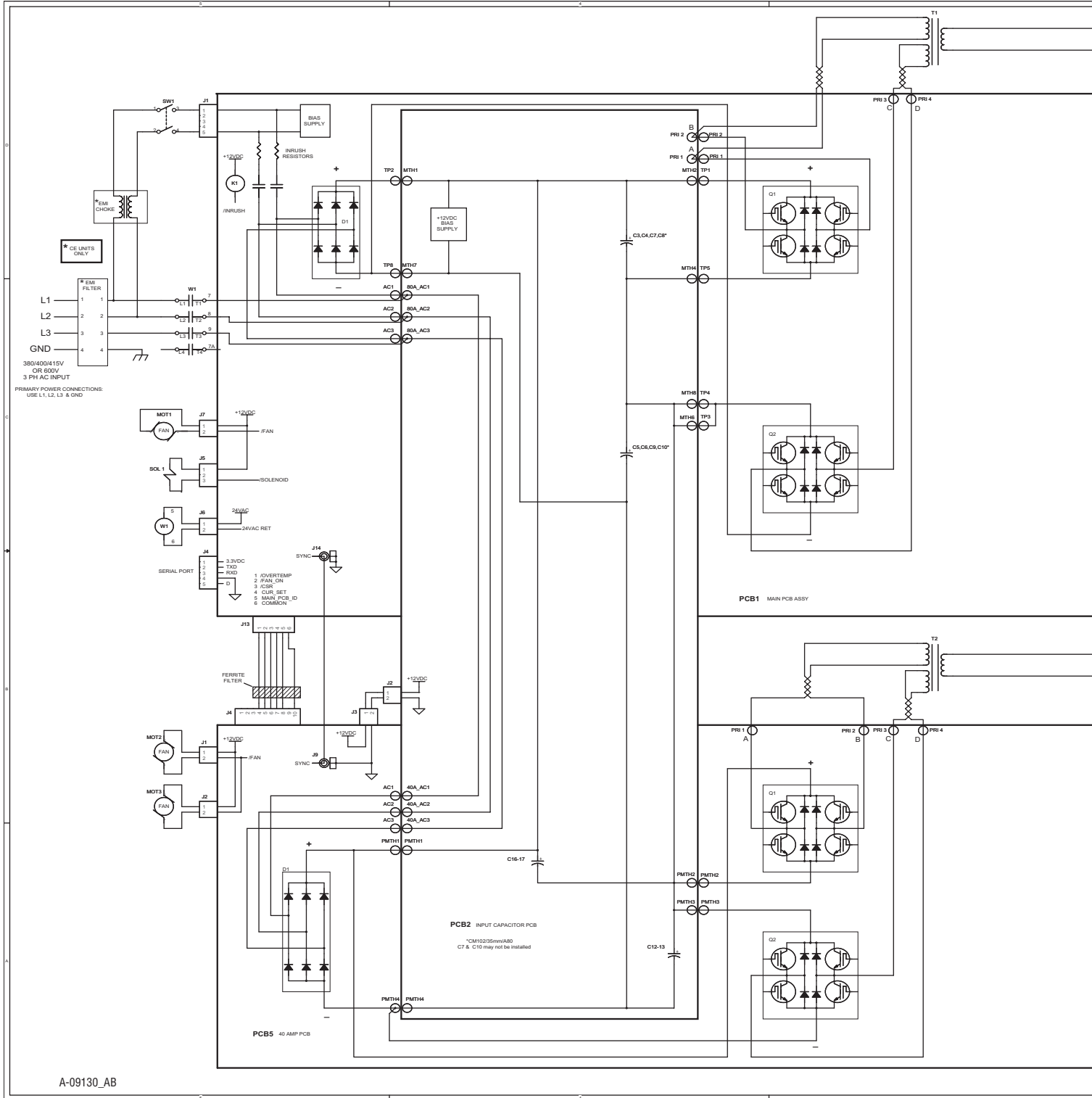

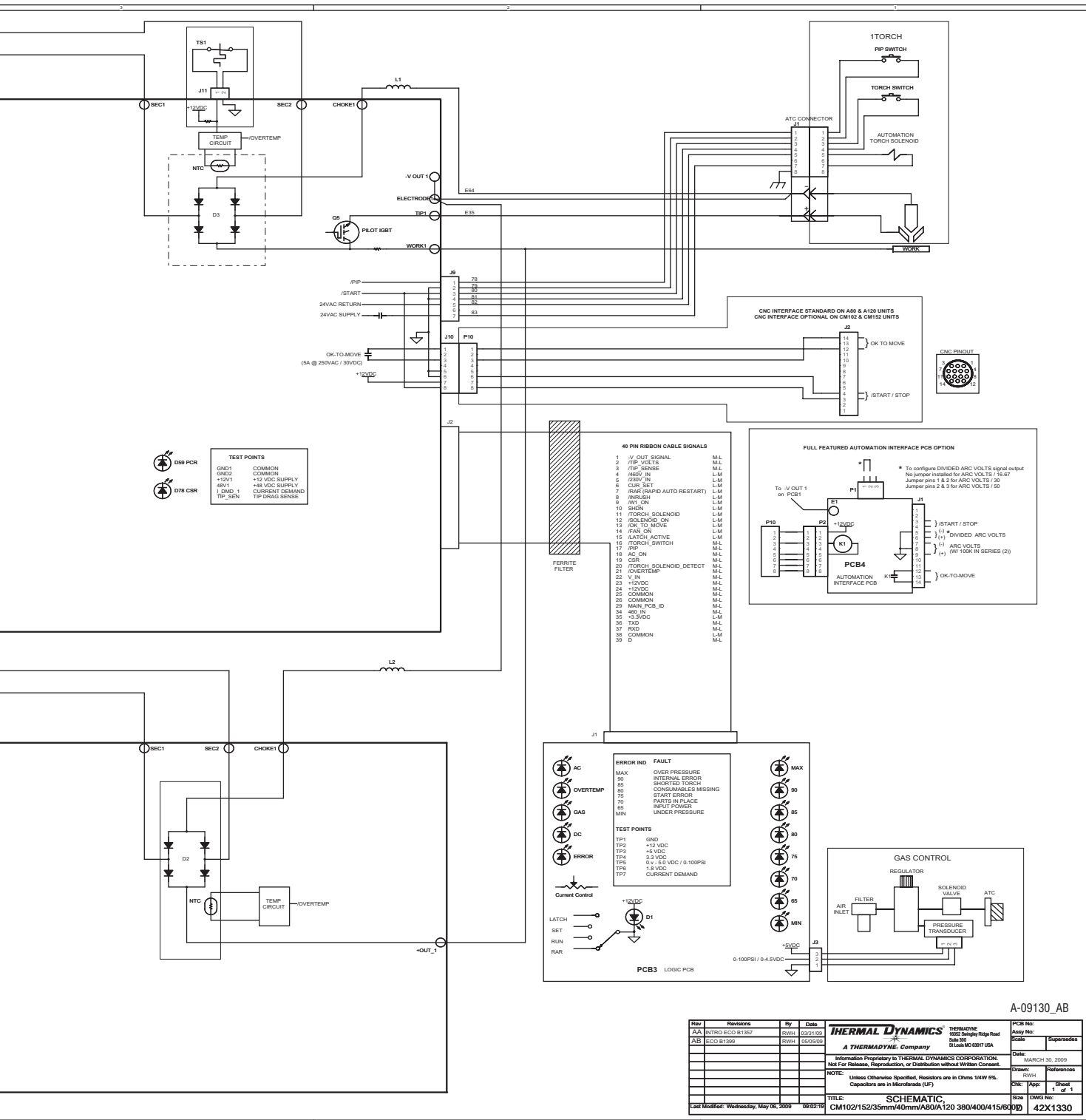

A-09130_AB

| Rev | Revisions | By | Date | PCB No: |
|-----|-----------------|-----|----------|------------|
| A.A | INTRO ECC 81557 | RWH | 03/31/03 | Asy No: |
| A.S | ECC 81559 | RWH | 05/05/03 | ECN |
| | | | | Supersedes |
| | | | | Date: |
| | | | | Drawn: |
| | | | | Chk: |
| | | | | Size |
| | | | | DWG No: |
| | | | | 42X1330 |

APPENDIX 6: Publication History

| Cover Date | Rev. | Change(s) |
|-------------------|-------------|---|
| Dec. 10, 2008 | AA | Manual released. |
| Dec. 23, 2008 | AB | Revised to correct Section 6 catalog numbers, Corrected Section 3 Art size, Added art for Logic PCB to section 5. |
| May 29, 2009 | AC | Updated 400V/600V schematic in appendix per ECOB1399. Corrected part numbers in section 6 per ECOB1201. |



GLOBAL CUSTOMER SERVICE CONTACT

Thermadyne USA

2800 Airport Road
Denton, Tx 76207 USA
Telephone: (940) 566-2000
800-426-1888
Fax: 800-535-0557

Thermadyne Canada

2070 Wyecroft Road
Oakville, Ontario
Canada, L6L5V6
Telephone: (905)-827-1111
Fax: 905-827-3648

Thermadyne Europe

Europe Building
Chorley North Industrial Park
Chorley, Lancashire
England, PR6 7Bx
Telephone: 44-1257-261755
Fax: 44-1257-224800

Thermadyne, China

RM 102A
685 Ding Xi Rd
Chang Ning District
Shanghai, PR, 200052
Telephone: 86-21-69171135
Fax: 86-21-69171139

Thermadyne Asia Sdn Bhd

Lot 151, Jalan Industri 3/5A
Rawang Integrated Industrial Park - Jln Batu Arang
48000 Rawang Selangor Darul Ehsan
West Malaysia
Telephone: 603+ 6092 2988
Fax : 603+ 6092 1085

Cigweld, Australia

71 Gower Street
Preston, Victoria
Australia, 3072
Telephone: 61-3-9474-7400
Fax: 61-3-9474-7510

Thermadyne Italy

OCIM, S.r.L.
Via Benaco, 3
20098 S. Giuliano
Milan, Italy
Tel: (39) 02-98 80320
Fax: (39) 02-98 281773

Thermadyne International

2070 Wyecroft Road
Oakville, Ontario
Canada, L6L5V6
Telephone: (905)-827-9777
Fax: 905-827-9797

Corporate Headquarters
16052 Swingley Ridge Road
Suite 300
St. Louis, MO 63017
Telephone: 636-728-3000
Email: TDCSales@Thermadyne.com
www.thermadyne.com

